

# Finite Automata

## Part Three

Recap from Last Time

# NFAs

- An **NFA** is a
  - **N**ondeterministic
  - **F**inite
  - **A**utomaton
- NFAs have no restrictions on how many transitions are allowed per state.
- They can also use  $\epsilon$ -transitions.
- An NFA accepts a string  $w$  if there is some sequence of choices that leads to an accepting state.

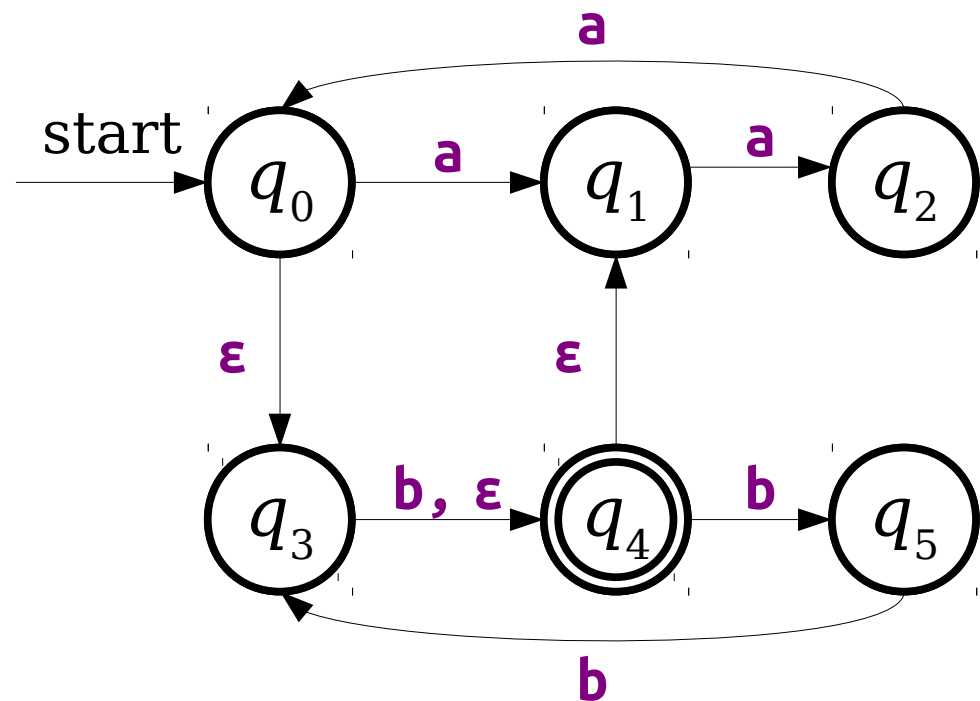

# Massive Parallelism

- An NFA can be thought of as a DFA that can be in many states at once.
- At each point in time, when the NFA needs to follow a transition, it tries all the options at the same time.
- The NFA accepts if *any* of the states that are active at the end are accepting states. It rejects otherwise.

New Stuff!

Just how powerful *are* NFAs?

# NFAs and DFAs

- Any language that can be accepted by a DFA can be accepted by an NFA.
- Why?
  - Every DFA essentially already *is* an NFA!
- **Question:** Can any language accepted by an NFA also be accepted by a DFA?
- Surprisingly, the answer is **yes!**

***Thought Experiment:***

How would you simulate a finite automaton  
in software?

# Tabular DFAs

# Tabular DFAs

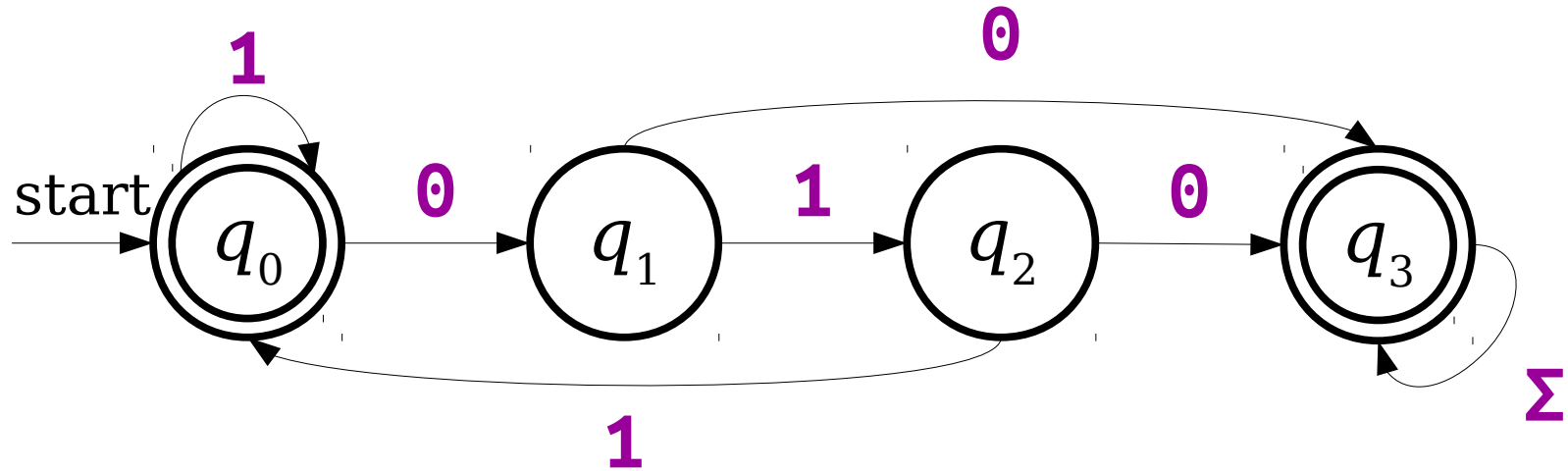

	0	1
$q_0$		
$q_1$		
$q_2$		
$q_3$		

# Tabular DFAs

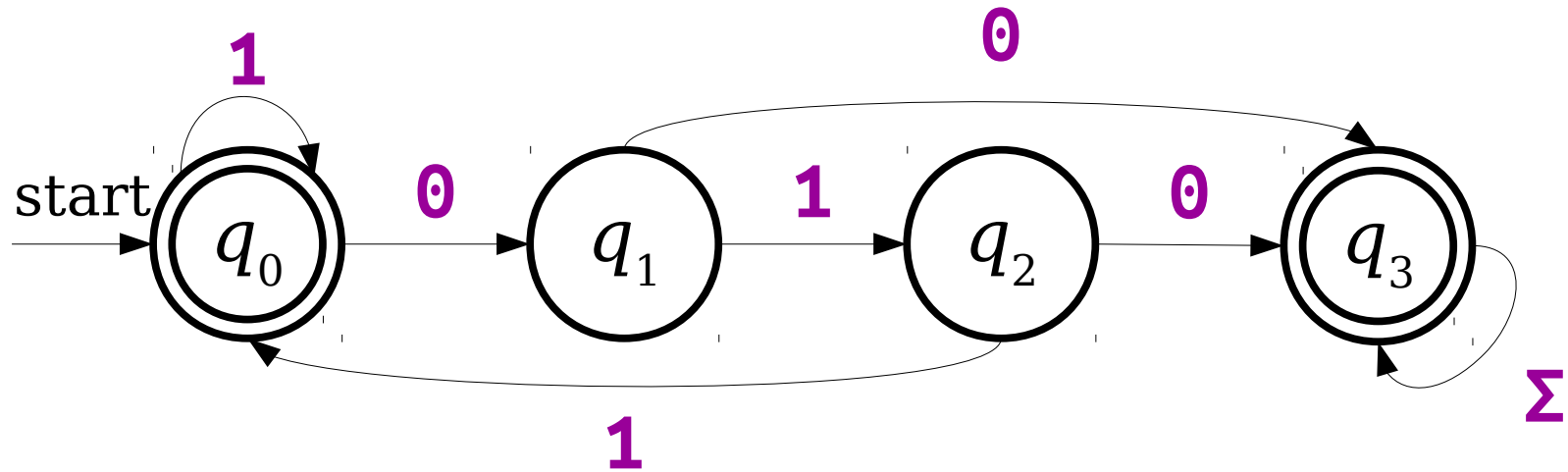

	0	1
$q_0$	$q_1$	$q_0$
$q_1$	$q_3$	$q_2$
$q_2$	$q_3$	$q_0$
$q_3$	$q_3$	$q_3$

# Tabular DFAs

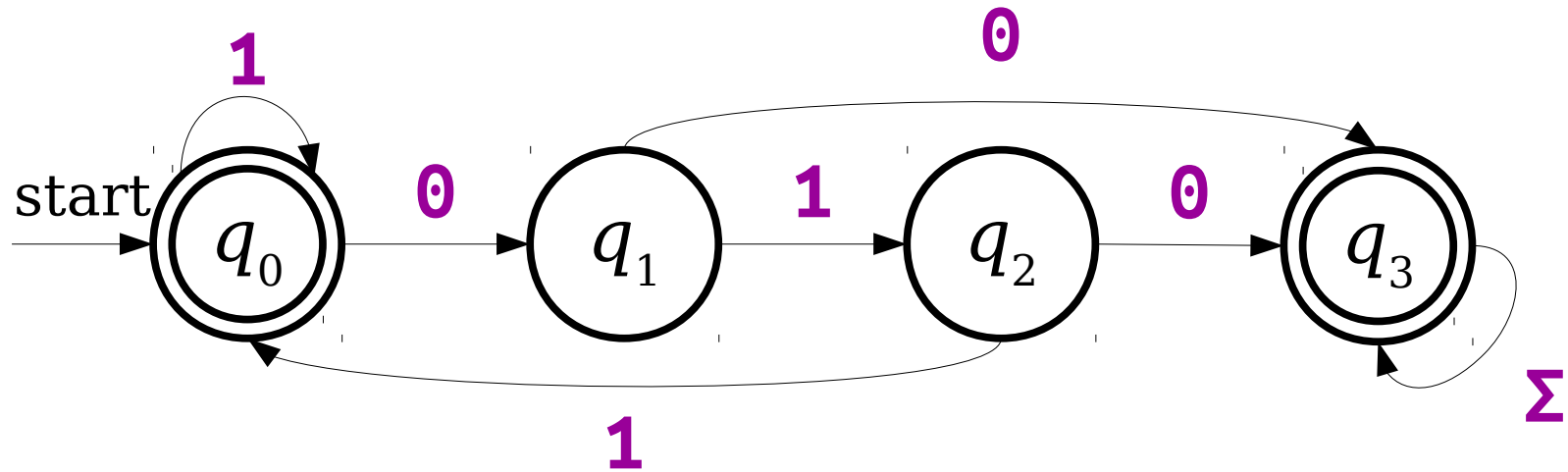

	0	1
* $q_0$	$q_1$	$q_0$
$q_1$	$q_3$	$q_2$
$q_2$	$q_3$	$q_0$
* $q_3$	$q_3$	$q_3$

# Tabular DFAs

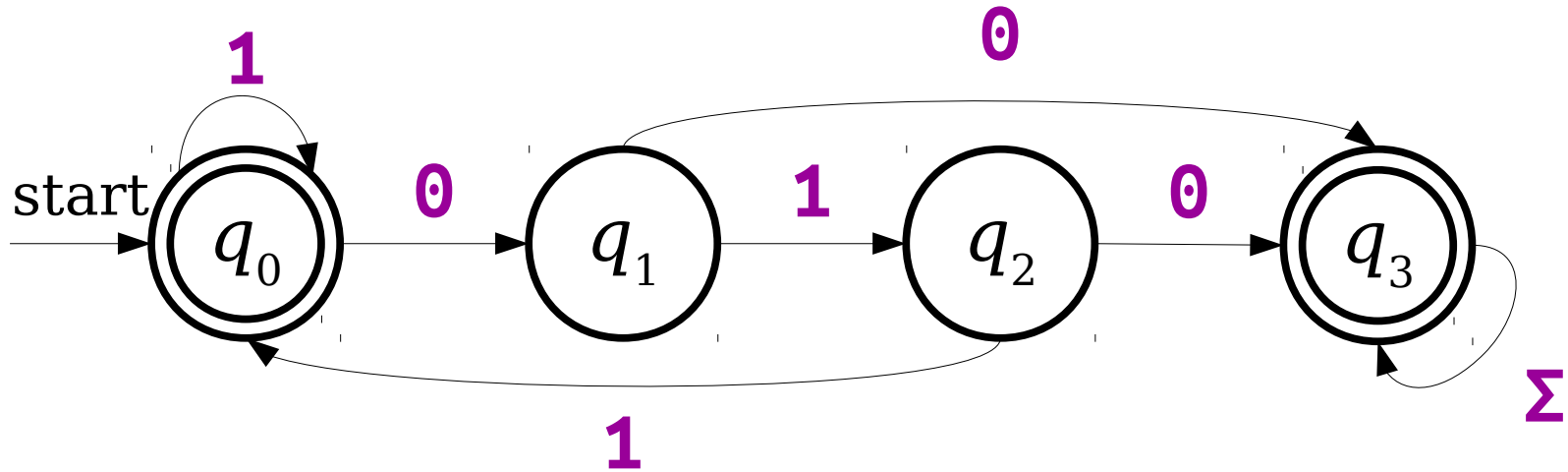

	0	1
* $q_0$	$q_1$	$q_0$
$q_1$	$q_3$	$q_2$
$q_2$	$q_3$	$q_0$
* $q_3$	$q_3$	$q_3$

These stars indicate accepting states.

# Tabular DFAs

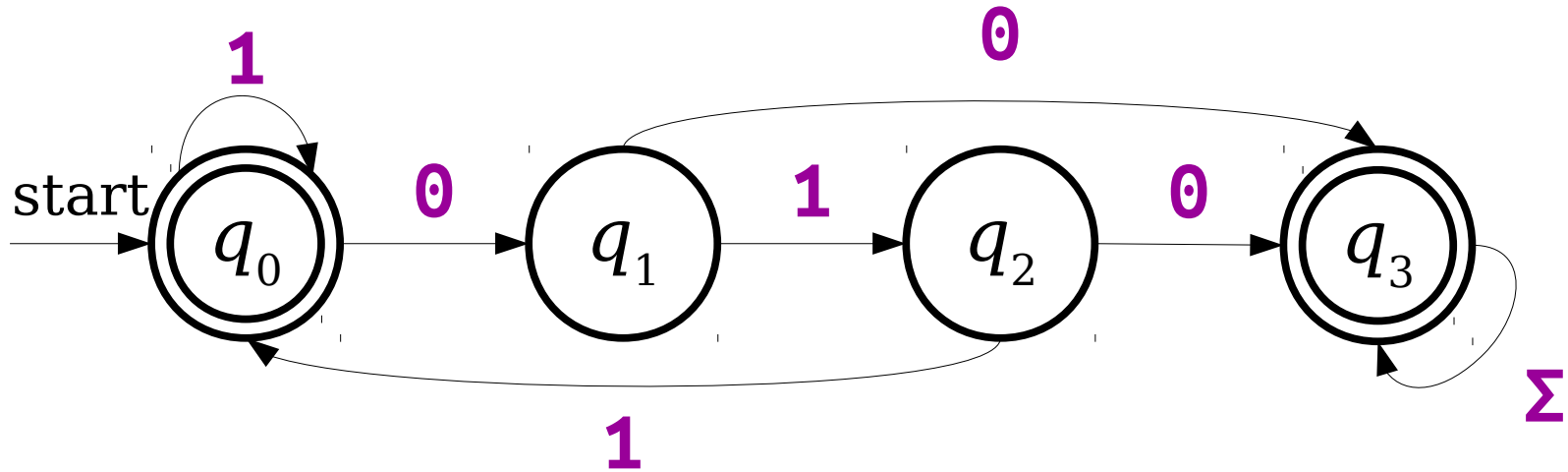

Since this is the first row, it's the start state.

	0	1
* $q_0$	$q_1$	$q_0$
$q_1$	$q_3$	$q_2$
$q_2$	$q_3$	$q_0$
* $q_3$	$q_3$	$q_3$

# Tabular DFAs

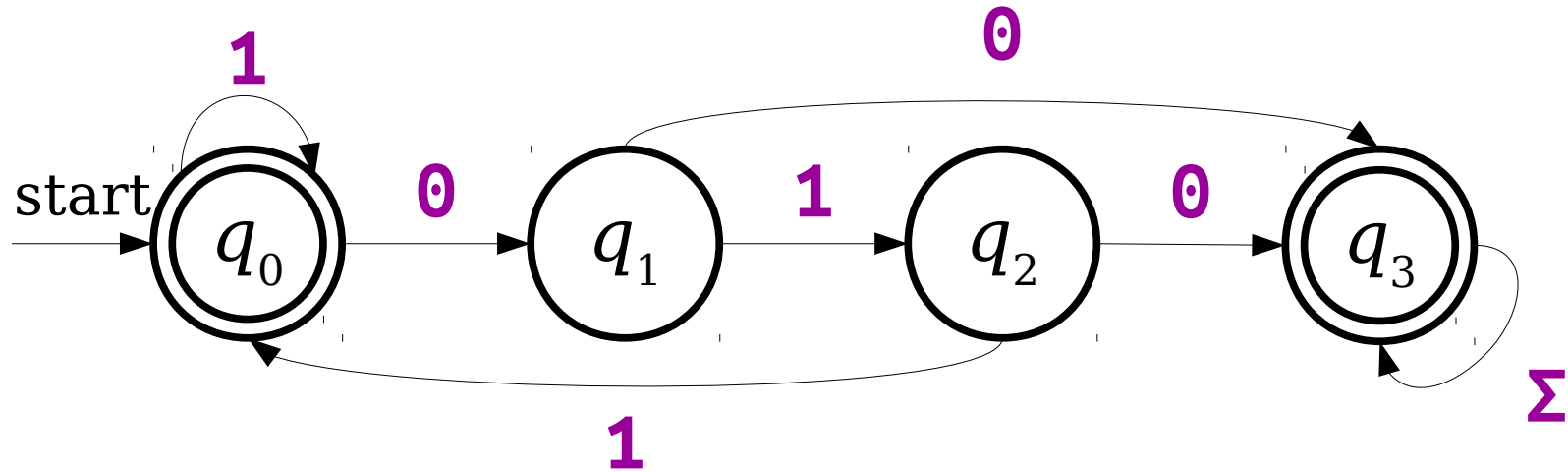

	0	1
* $q_0$	$q_1$	$q_0$
$q_1$	$q_3$	$q_2$
$q_2$	$q_3$	$q_0$
* $q_3$	$q_3$	$q_3$

Question to ponder: Why isn't there a column here for  $\Sigma$ ?

# My Turn to Code Things Up!

```
int kTransitionTable[kNumStates][kNumSymbols] = {
    {0, 0, 1, 3, 7, 1, ...},
    ...
};
bool kAcceptTable[kNumStates] = {
    false,
    true,
    true,
    ...
};
bool doesAccept(string input) {
    int state = 0;
    for (char ch: input) {
        state = kTransitionTable[state][ch];
    }
    return kAcceptTable[state];
}
```

Can we do something similar for NFAs?

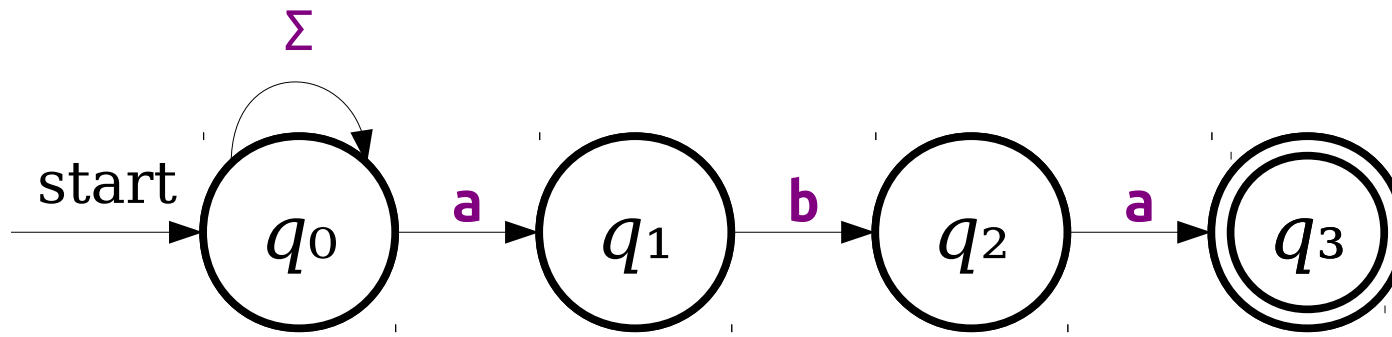

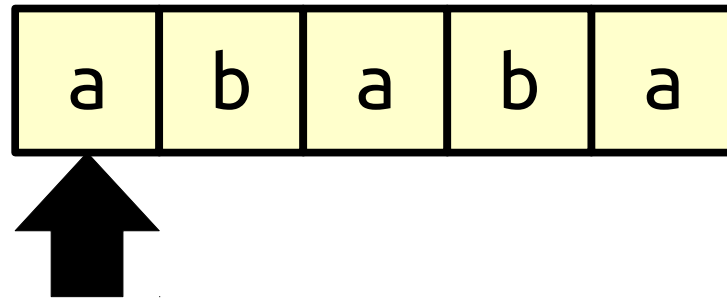
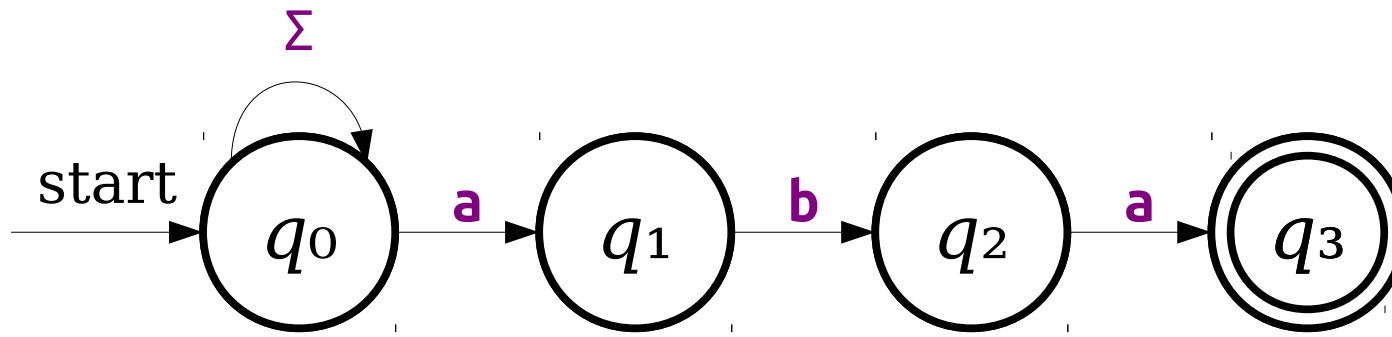

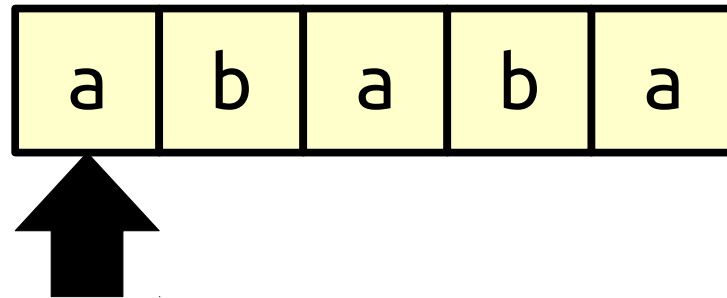
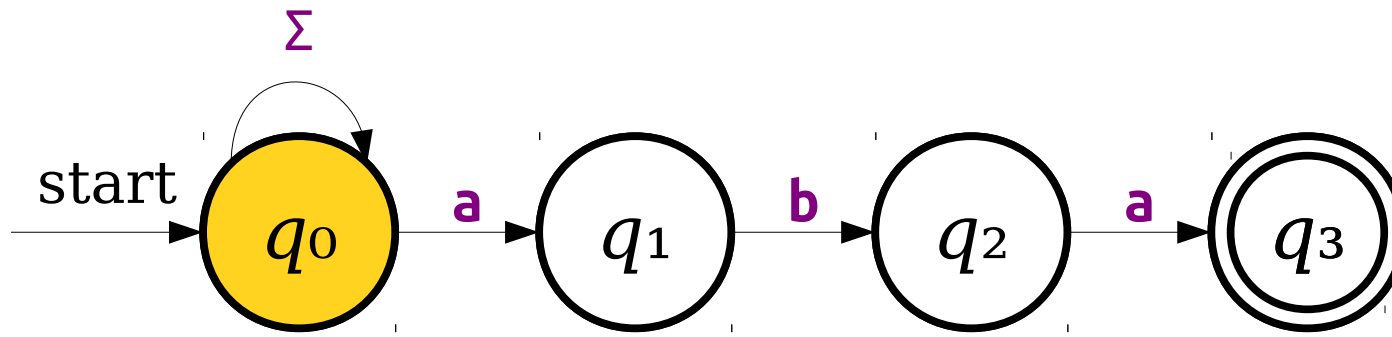

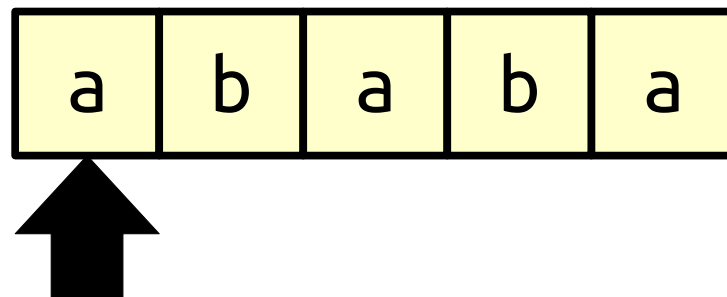
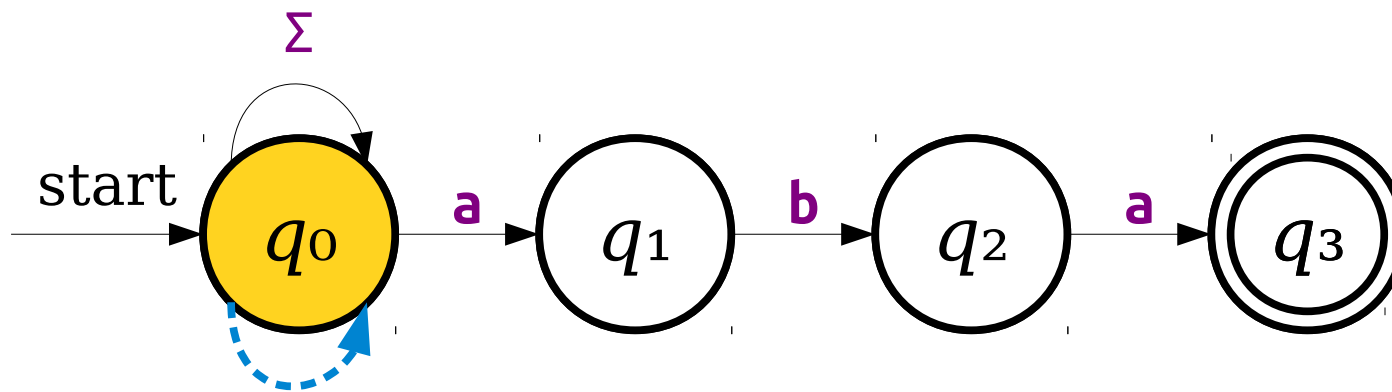

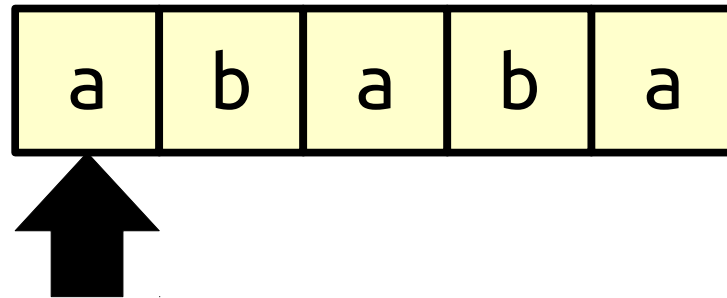
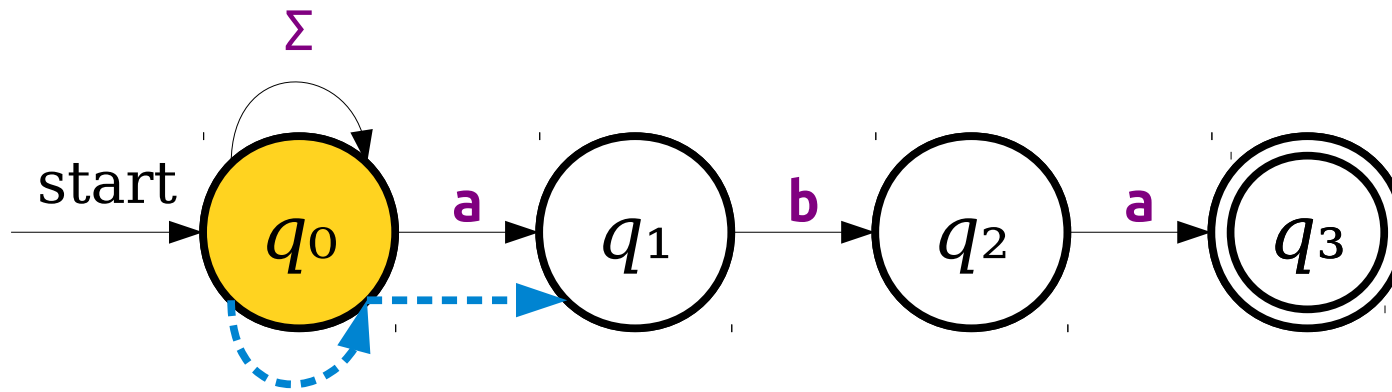

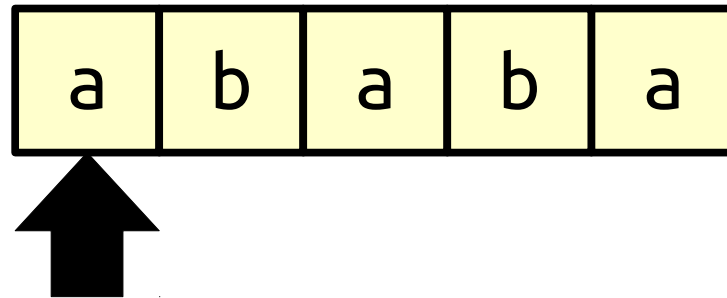
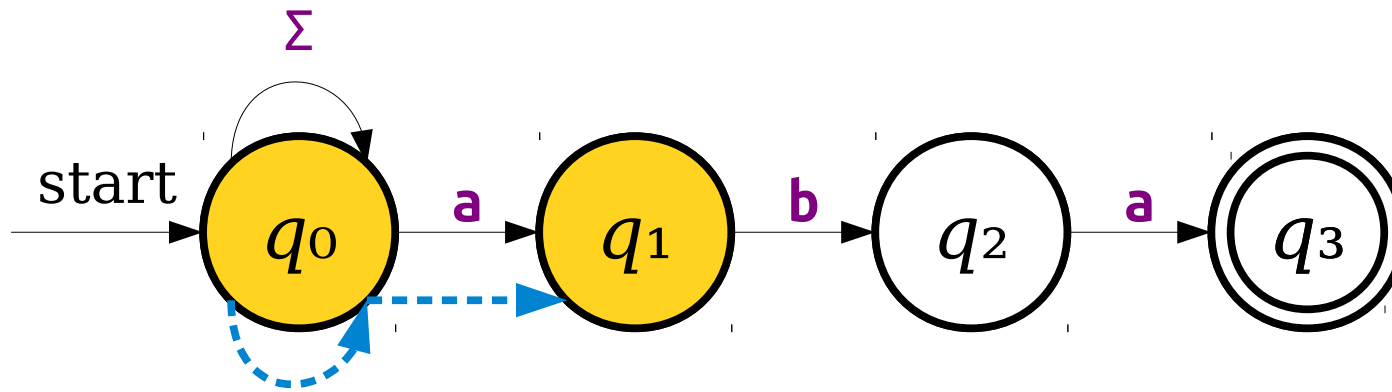

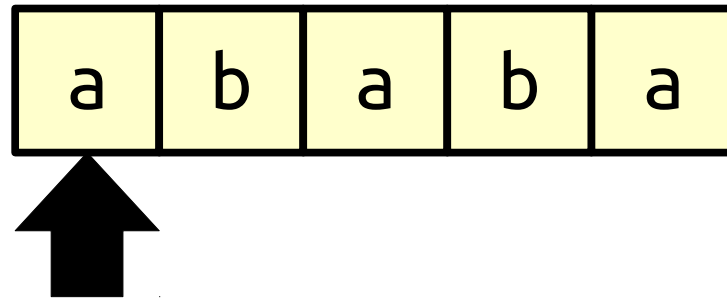
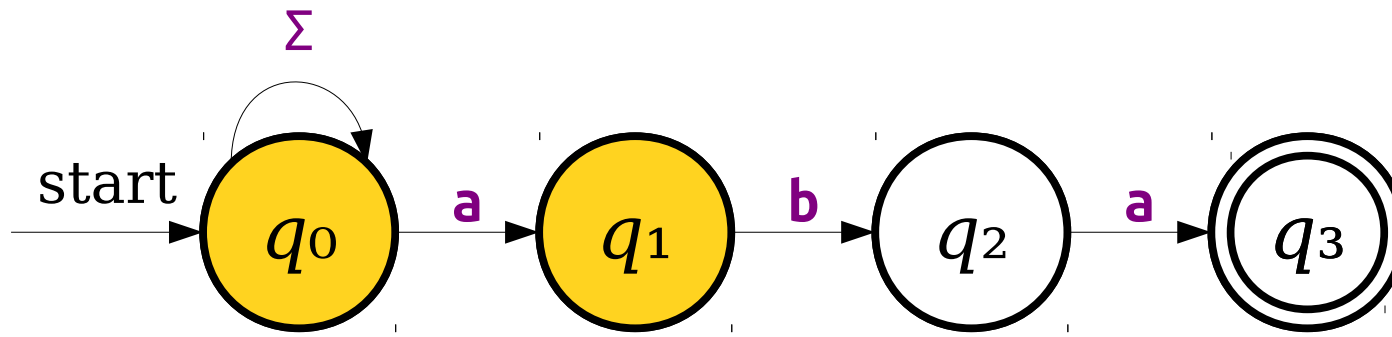

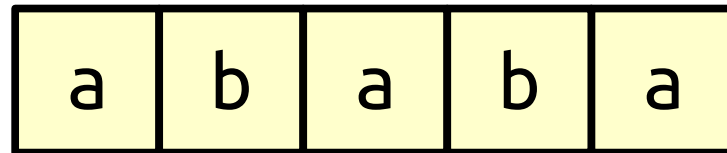
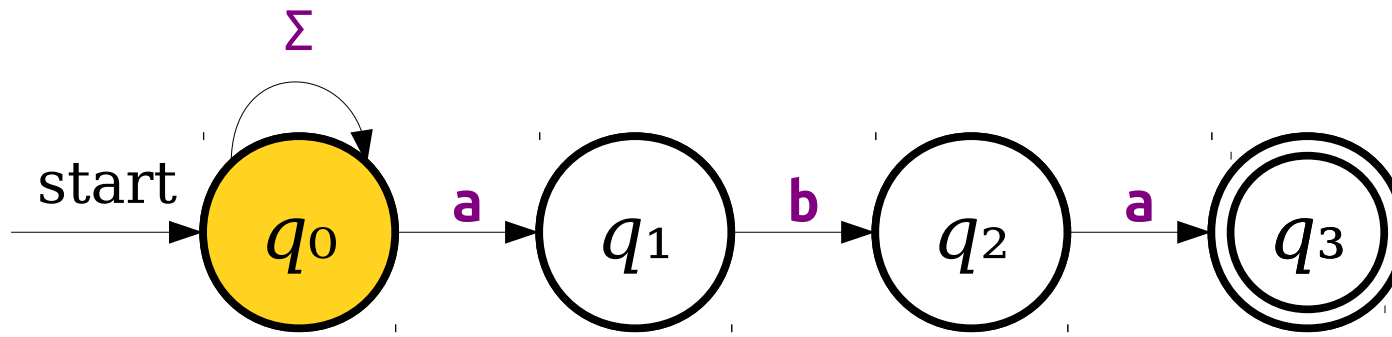

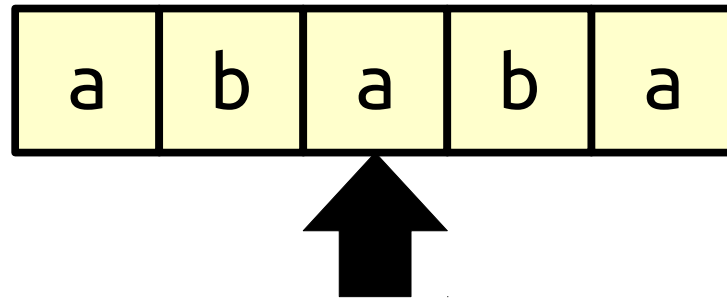
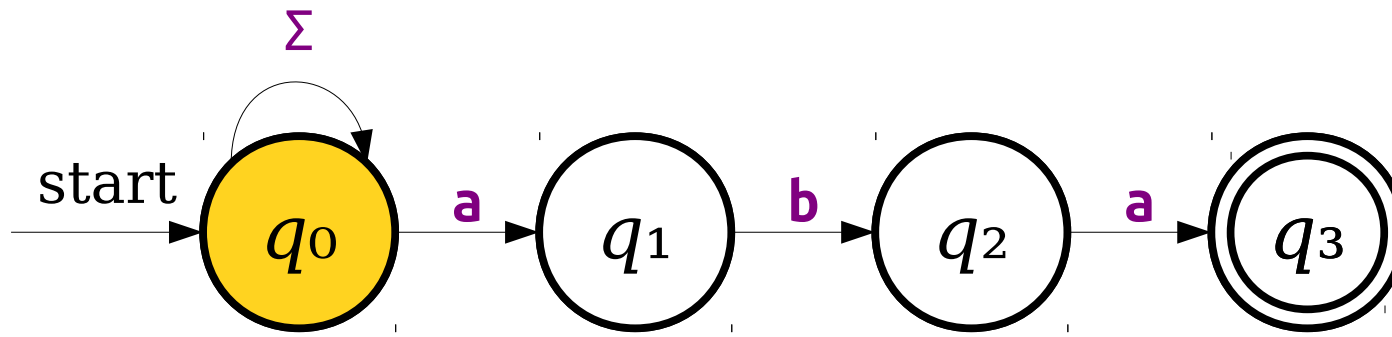

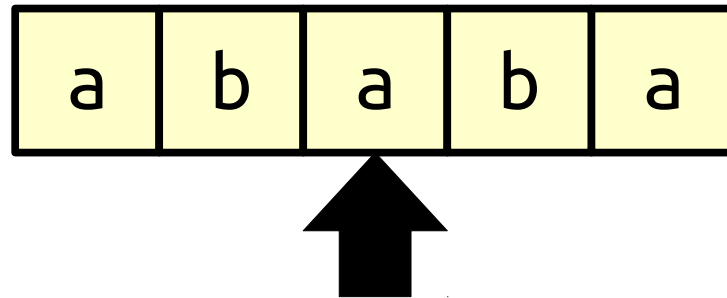
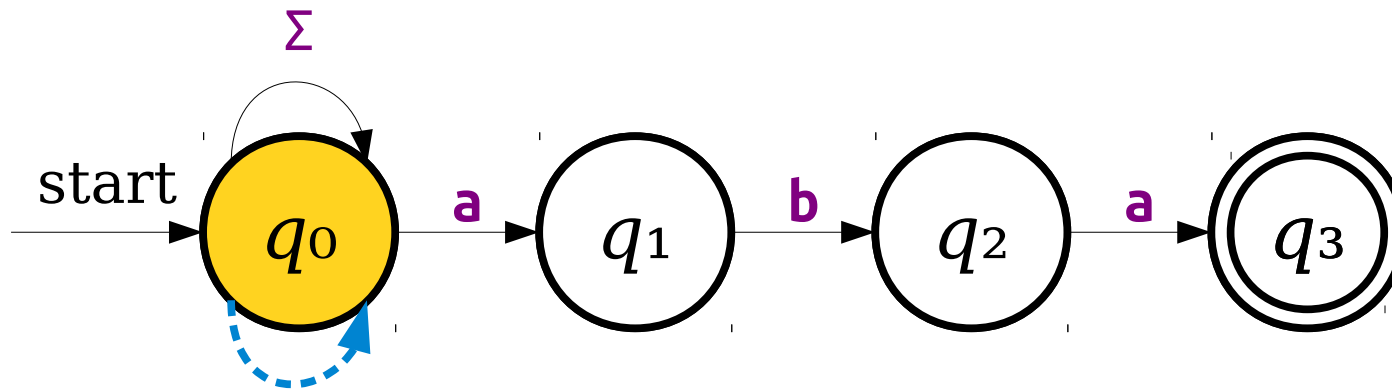

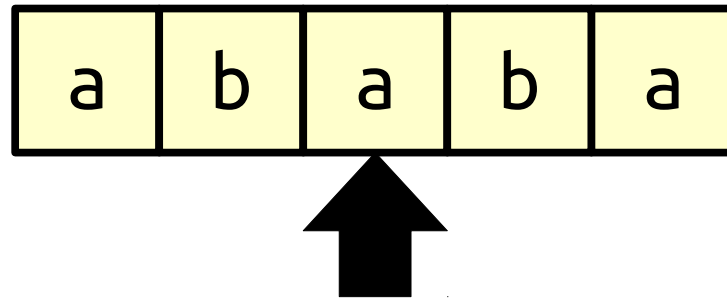
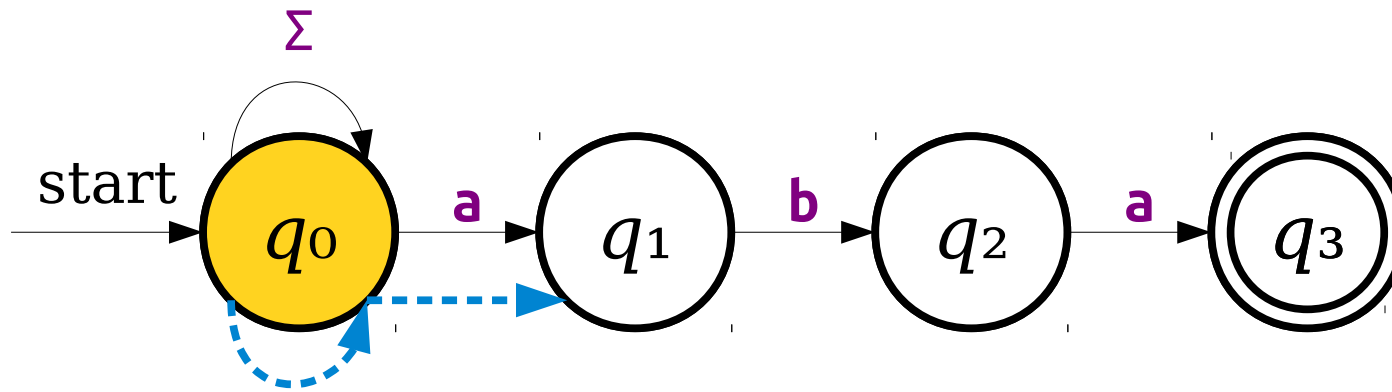

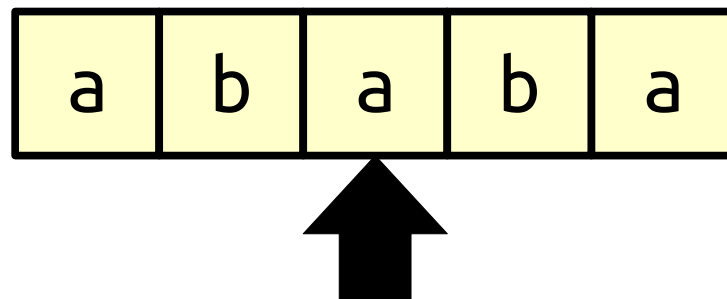
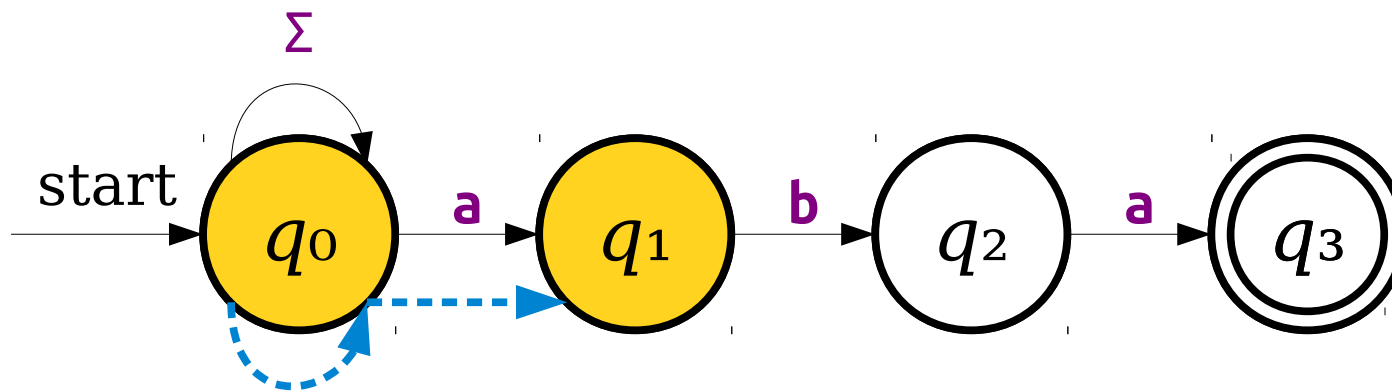

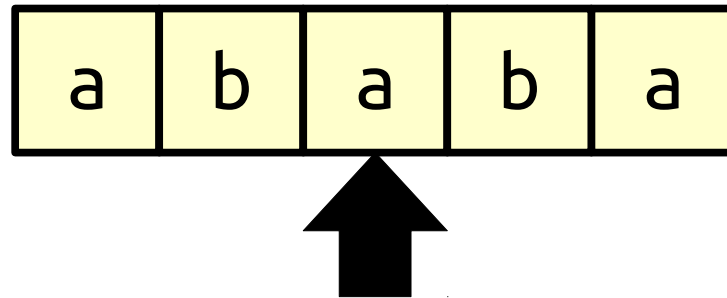
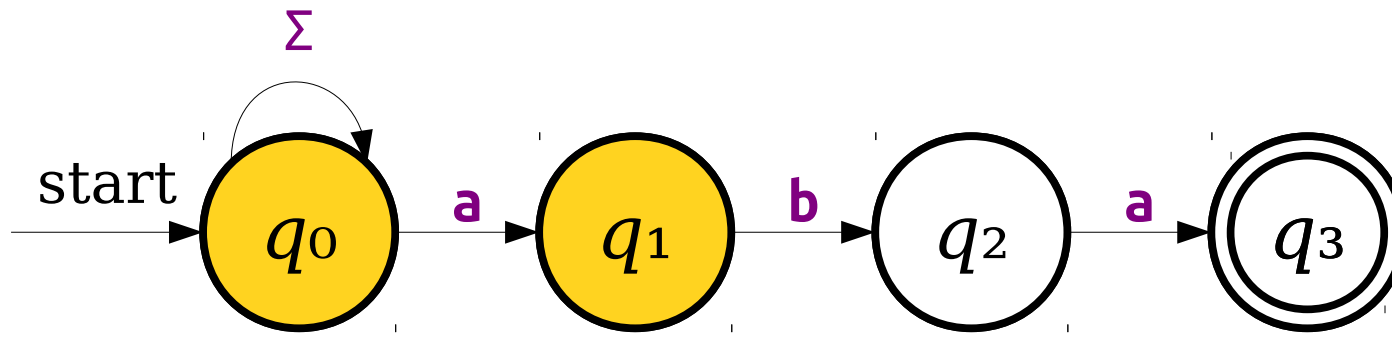

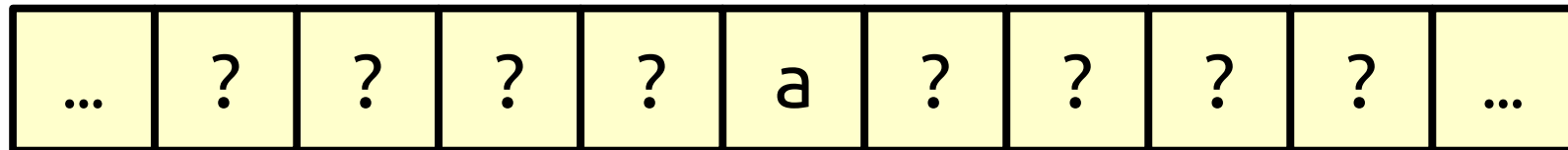
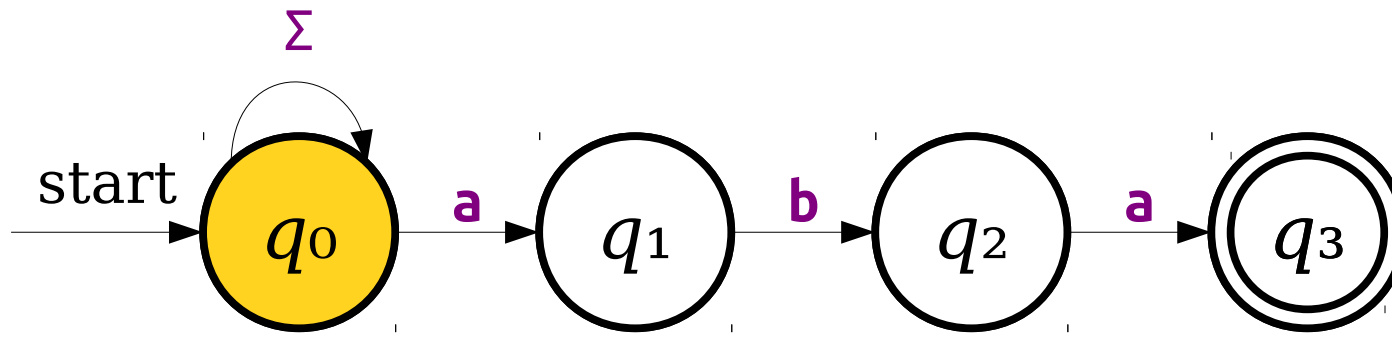

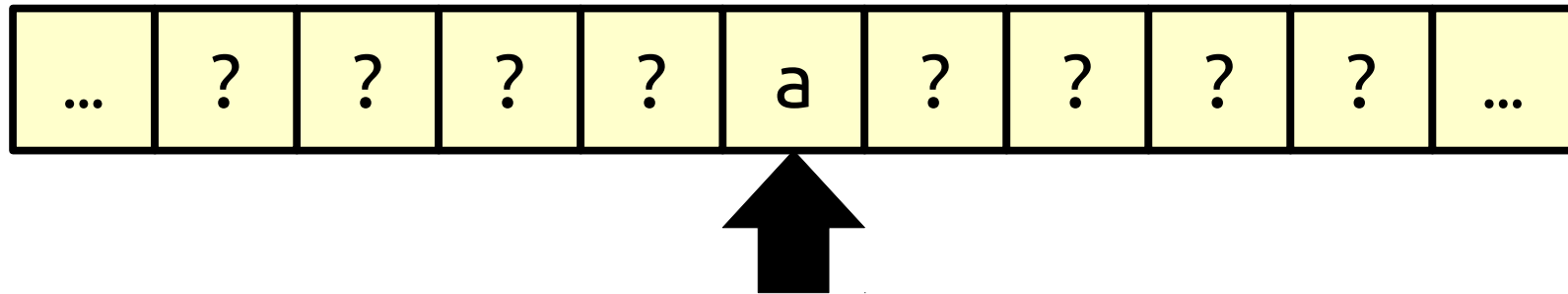
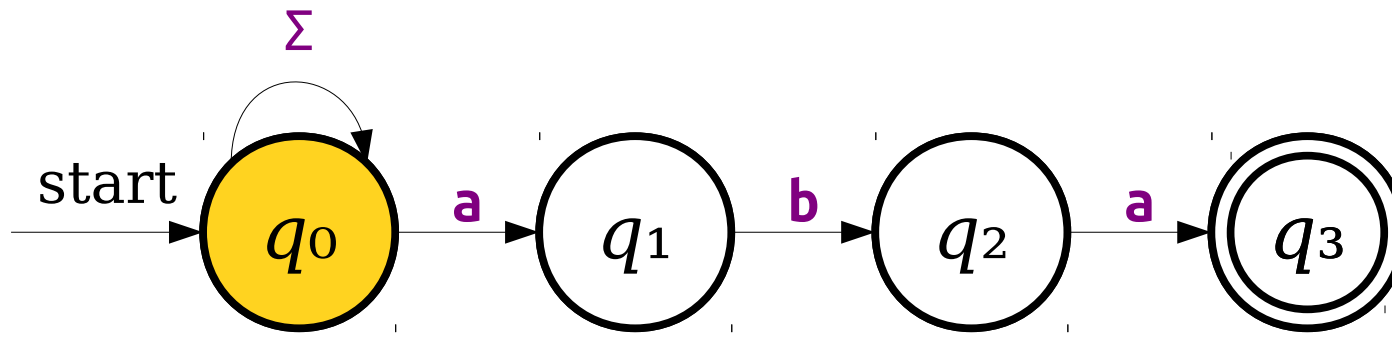

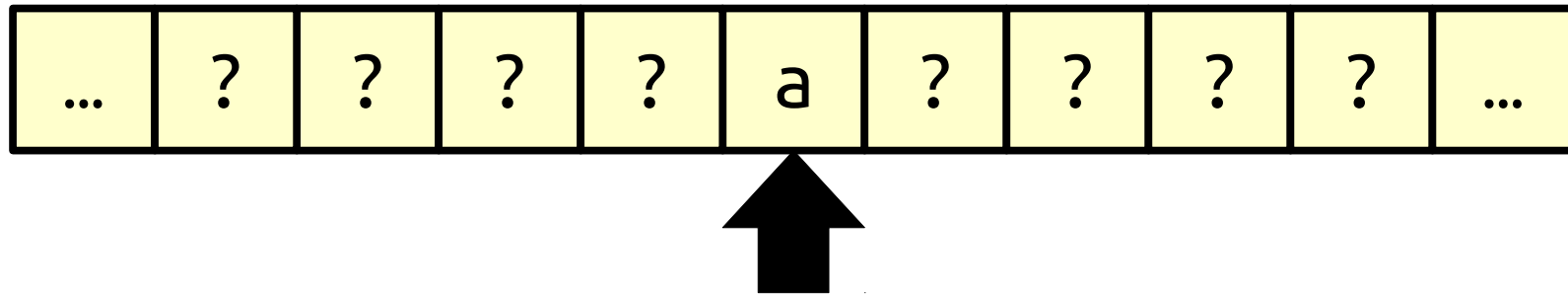
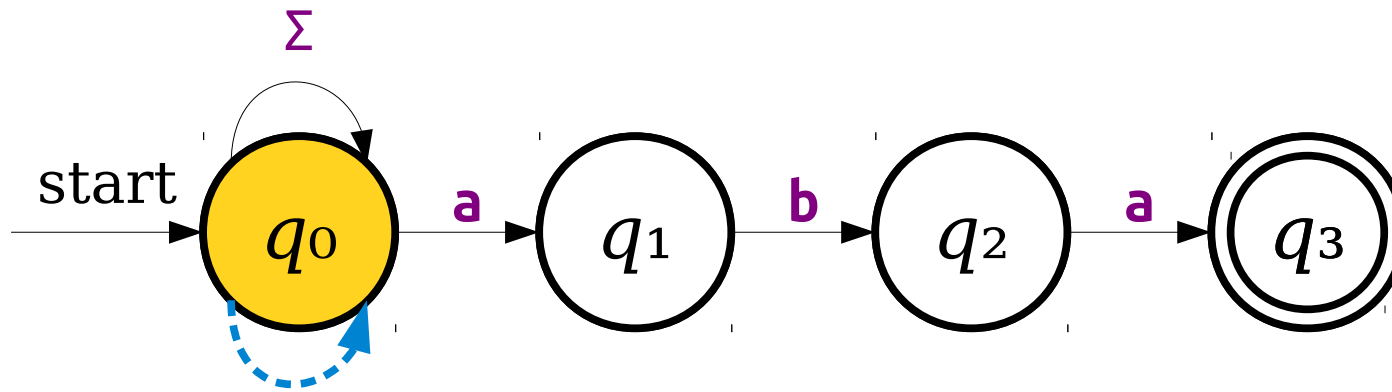

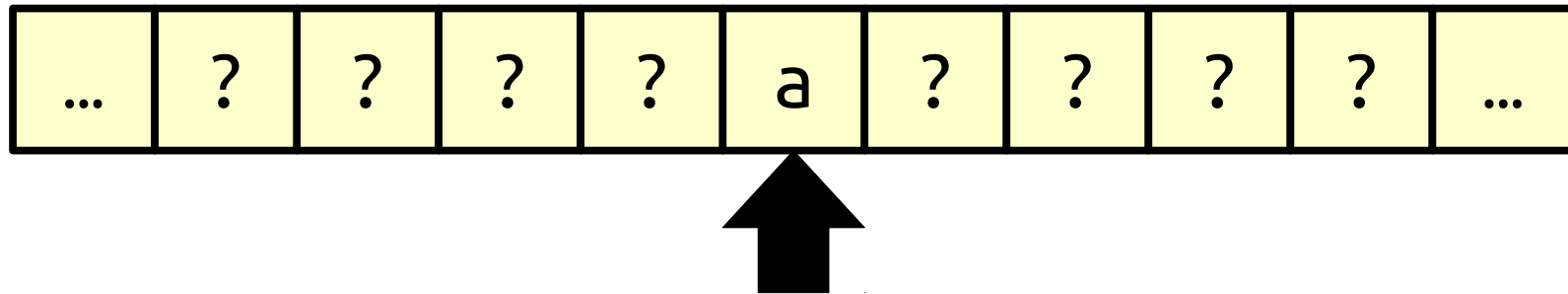
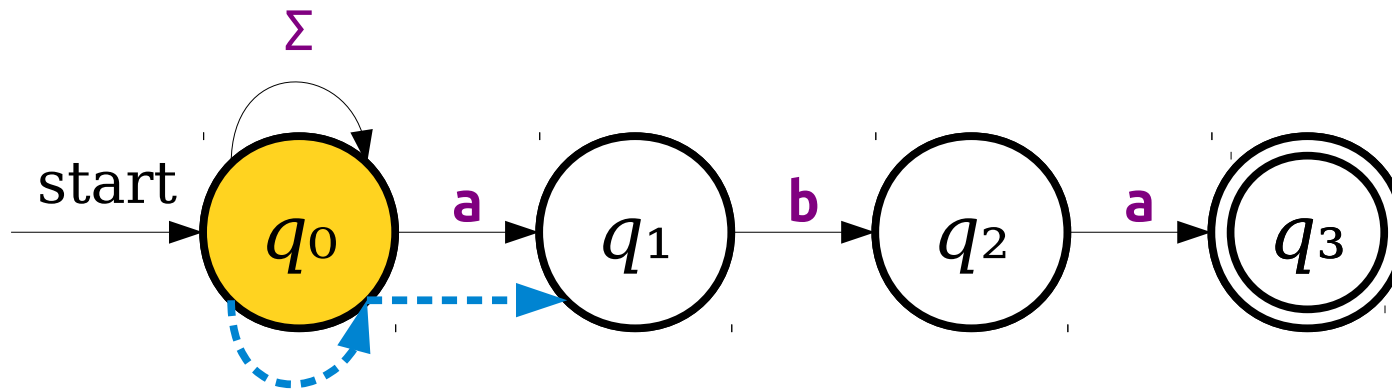

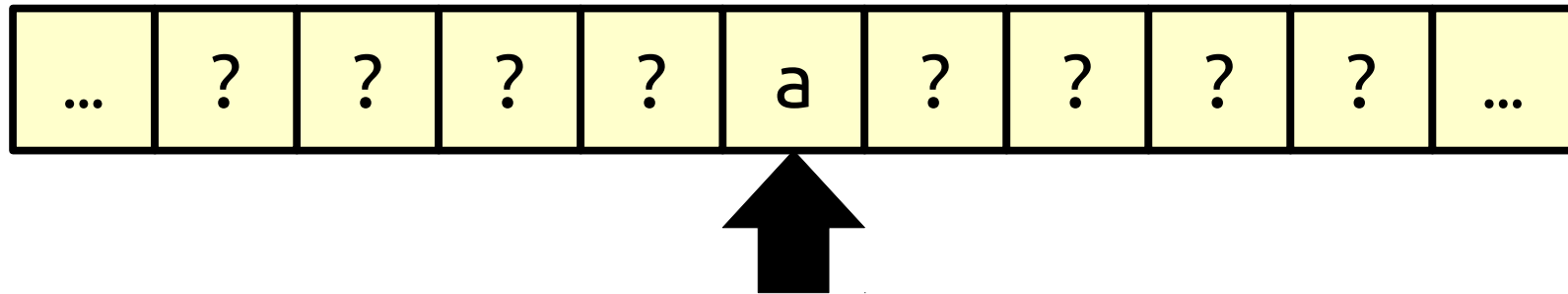
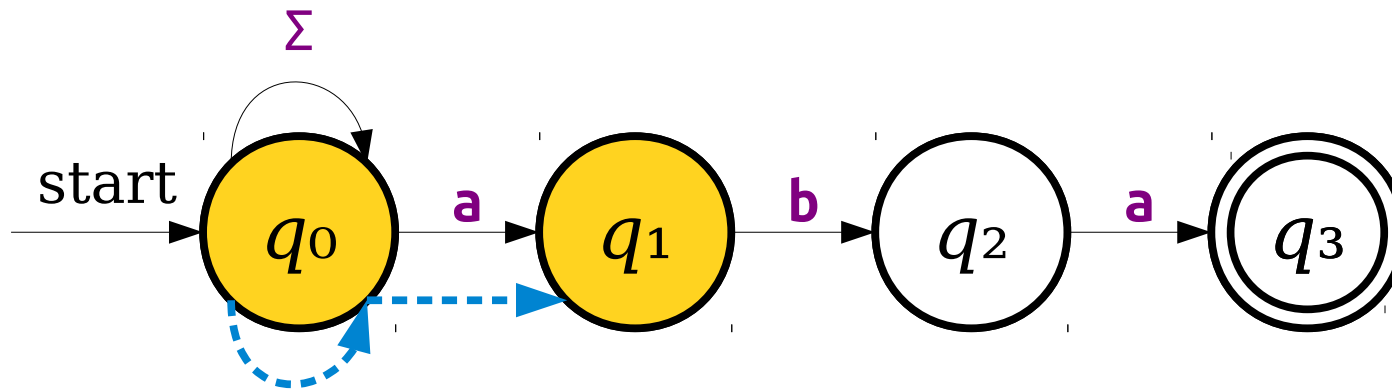

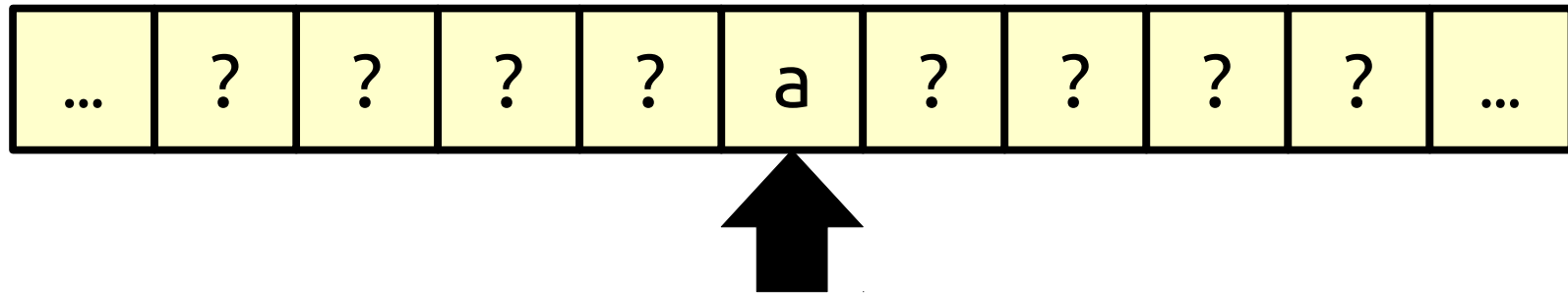
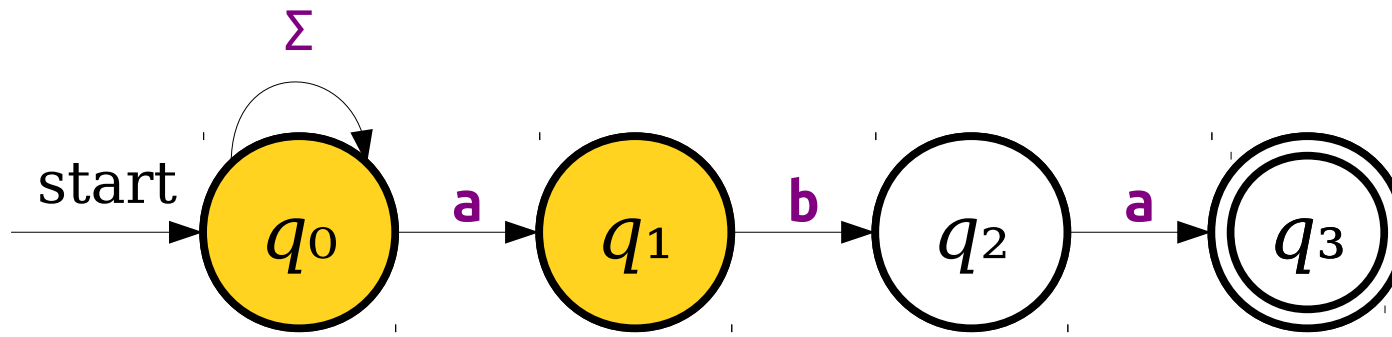

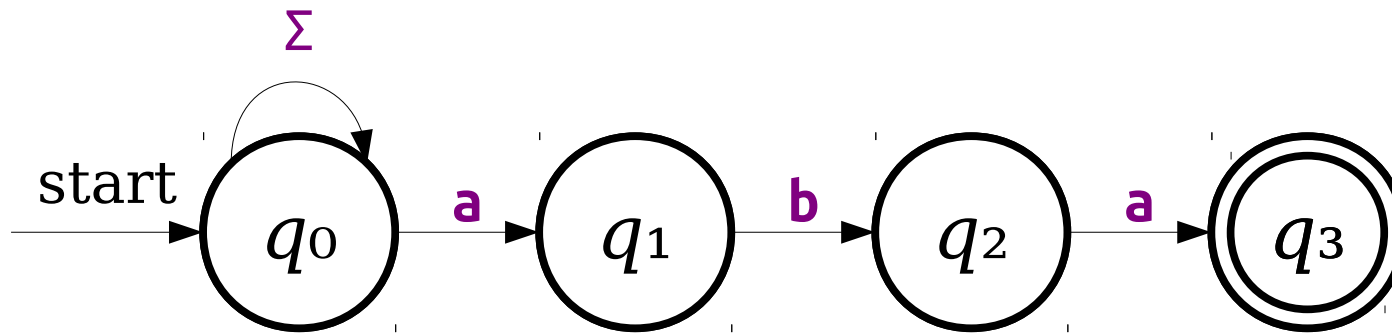

	$a$
$\{q_0\}$	$\{q_0, q_1\}$

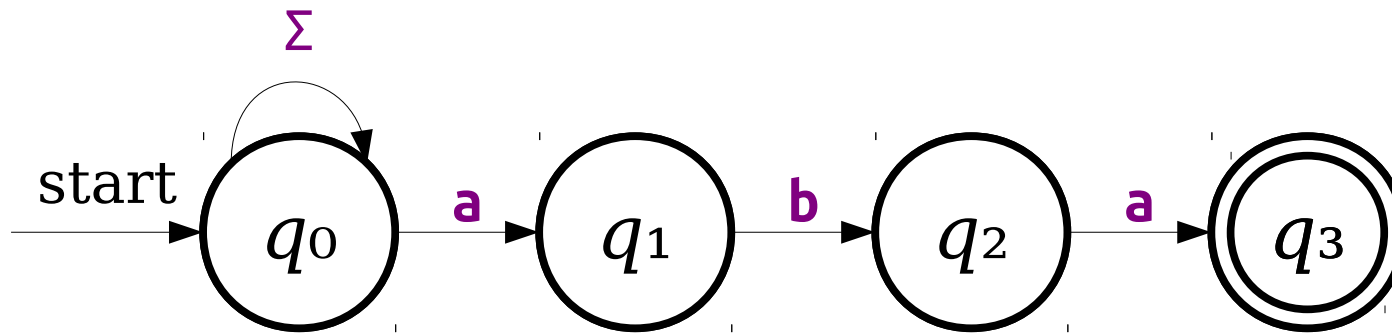

	$a$	$b$
$\{q_0\}$	$\{q_0, q_1\}$	

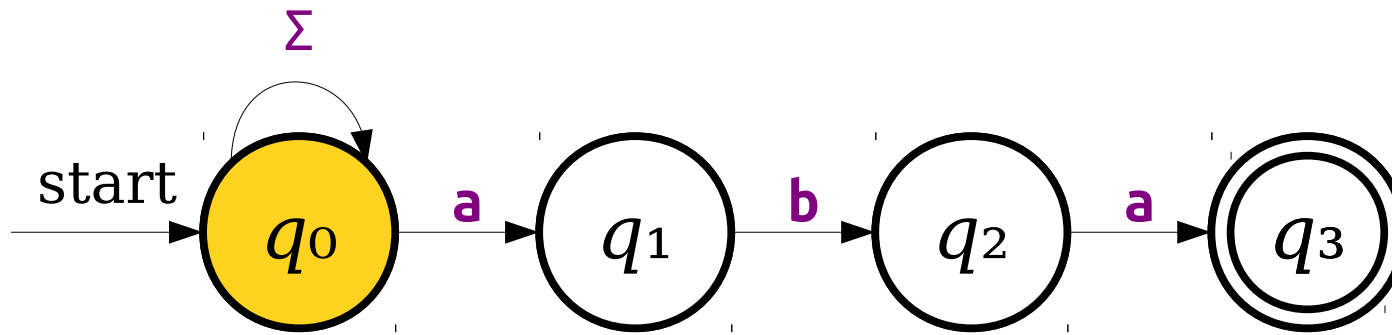

	$a$	$b$
$\{q_0\}$	$\{q_0, q_1\}$	

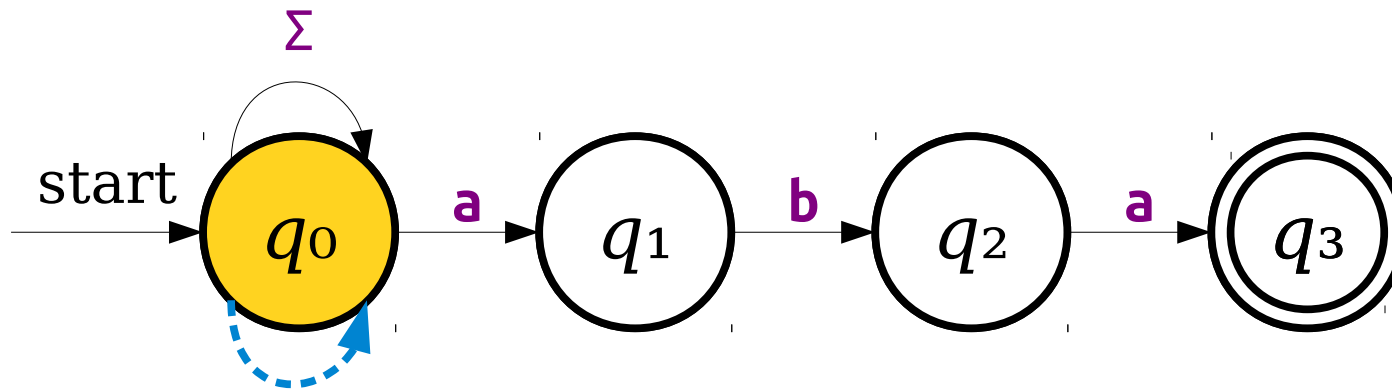

	$a$	$b$
$\{q_0\}$	$\{q_0, q_1\}$	

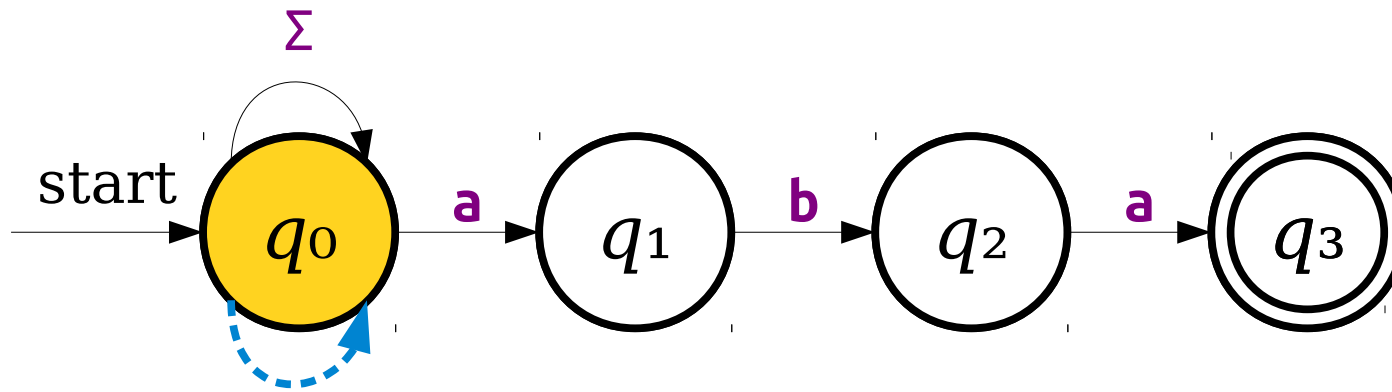

	$a$	$b$
$\{q_0\}$	$\{q_0, q_1\}$	$\{q_0\}$

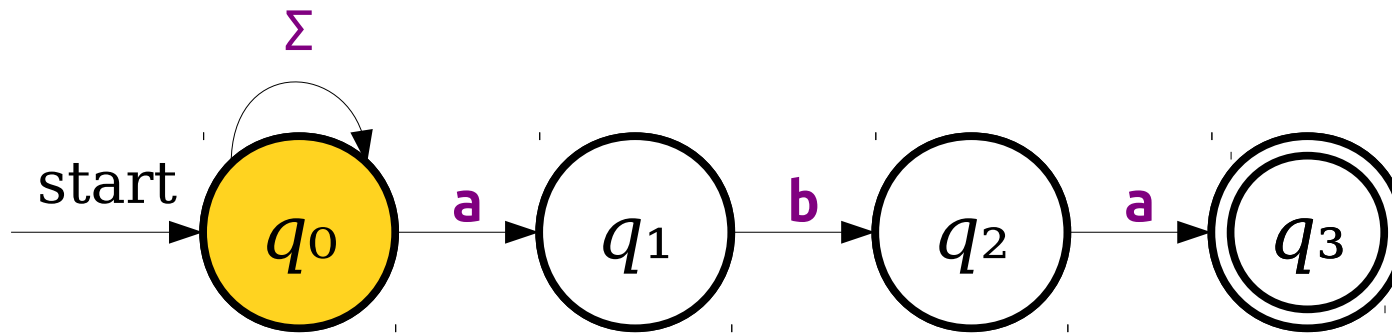

	$a$	$b$
$\{q_0\}$	$\{q_0, q_1\}$	$\{q_0\}$

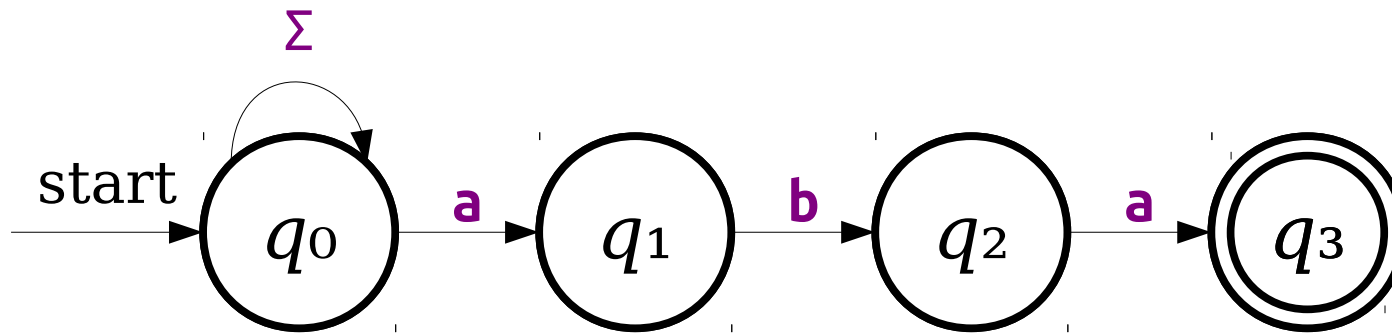

	$a$	$b$
$\{q_0\}$	$\{q_0, q_1\}$	$\{q_0\}$

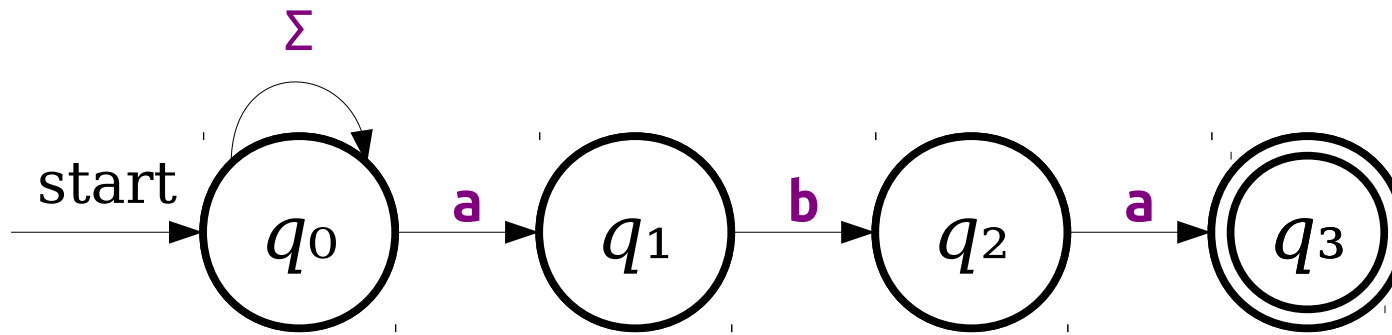

	$a$	$b$
$\{q_0\}$	$\{q_0, q_1\}$	$\{q_0\}$
$\{q_0, q_1\}$		

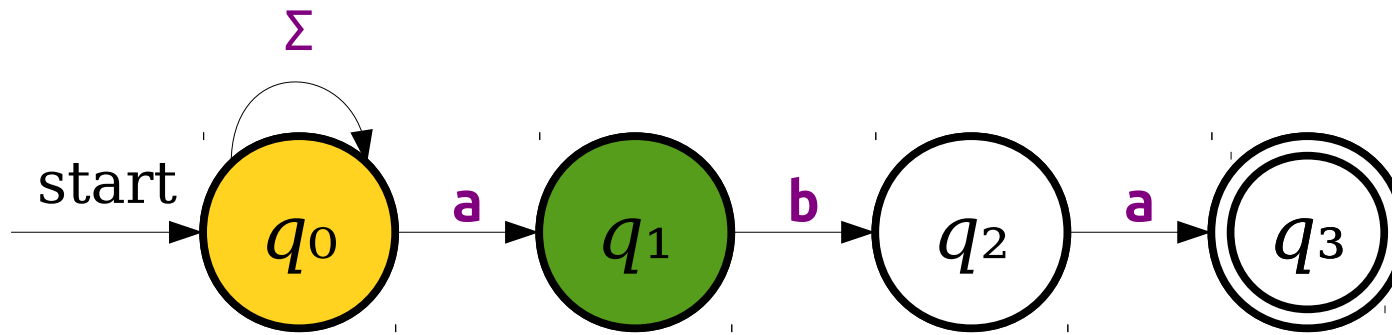

	$a$	$b$
$\{q_0\}$	$\{q_0, q_1\}$	$\{q_0\}$
$\{q_0, q_1\}$		

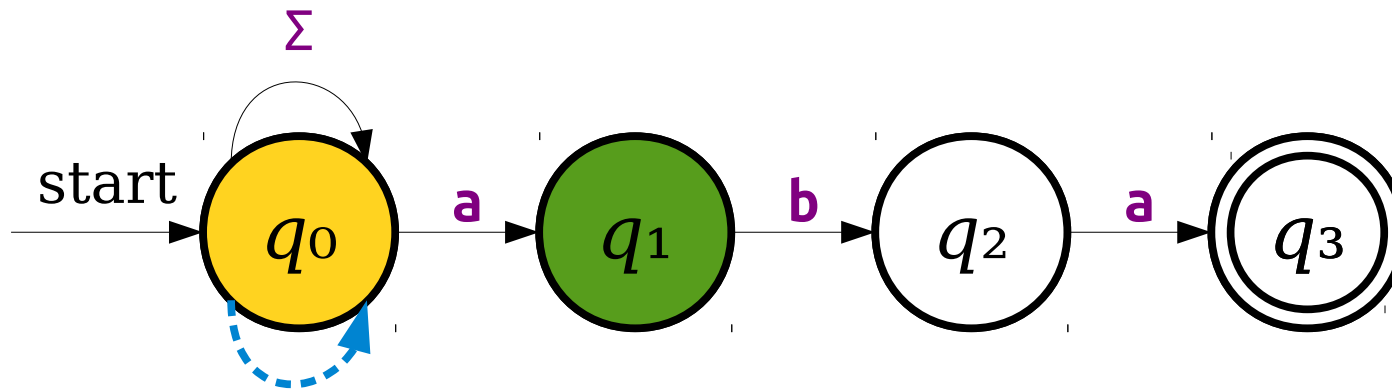

	$a$	$b$
$\{q_0\}$	$\{q_0, q_1\}$	$\{q_0\}$
$\{q_0, q_1\}$		

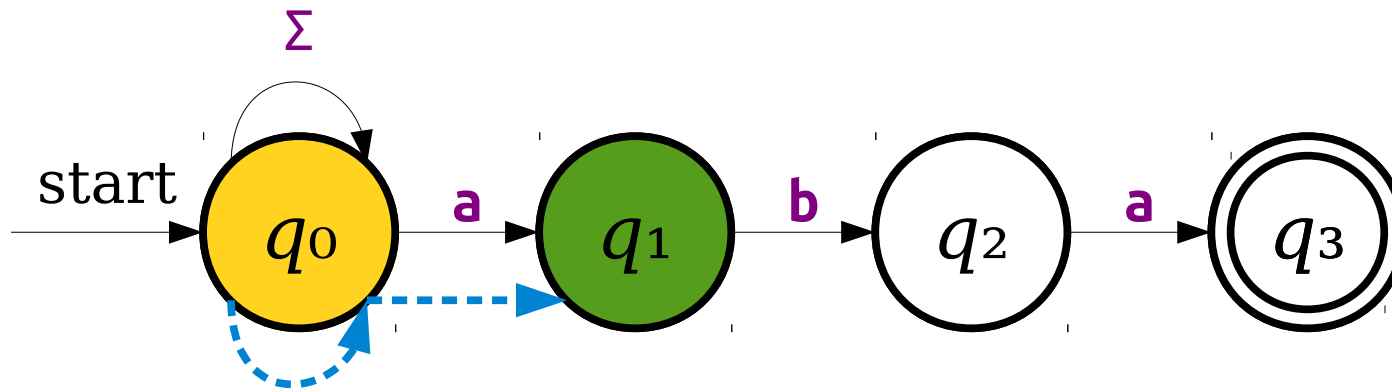

	$a$	$b$
$\{q_0\}$	$\{q_0, q_1\}$	$\{q_0\}$
$\{q_0, q_1\}$		

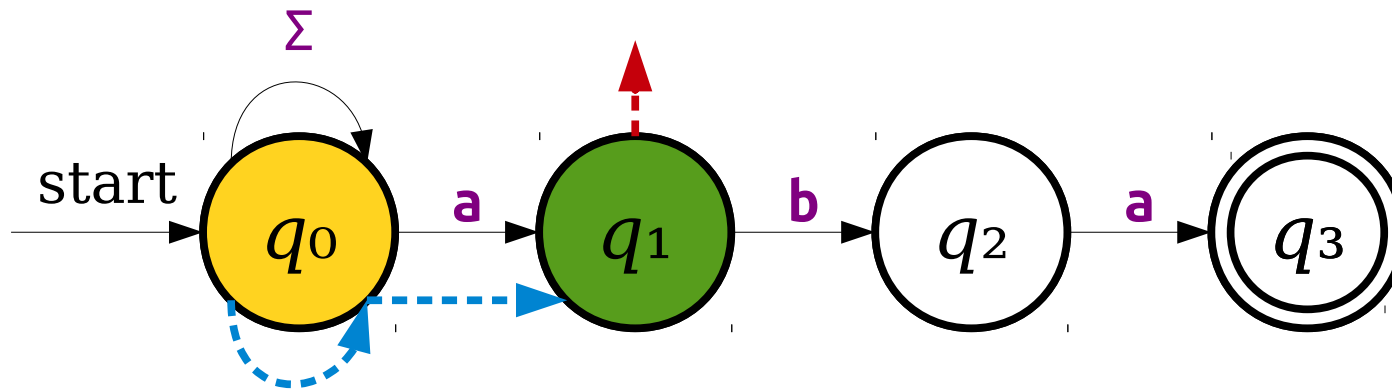

	$a$	$b$
$\{q_0\}$	$\{q_0, q_1\}$	$\{q_0\}$
$\{q_0, q_1\}$		

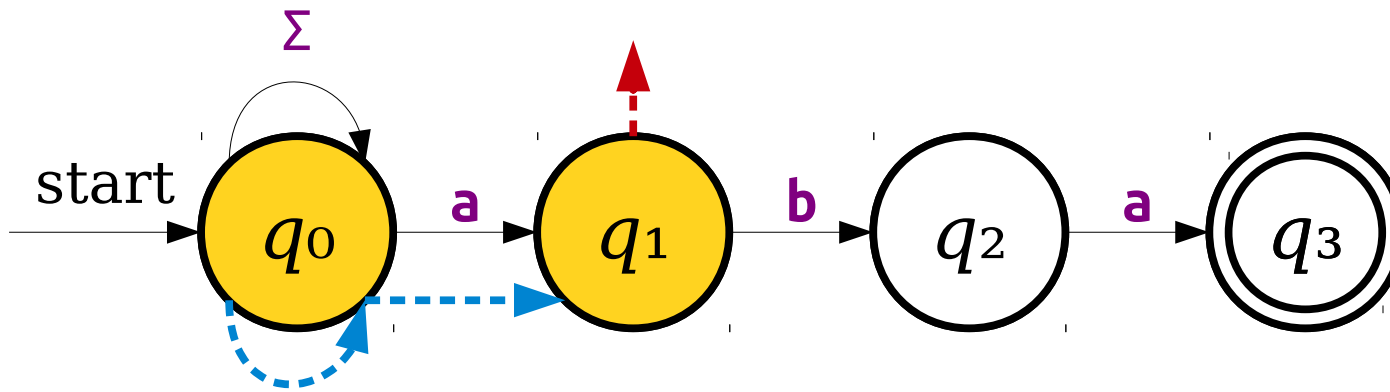

	$a$	$b$
$\{q_0\}$	$\{q_0, q_1\}$	$\{q_0\}$
$\{q_0, q_1\}$		

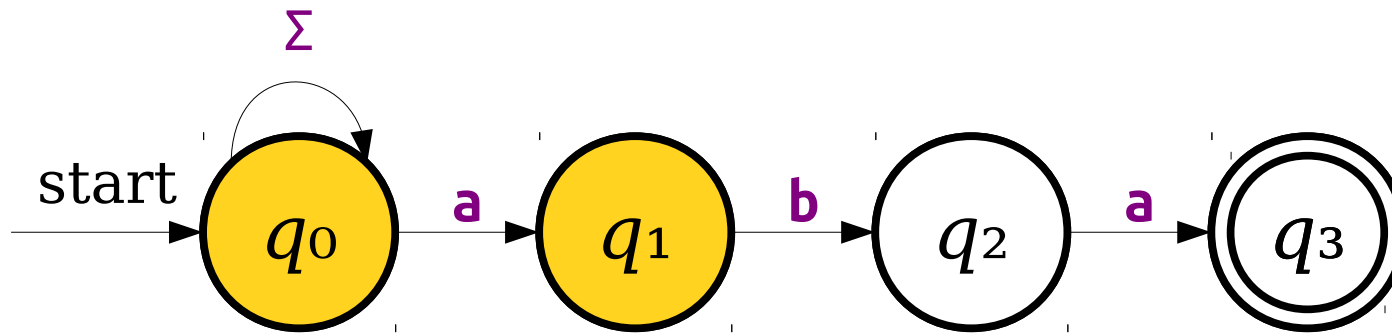

	$a$	$b$
$\{q_0\}$	$\{q_0, q_1\}$	$\{q_0\}$
$\{q_0, q_1\}$		

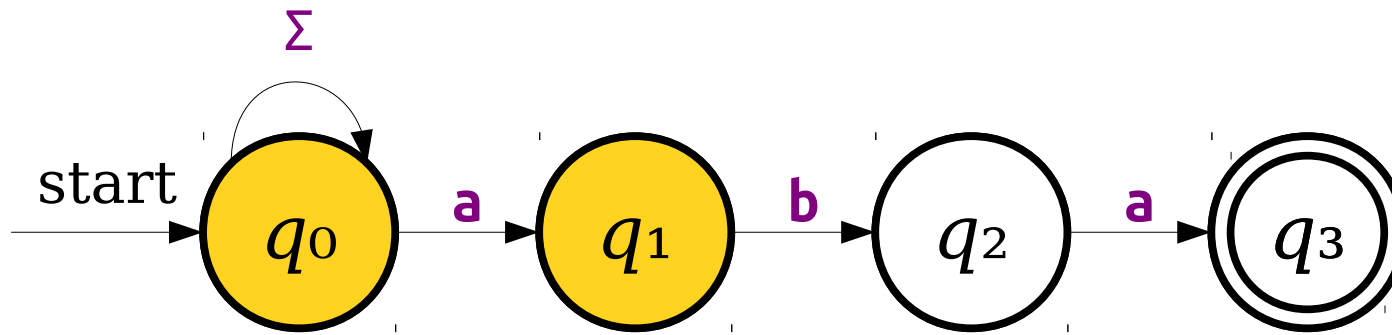

	$a$	$b$
$\{q_0\}$	$\{q_0, q_1\}$	$\{q_0\}$
$\{q_0, q_1\}$	$\{q_0, q_1\}$	

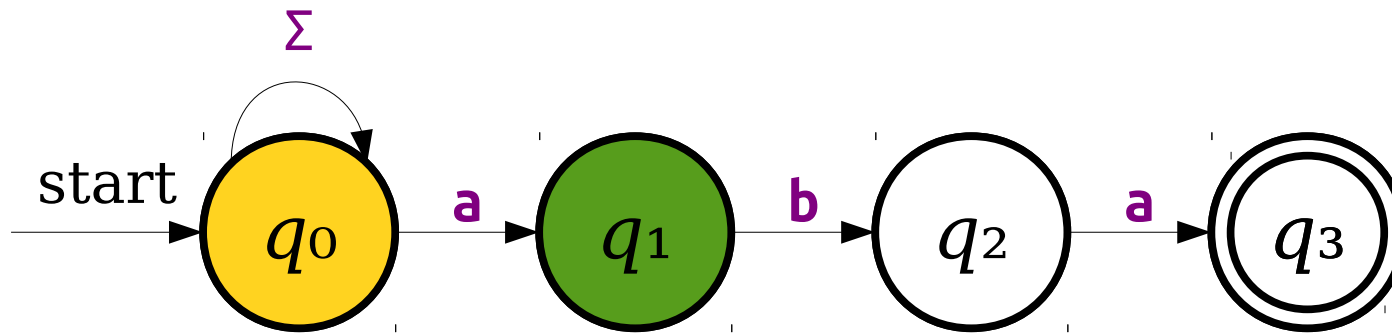

	$a$	$b$
$\{q_0\}$	$\{q_0, q_1\}$	$\{q_0\}$
$\{q_0, q_1\}$	$\{q_0, q_1\}$	

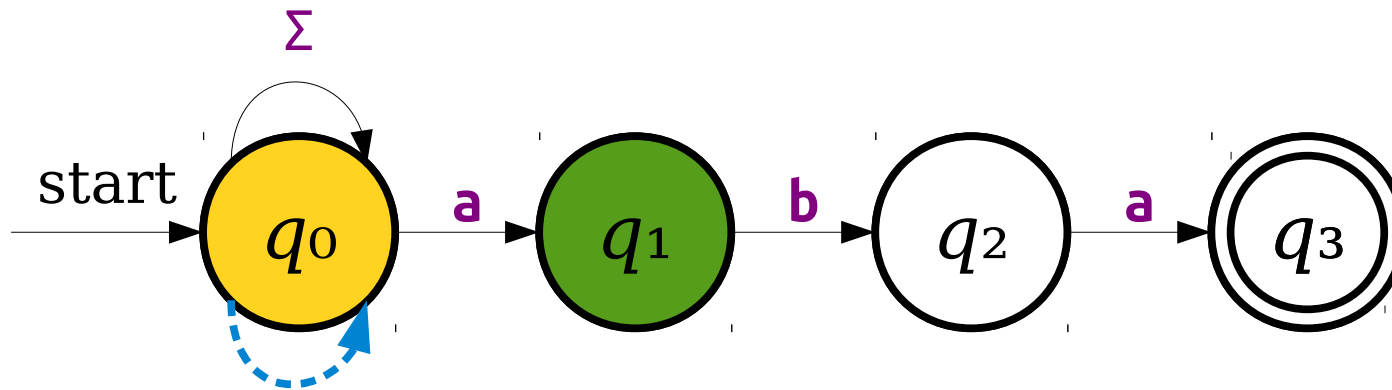

	$a$	$b$
$\{q_0\}$	$\{q_0, q_1\}$	$\{q_0\}$
$\{q_0, q_1\}$	$\{q_0, q_1\}$	

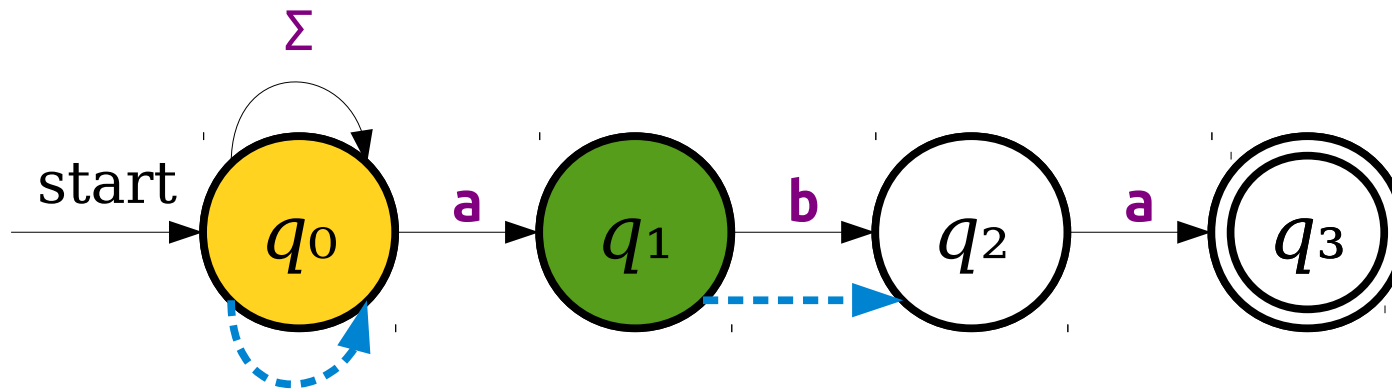

	$a$	$b$
$\{q_0\}$	$\{q_0, q_1\}$	$\{q_0\}$
$\{q_0, q_1\}$	$\{q_0, q_1\}$	

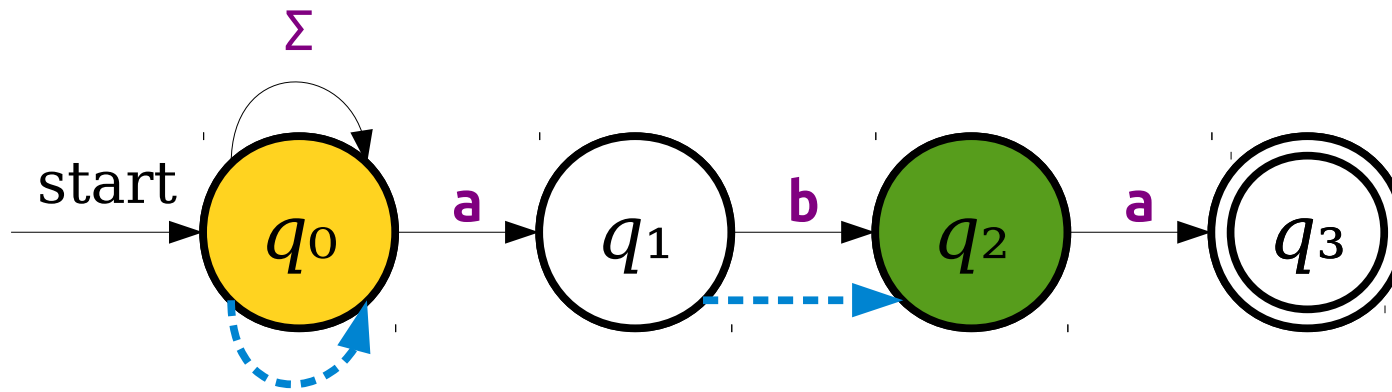

	$a$	$b$
$\{q_0\}$	$\{q_0, q_1\}$	$\{q_0\}$
$\{q_0, q_1\}$	$\{q_0, q_1\}$	

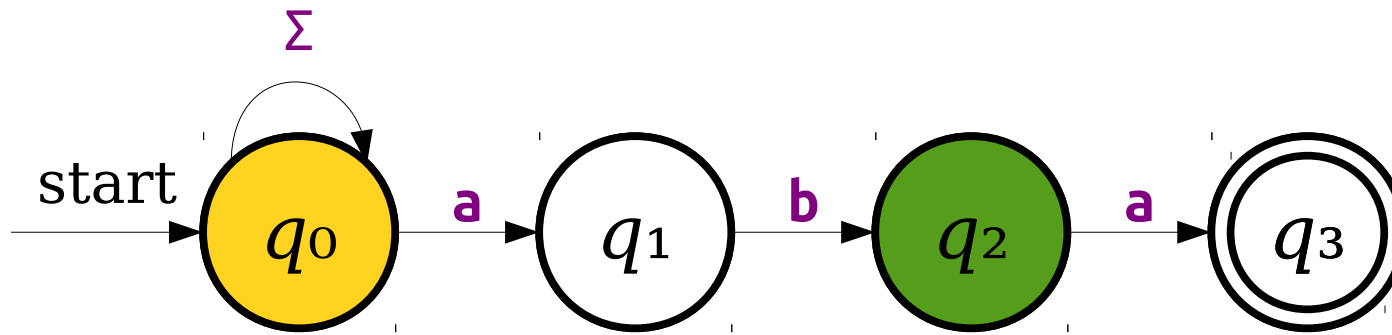

	$a$	$b$
$\{q_0\}$	$\{q_0, q_1\}$	$\{q_0\}$
$\{q_0, q_1\}$	$\{q_0, q_1\}$	$\{q_0, q_2\}$

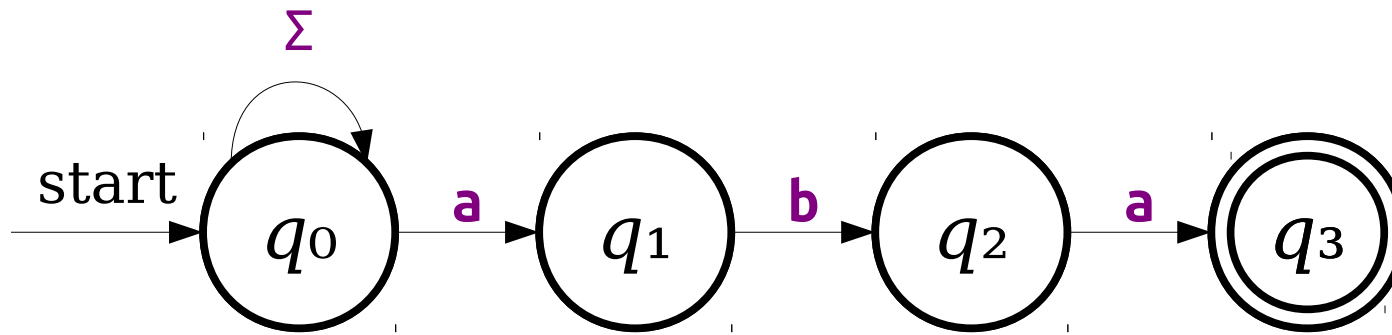

	$a$	$b$
$\{q_0\}$	$\{q_0, q_1\}$	$\{q_0\}$
$\{q_0, q_1\}$	$\{q_0, q_1\}$	$\{q_0, q_2\}$

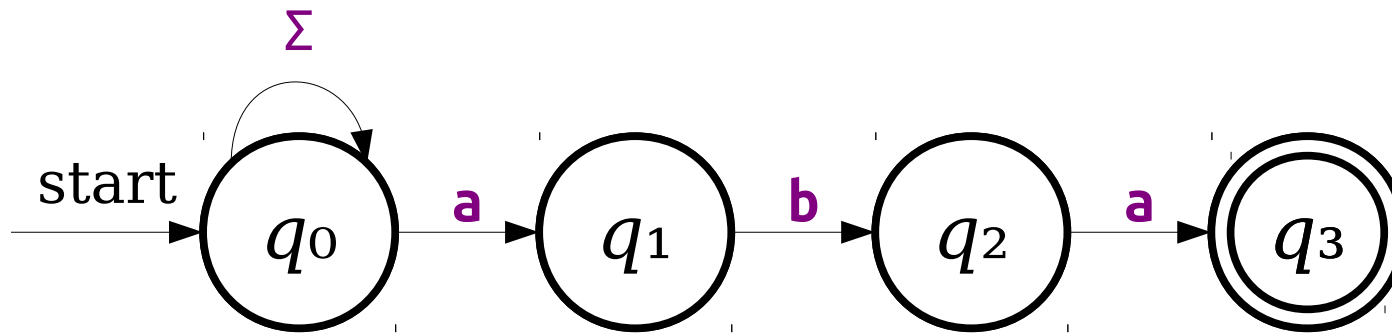

	<i>a</i>	<i>b</i>
$\{q_0\}$	$\{q_0, q_1\}$	$\{q_0\}$
$\{q_0, q_1\}$	$\{q_0, q_1\}$	$\{q_0, q_2\}$
$\{q_0, q_2\}$		

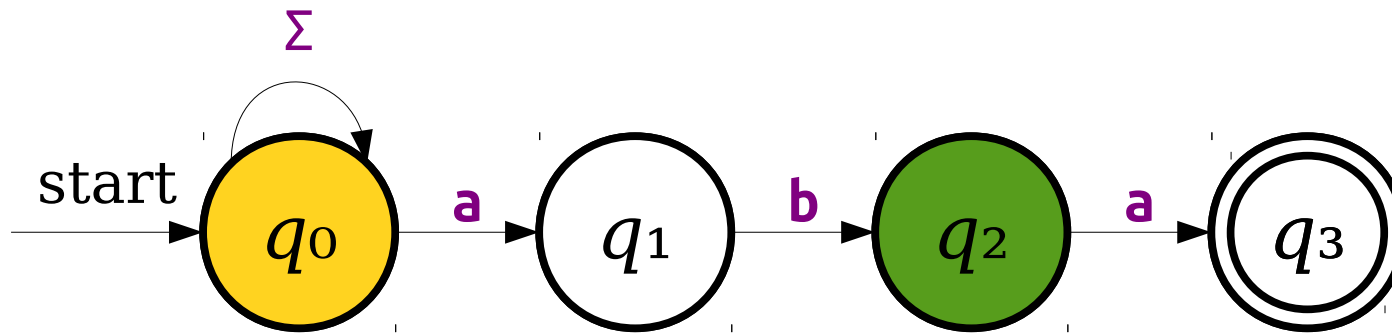

	$a$	$b$
$\{q_0\}$	$\{q_0, q_1\}$	$\{q_0\}$
$\{q_0, q_1\}$	$\{q_0, q_1\}$	$\{q_0, q_2\}$
$\{q_0, q_2\}$		

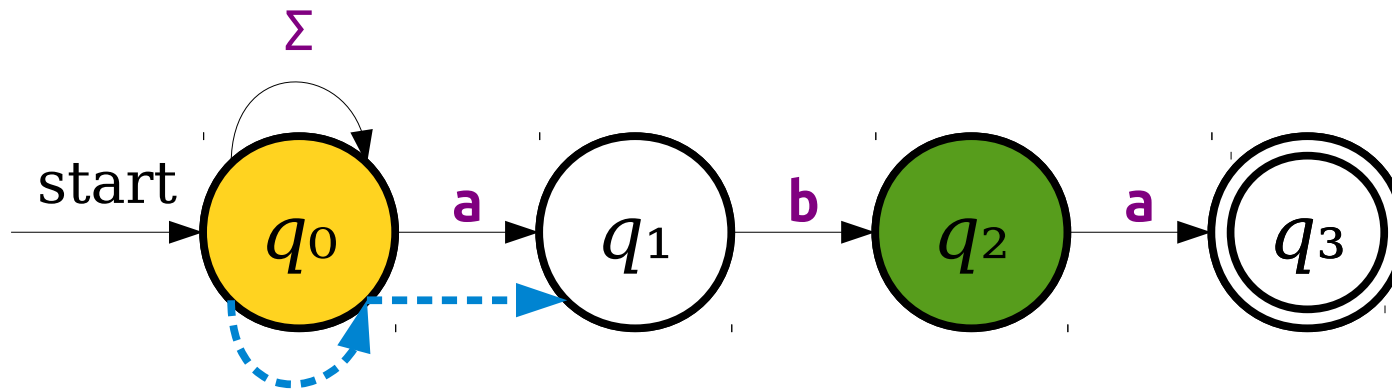

	$a$	$b$
$\{q_0\}$	$\{q_0, q_1\}$	$\{q_0\}$
$\{q_0, q_1\}$	$\{q_0, q_1\}$	$\{q_0, q_2\}$
$\{q_0, q_2\}$		

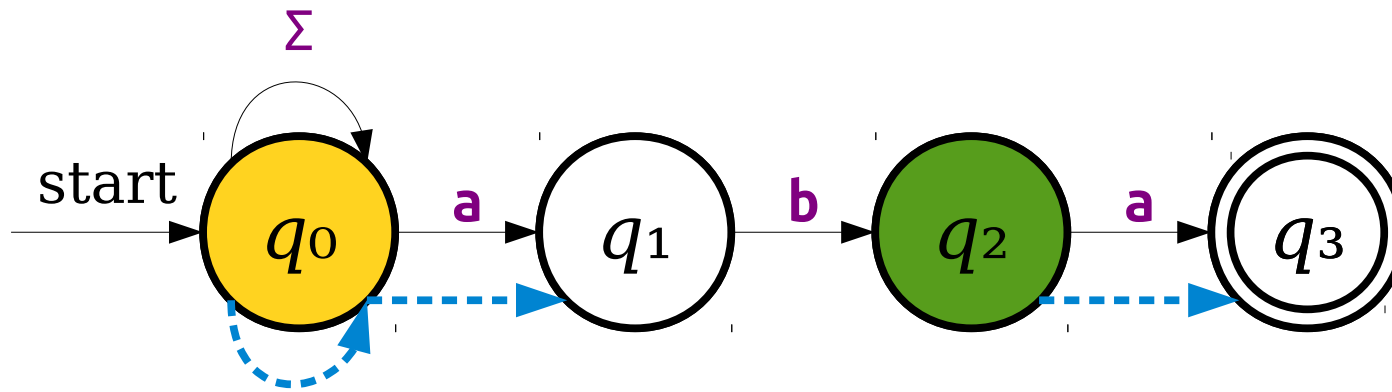

	$a$	$b$
$\{q_0\}$	$\{q_0, q_1\}$	$\{q_0\}$
$\{q_0, q_1\}$	$\{q_0, q_1\}$	$\{q_0, q_2\}$
$\{q_0, q_2\}$		

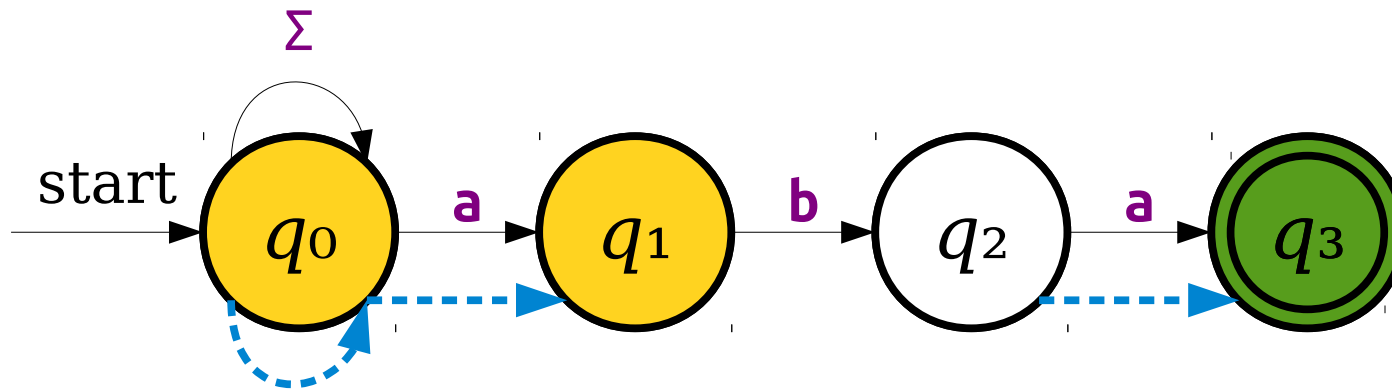

	$a$	$b$
$\{q_0\}$	$\{q_0, q_1\}$	$\{q_0\}$
$\{q_0, q_1\}$	$\{q_0, q_1\}$	$\{q_0, q_2\}$
$\{q_0, q_2\}$		

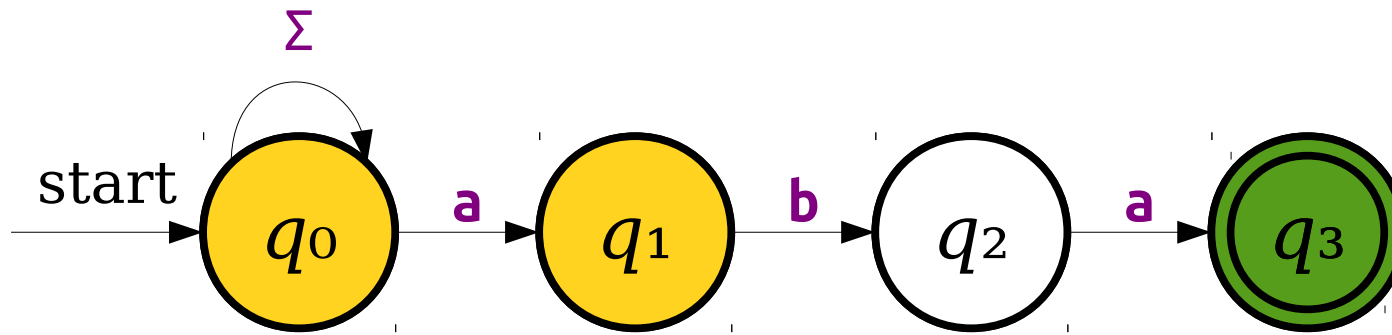

	$a$	$b$
$\{q_0\}$	$\{q_0, q_1\}$	$\{q_0\}$
$\{q_0, q_1\}$	$\{q_0, q_1\}$	$\{q_0, q_2\}$
$\{q_0, q_2\}$		

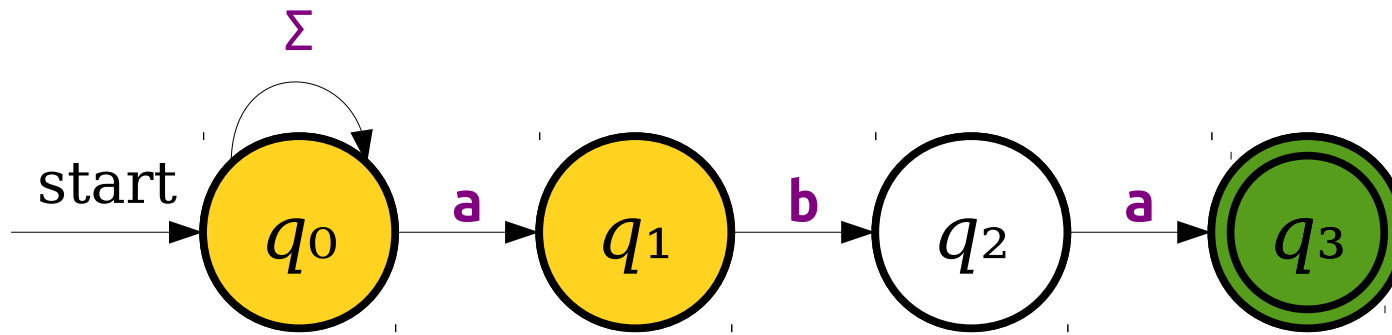

	$a$	$b$
$\{q_0\}$	$\{q_0, q_1\}$	$\{q_0\}$
$\{q_0, q_1\}$	$\{q_0, q_1\}$	$\{q_0, q_2\}$
$\{q_0, q_2\}$	$\{q_0, q_1, q_3\}$	

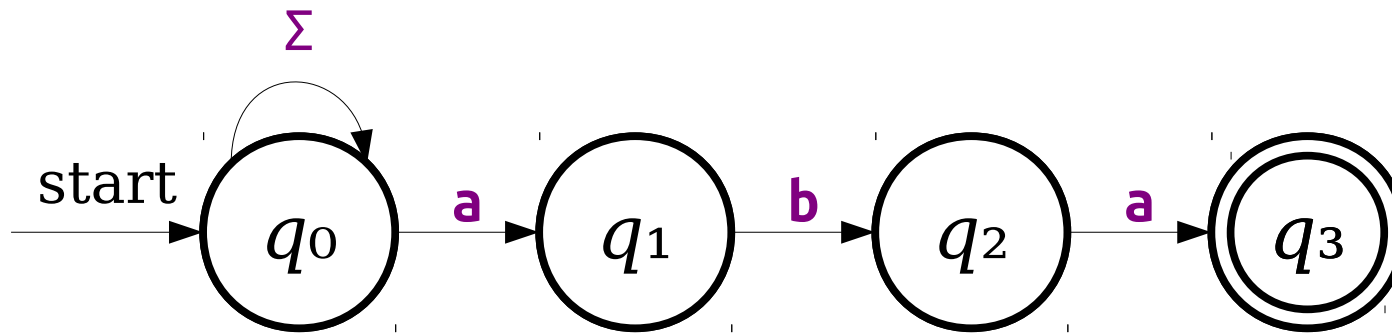

	<i>a</i>	<i>b</i>
$\{q_0\}$	$\{q_0, q_1\}$	$\{q_0\}$
$\{q_0, q_1\}$	$\{q_0, q_1\}$	$\{q_0, q_2\}$
$\{q_0, q_2\}$	$\{q_0, q_1, q_3\}$	

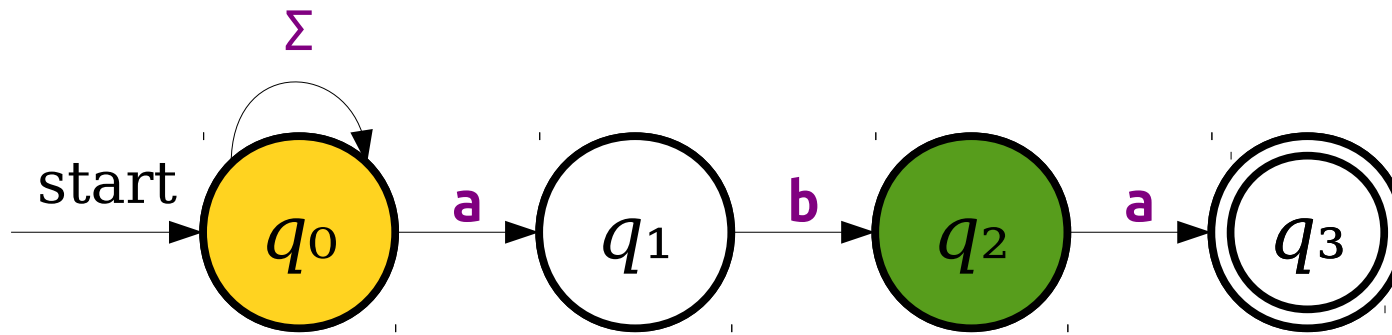

	$a$	$b$
$\{q_0\}$	$\{q_0, q_1\}$	$\{q_0\}$
$\{q_0, q_1\}$	$\{q_0, q_1\}$	$\{q_0, q_2\}$
$\{q_0, q_2\}$	$\{q_0, q_1, q_3\}$	

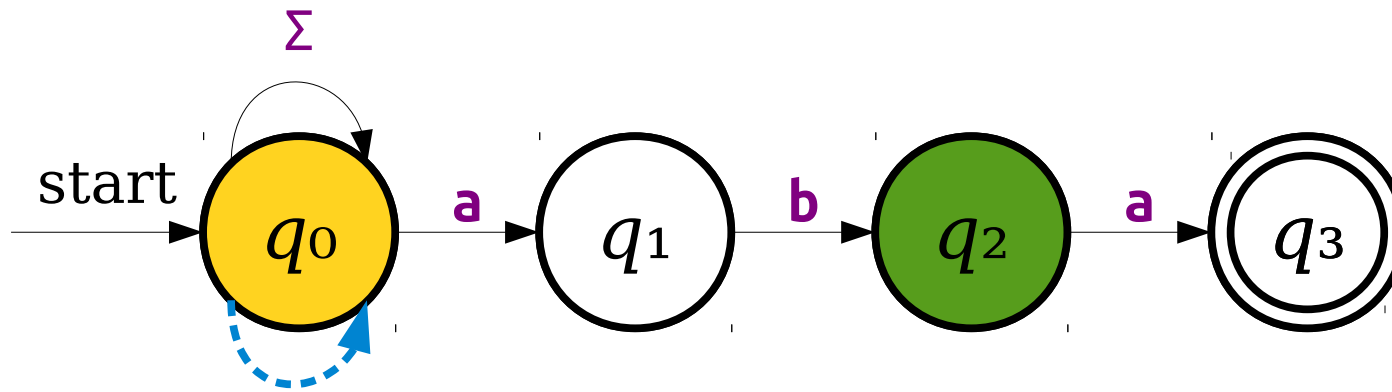

	$a$	$b$
$\{q_0\}$	$\{q_0, q_1\}$	$\{q_0\}$
$\{q_0, q_1\}$	$\{q_0, q_1\}$	$\{q_0, q_2\}$
$\{q_0, q_2\}$	$\{q_0, q_1, q_3\}$	

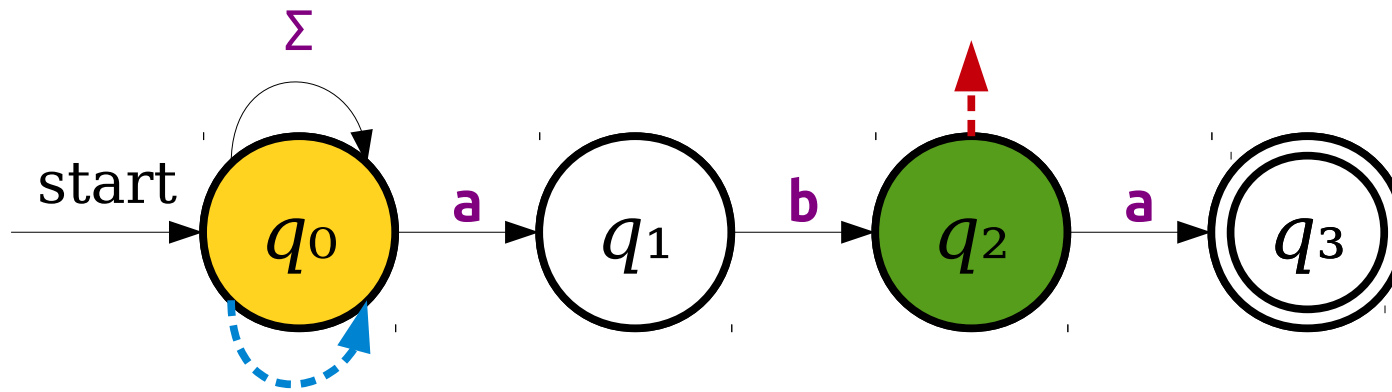

	$a$	$b$
$\{q_0\}$	$\{q_0, q_1\}$	$\{q_0\}$
$\{q_0, q_1\}$	$\{q_0, q_1\}$	$\{q_0, q_2\}$
$\{q_0, q_2\}$	$\{q_0, q_1, q_3\}$	

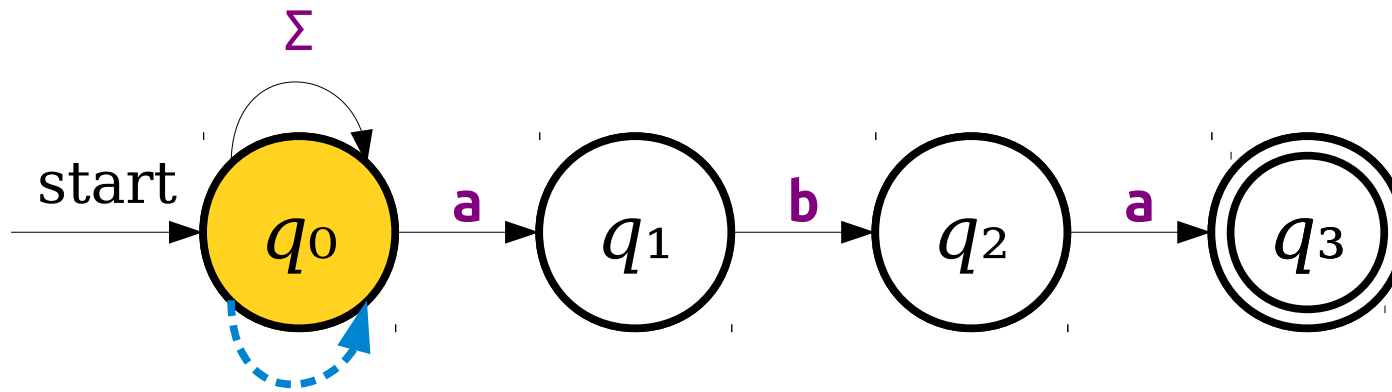

	$a$	$b$
$\{q_0\}$	$\{q_0, q_1\}$	$\{q_0\}$
$\{q_0, q_1\}$	$\{q_0, q_1\}$	$\{q_0, q_2\}$
$\{q_0, q_2\}$	$\{q_0, q_1, q_3\}$	

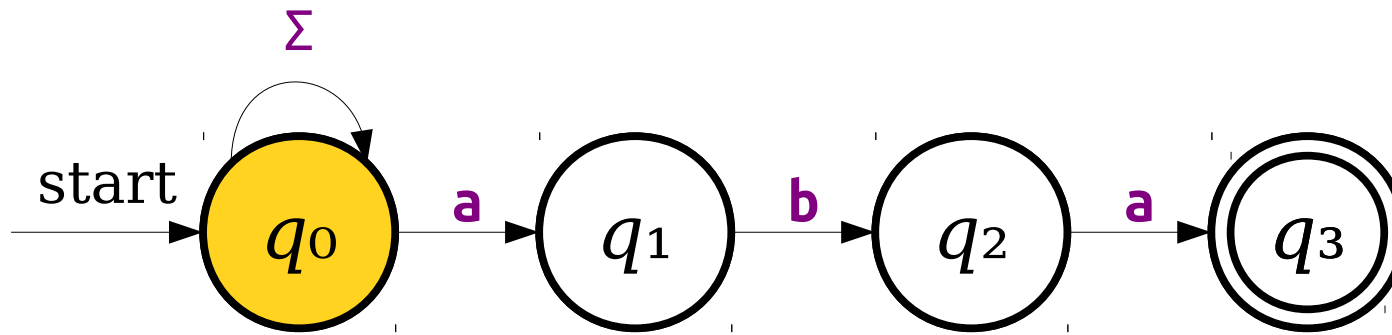

	$a$	$b$
$\{q_0\}$	$\{q_0, q_1\}$	$\{q_0\}$
$\{q_0, q_1\}$	$\{q_0, q_1\}$	$\{q_0, q_2\}$
$\{q_0, q_2\}$	$\{q_0, q_1, q_3\}$	

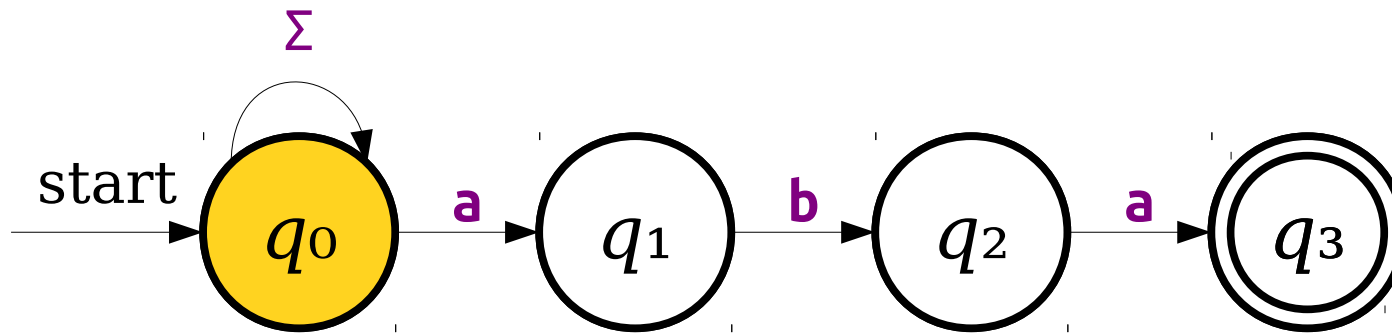

	$a$	$b$
$\{q_0\}$	$\{q_0, q_1\}$	$\{q_0\}$
$\{q_0, q_1\}$	$\{q_0, q_1\}$	$\{q_0, q_2\}$
$\{q_0, q_2\}$	$\{q_0, q_1, q_3\}$	$\{q_0\}$

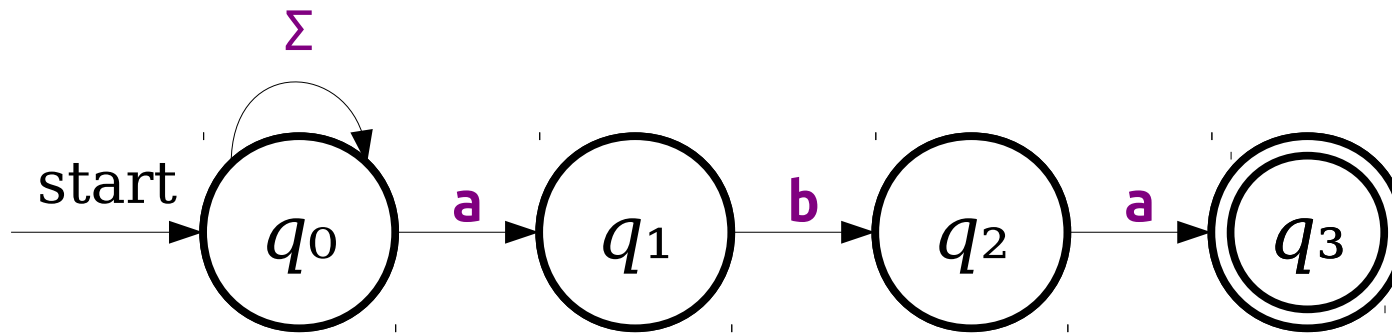

	<i>a</i>	<i>b</i>
$\{q_0\}$	$\{q_0, q_1\}$	$\{q_0\}$
$\{q_0, q_1\}$	$\{q_0, q_1\}$	$\{q_0, q_2\}$
$\{q_0, q_2\}$	$\{q_0, q_1, q_3\}$	$\{q_0\}$

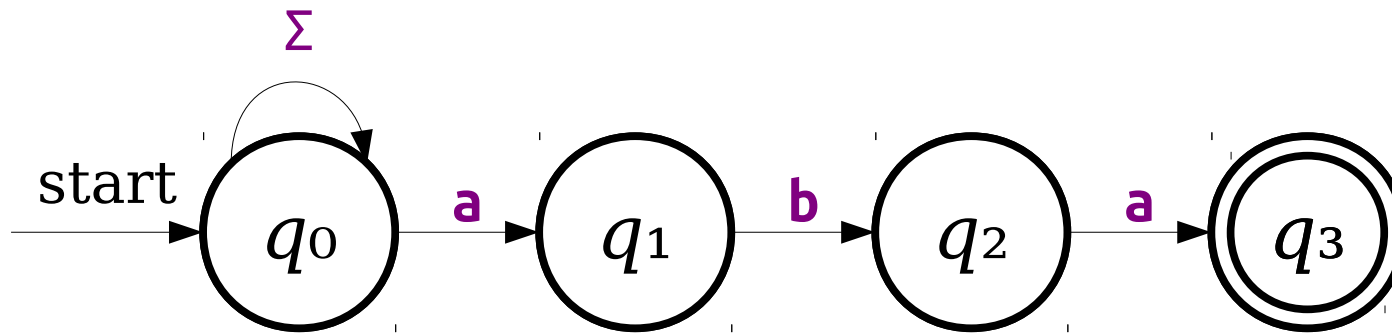

	<i>a</i>	<i>b</i>
$\{q_0\}$	$\{q_0, q_1\}$	$\{q_0\}$
$\{q_0, q_1\}$	$\{q_0, q_1\}$	$\{q_0, q_2\}$
$\{q_0, q_2\}$	$\{q_0, q_1, q_3\}$	$\{q_0\}$
$\{q_0, q_1, q_3\}$		

Fill in this row.

Answer at

<https://pollev.com/cs103>

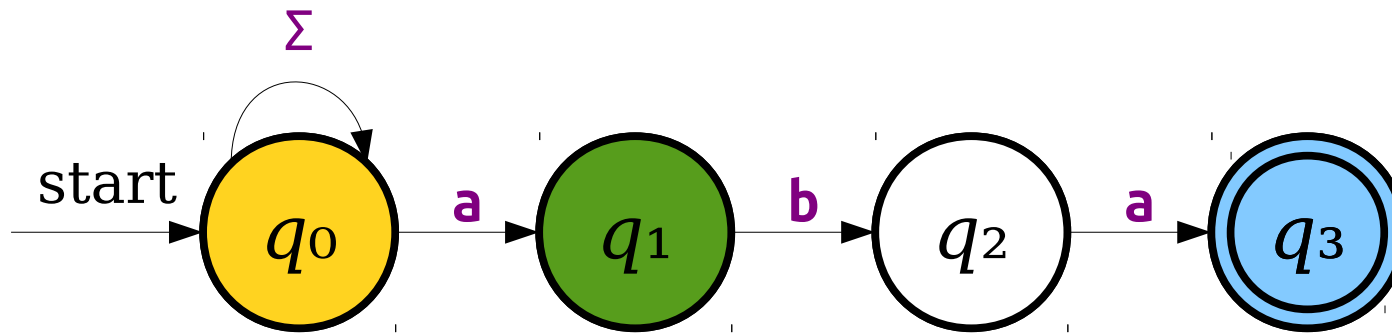

	$a$	$b$
$\{q_0\}$	$\{q_0, q_1\}$	$\{q_0\}$
$\{q_0, q_1\}$	$\{q_0, q_1\}$	$\{q_0, q_2\}$
$\{q_0, q_2\}$	$\{q_0, q_1, q_3\}$	$\{q_0\}$
$\{q_0, q_1, q_3\}$		

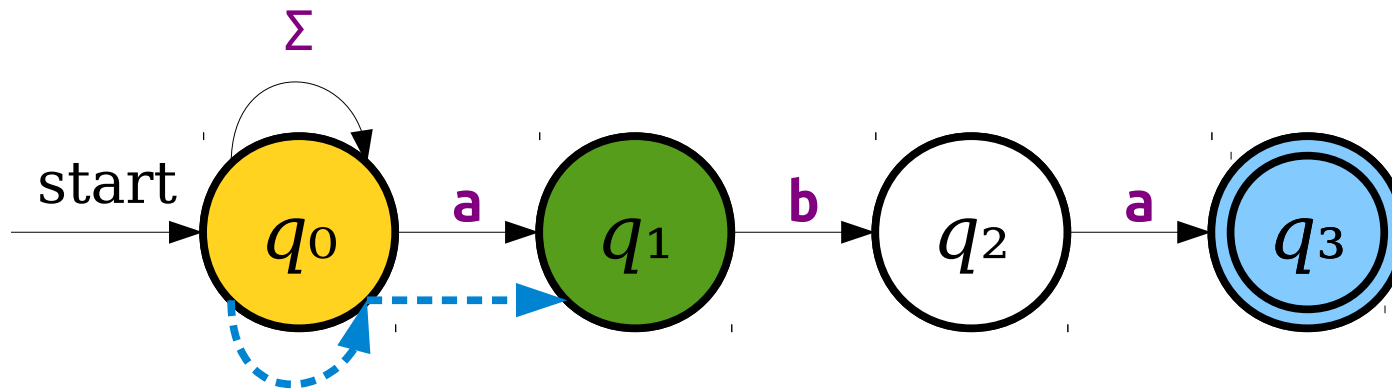

	$a$	$b$
$\{q_0\}$	$\{q_0, q_1\}$	$\{q_0\}$
$\{q_0, q_1\}$	$\{q_0, q_1\}$	$\{q_0, q_2\}$
$\{q_0, q_2\}$	$\{q_0, q_1, q_3\}$	$\{q_0\}$
$\{q_0, q_1, q_3\}$		

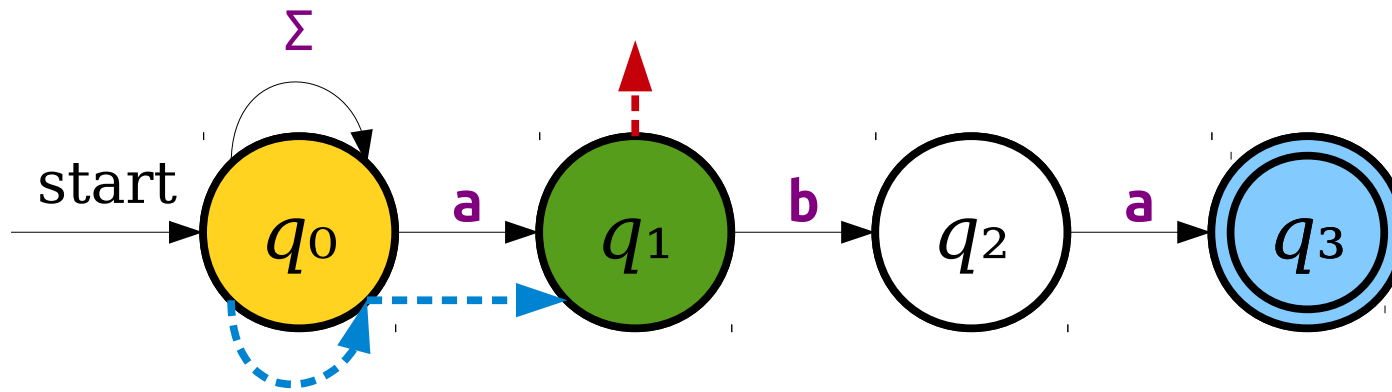

	<i>a</i>	<i>b</i>
$\{q_0\}$	$\{q_0, q_1\}$	$\{q_0\}$
$\{q_0, q_1\}$	$\{q_0, q_1\}$	$\{q_0, q_2\}$
$\{q_0, q_2\}$	$\{q_0, q_1, q_3\}$	$\{q_0\}$
$\{q_0, q_1, q_3\}$		

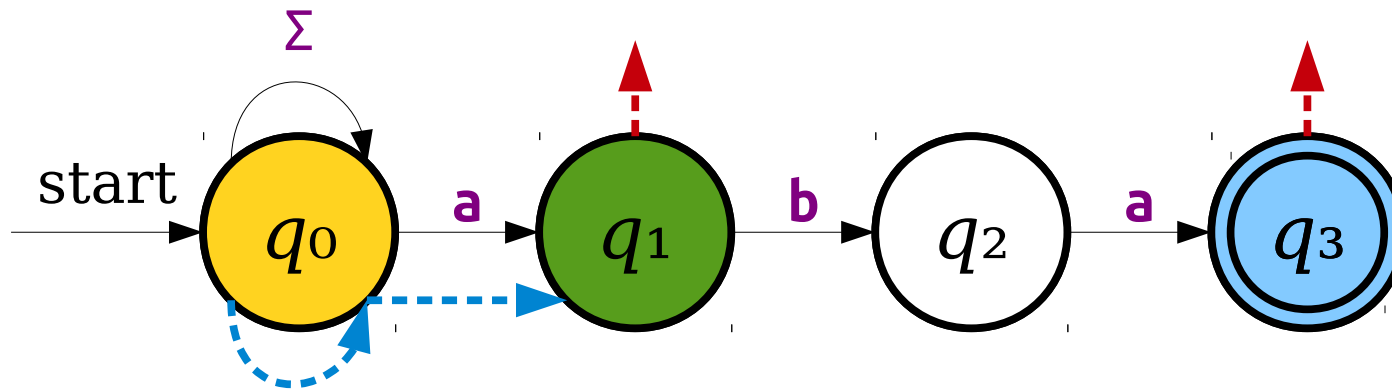

	<i>a</i>	<i>b</i>
$\{q_0\}$	$\{q_0, q_1\}$	$\{q_0\}$
$\{q_0, q_1\}$	$\{q_0, q_1\}$	$\{q_0, q_2\}$
$\{q_0, q_2\}$	$\{q_0, q_1, q_3\}$	$\{q_0\}$
$\{q_0, q_1, q_3\}$		

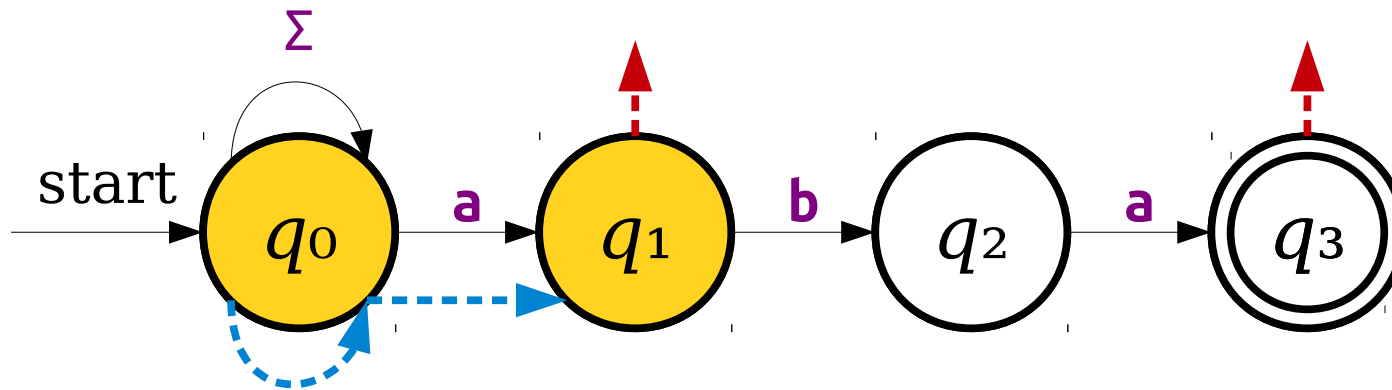

	$a$	$b$
$\{q_0\}$	$\{q_0, q_1\}$	$\{q_0\}$
$\{q_0, q_1\}$	$\{q_0, q_1\}$	$\{q_0, q_2\}$
$\{q_0, q_2\}$	$\{q_0, q_1, q_3\}$	$\{q_0\}$
$\{q_0, q_1, q_3\}$		

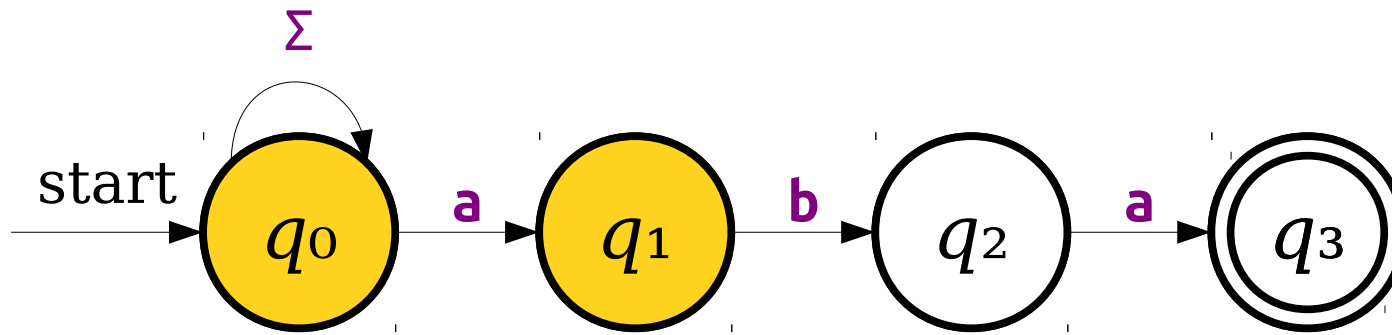

	$a$	$b$
$\{q_0\}$	$\{q_0, q_1\}$	$\{q_0\}$
$\{q_0, q_1\}$	$\{q_0, q_1\}$	$\{q_0, q_2\}$
$\{q_0, q_2\}$	$\{q_0, q_1, q_3\}$	$\{q_0\}$
$\{q_0, q_1, q_3\}$	$\{q_0, q_1\}$	

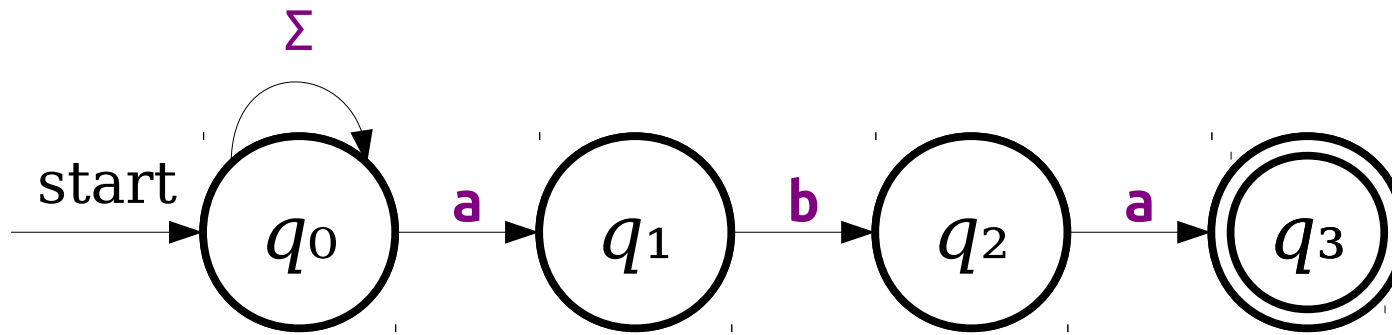

	$a$	$b$
$\{q_0\}$	$\{q_0, q_1\}$	$\{q_0\}$
$\{q_0, q_1\}$	$\{q_0, q_1\}$	$\{q_0, q_2\}$
$\{q_0, q_2\}$	$\{q_0, q_1, q_3\}$	$\{q_0\}$
$\{q_0, q_1, q_3\}$	$\{q_0, q_1\}$	

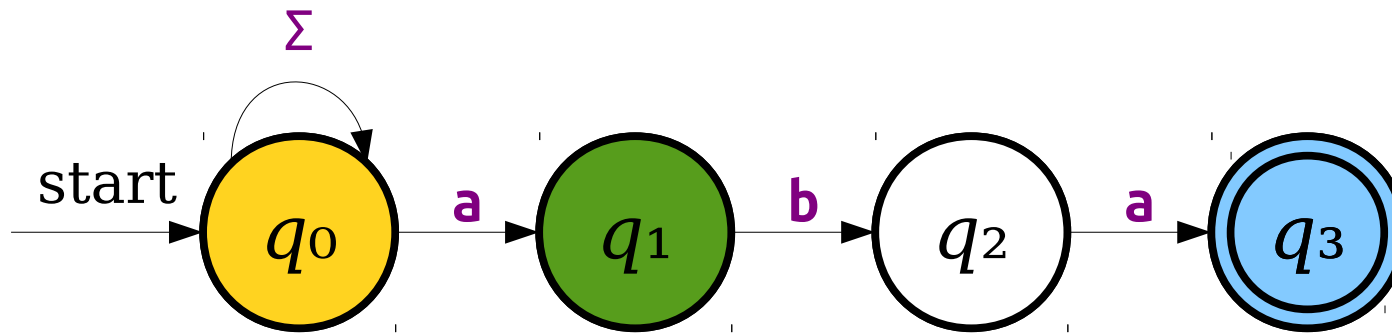

	$a$	$b$
$\{q_0\}$	$\{q_0, q_1\}$	$\{q_0\}$
$\{q_0, q_1\}$	$\{q_0, q_1\}$	$\{q_0, q_2\}$
$\{q_0, q_2\}$	$\{q_0, q_1, q_3\}$	$\{q_0\}$
$\{q_0, q_1, q_3\}$	$\{q_0, q_1\}$	

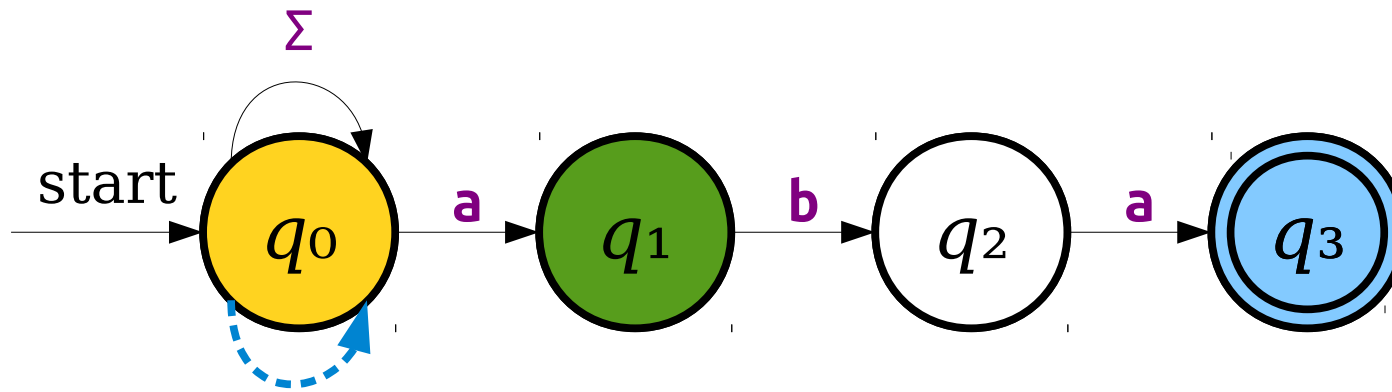

	$a$	$b$
$\{q_0\}$	$\{q_0, q_1\}$	$\{q_0\}$
$\{q_0, q_1\}$	$\{q_0, q_1\}$	$\{q_0, q_2\}$
$\{q_0, q_2\}$	$\{q_0, q_1, q_3\}$	$\{q_0\}$
$\{q_0, q_1, q_3\}$	$\{q_0, q_1\}$	

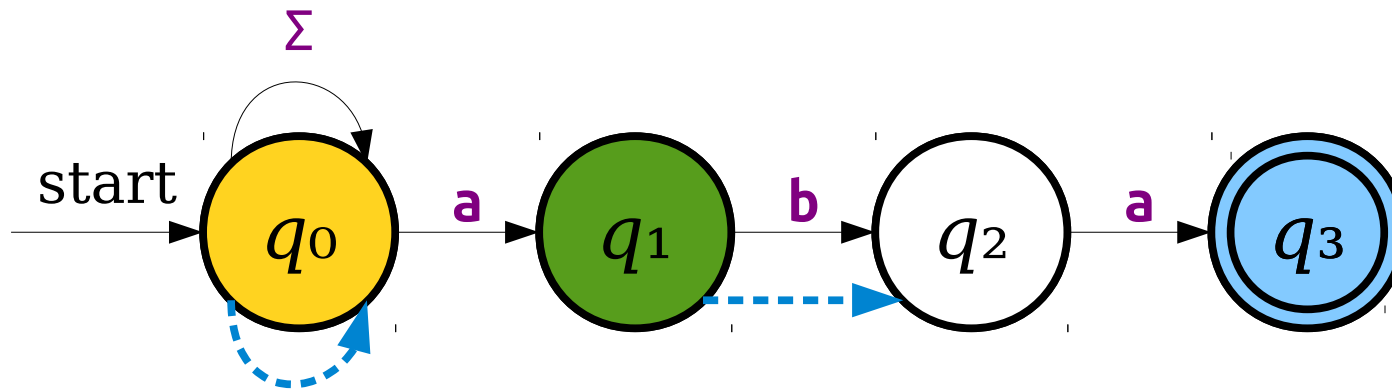

	$a$	$b$
$\{q_0\}$	$\{q_0, q_1\}$	$\{q_0\}$
$\{q_0, q_1\}$	$\{q_0, q_1\}$	$\{q_0, q_2\}$
$\{q_0, q_2\}$	$\{q_0, q_1, q_3\}$	$\{q_0\}$
$\{q_0, q_1, q_3\}$	$\{q_0, q_1\}$	

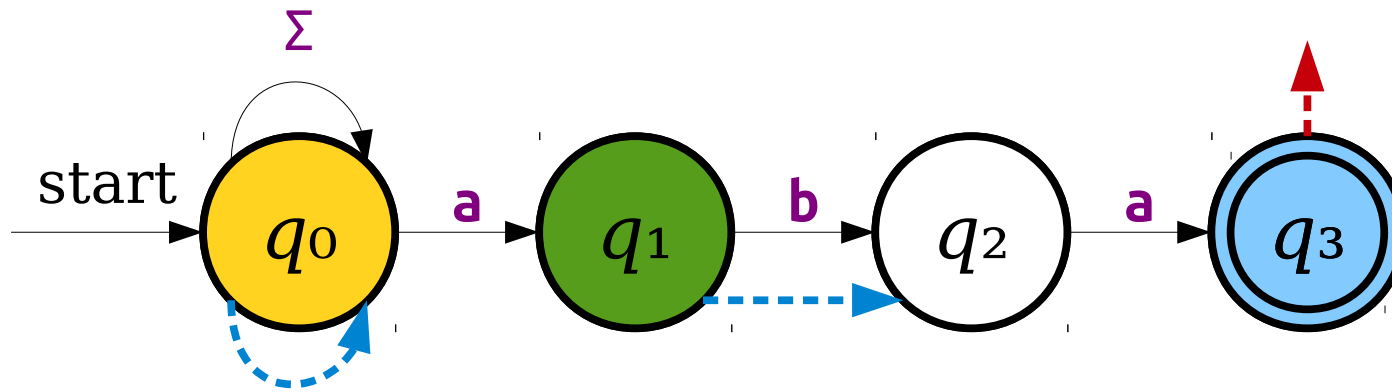

	$a$	$b$
$\{q_0\}$	$\{q_0, q_1\}$	$\{q_0\}$
$\{q_0, q_1\}$	$\{q_0, q_1\}$	$\{q_0, q_2\}$
$\{q_0, q_2\}$	$\{q_0, q_1, q_3\}$	$\{q_0\}$
$\{q_0, q_1, q_3\}$	$\{q_0, q_1\}$	

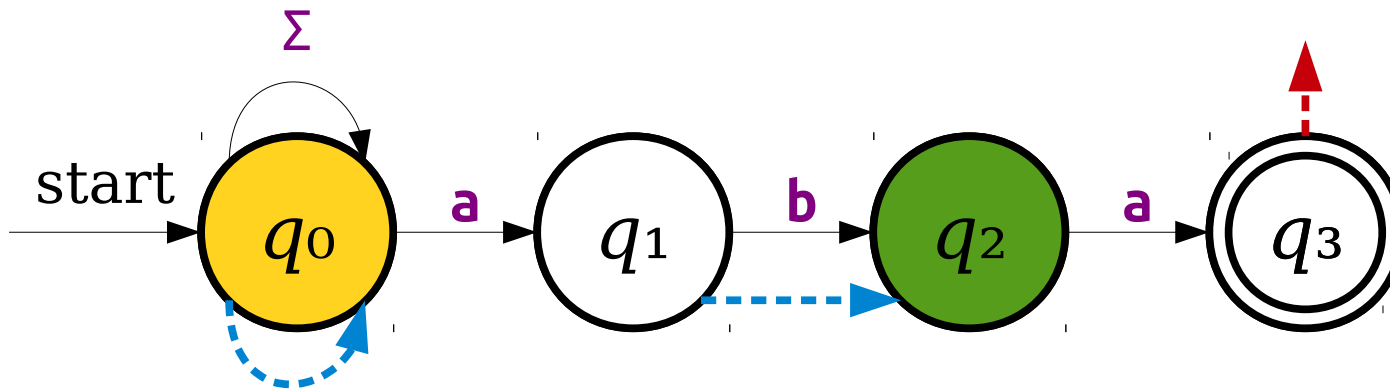

	$a$	$b$
$\{q_0\}$	$\{q_0, q_1\}$	$\{q_0\}$
$\{q_0, q_1\}$	$\{q_0, q_1\}$	$\{q_0, q_2\}$
$\{q_0, q_2\}$	$\{q_0, q_1, q_3\}$	$\{q_0\}$
$\{q_0, q_1, q_3\}$	$\{q_0, q_1\}$	

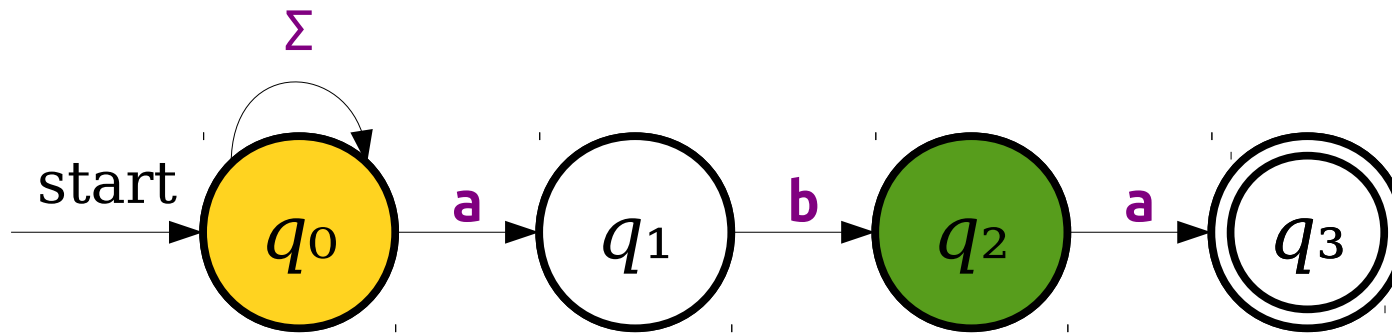

	$a$	$b$
$\{q_0\}$	$\{q_0, q_1\}$	$\{q_0\}$
$\{q_0, q_1\}$	$\{q_0, q_1\}$	$\{q_0, q_2\}$
$\{q_0, q_2\}$	$\{q_0, q_1, q_3\}$	$\{q_0\}$
$\{q_0, q_1, q_3\}$	$\{q_0, q_1\}$	$\{q_0, q_2\}$

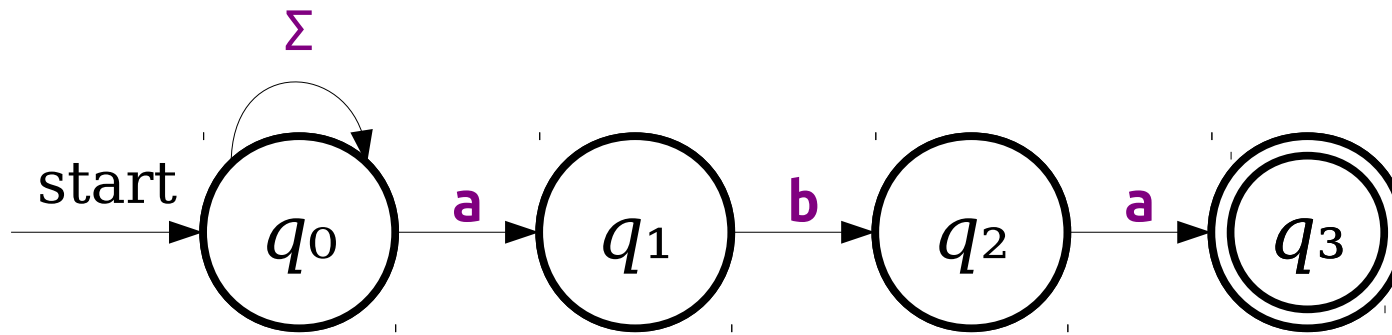

	$a$	$b$
$\{q_0\}$	$\{q_0, q_1\}$	$\{q_0\}$
$\{q_0, q_1\}$	$\{q_0, q_1\}$	$\{q_0, q_2\}$
$\{q_0, q_2\}$	$\{q_0, q_1, q_3\}$	$\{q_0\}$
$\{q_0, q_1, q_3\}$	$\{q_0, q_1\}$	$\{q_0, q_2\}$

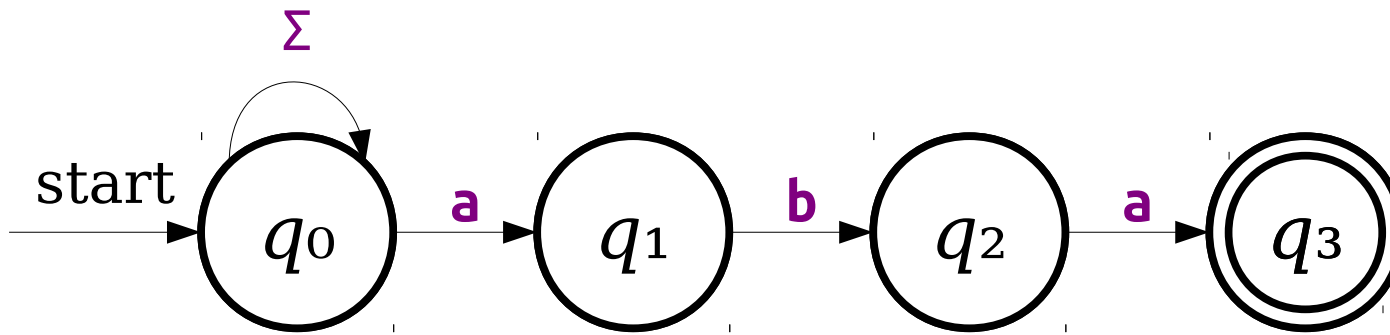

	<i>a</i>	<i>b</i>
$\{q_0\}$	$\{q_0, q_1\}$	$\{q_0\}$
$\{q_0, q_1\}$	$\{q_0, q_1\}$	$\{q_0, q_2\}$
$\{q_0, q_2\}$	$\{q_0, q_1, q_3\}$	$\{q_0\}$
$\{q_0, q_1, q_3\}$	$\{q_0, q_1\}$	$\{q_0, q_2\}$

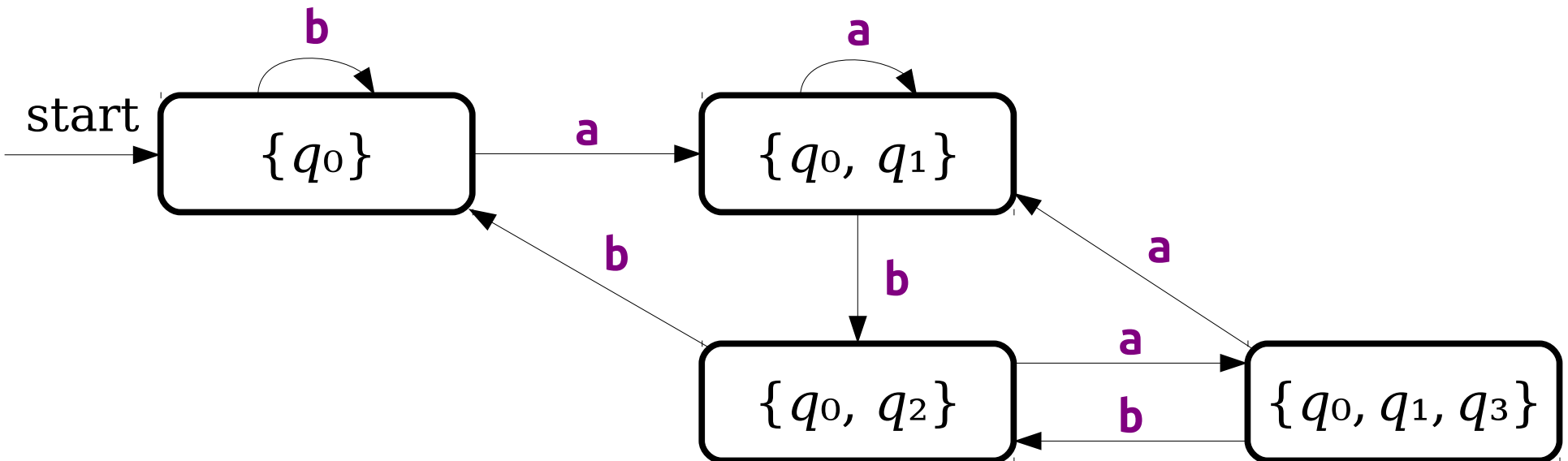

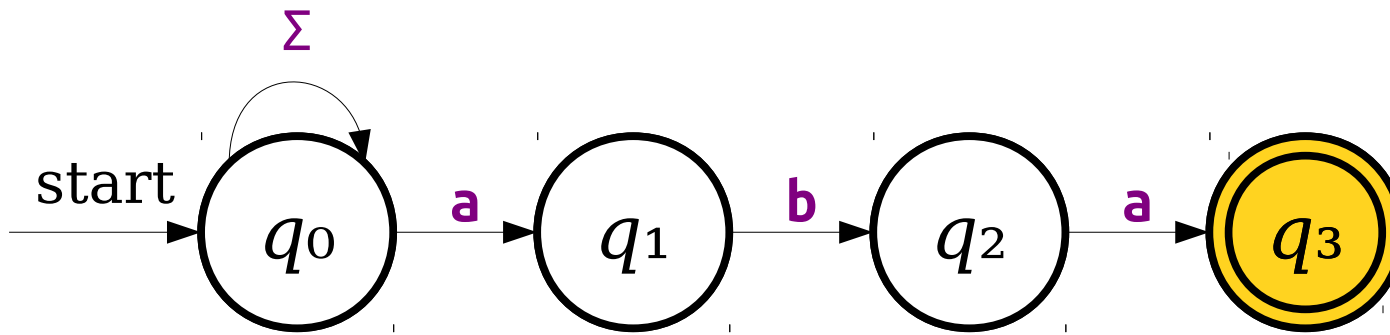

	<i>a</i>	<i>b</i>
$\{q_0\}$	$\{q_0, q_1\}$	$\{q_0\}$
$\{q_0, q_1\}$	$\{q_0, q_1\}$	$\{q_0, q_2\}$
$\{q_0, q_2\}$	$\{q_0, q_1, q_3\}$	$\{q_0\}$
$\{q_0, q_1, q_3\}$	$\{q_0, q_1\}$	$\{q_0, q_2\}$

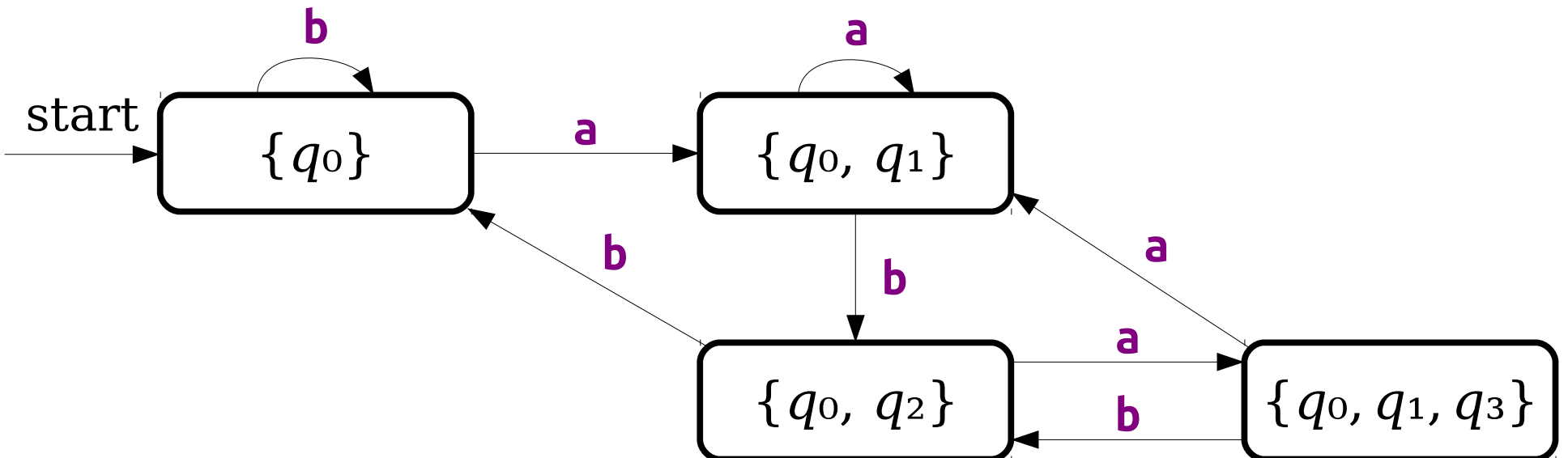

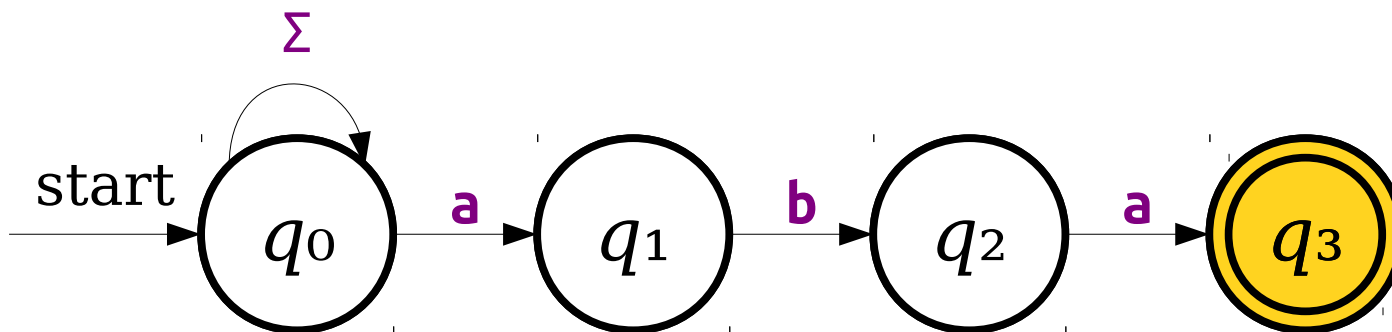

	<i>a</i>	<i>b</i>
$\{q_0\}$	$\{q_0, q_1\}$	$\{q_0\}$
$\{q_0, q_1\}$	$\{q_0, q_1\}$	$\{q_0, q_2\}$
$\{q_0, q_2\}$	$\{q_0, q_1, q_3\}$	$\{q_0\}$
$*\{q_0, q_1, q_3\}$	$\{q_0, q_1\}$	$\{q_0, q_2\}$

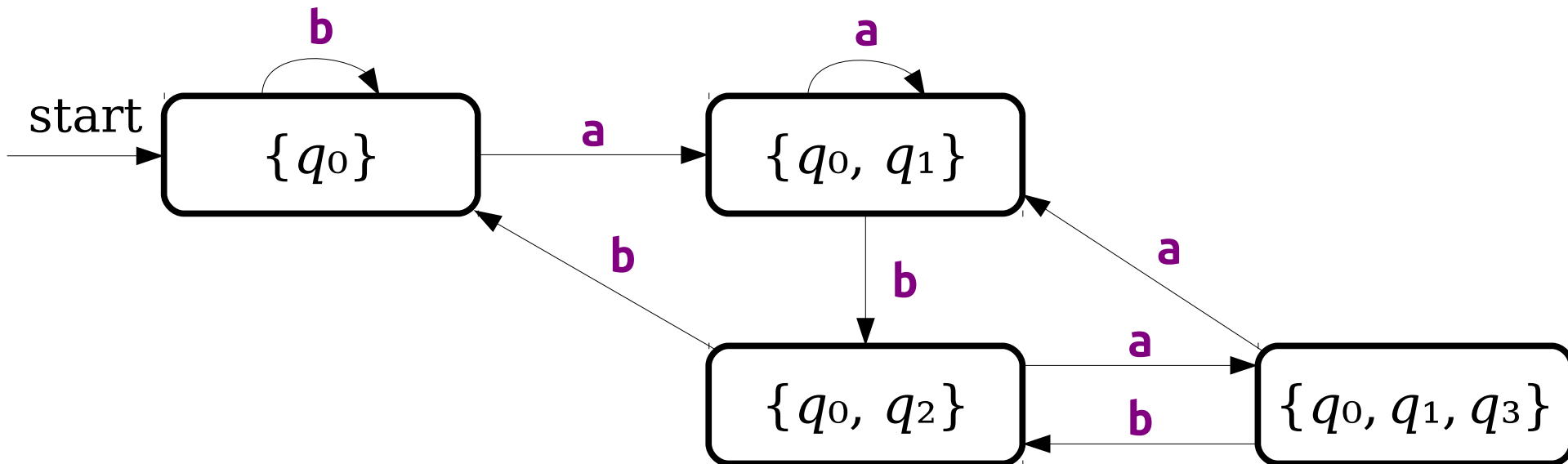

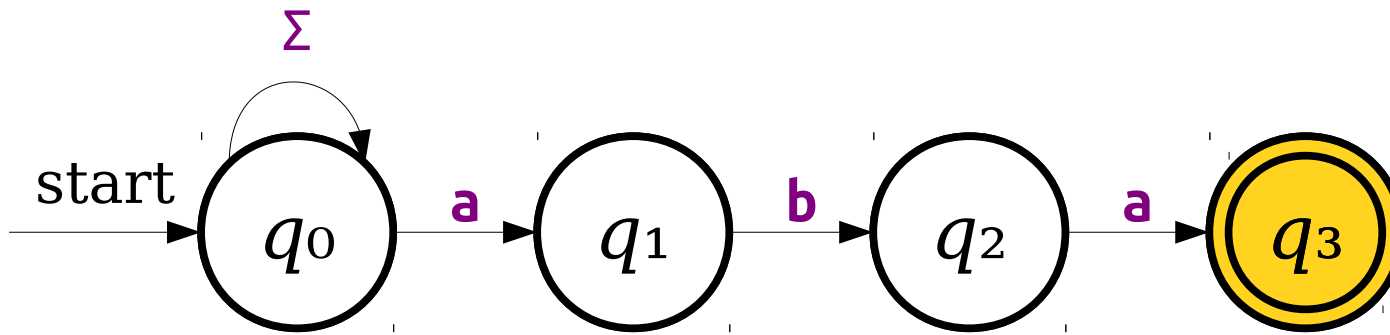

	<i>a</i>	<i>b</i>
$\{q_0\}$	$\{q_0, q_1\}$	$\{q_0\}$
$\{q_0, q_1\}$	$\{q_0, q_1\}$	$\{q_0, q_2\}$
$\{q_0, q_2\}$	$\{q_0, q_1, q_3\}$	$\{q_0\}$
$*\{q_0, q_1, q_3\}$	$\{q_0, q_1\}$	$\{q_0, q_2\}$

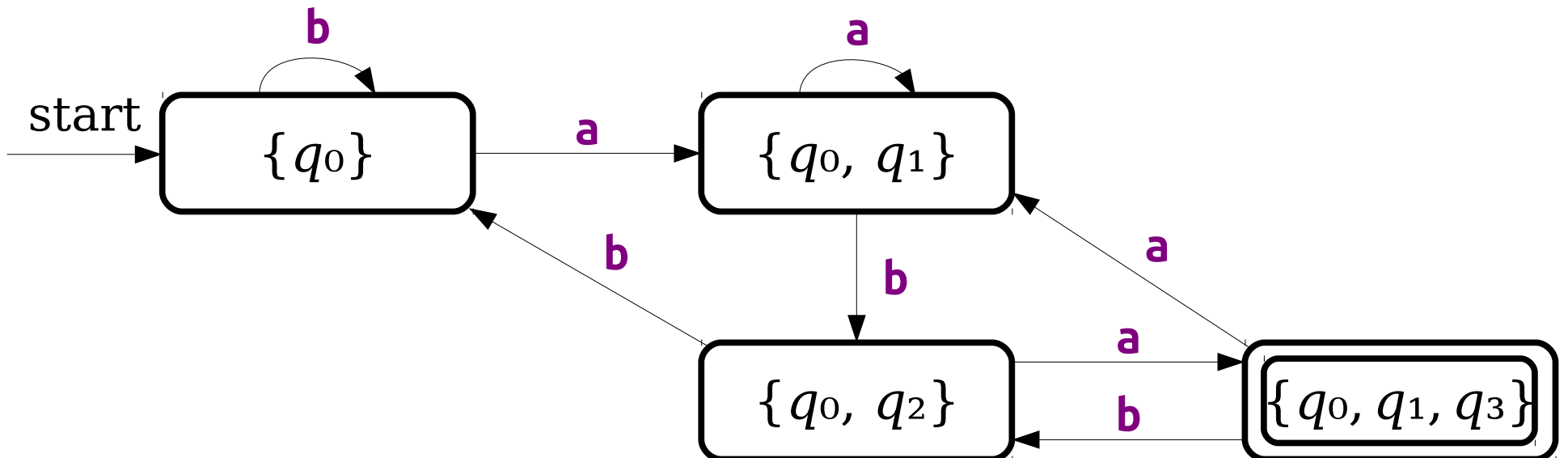

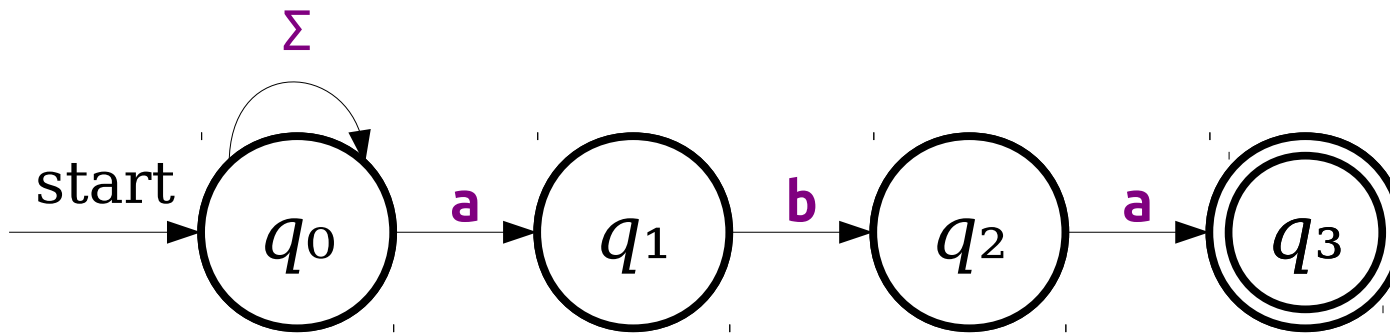

	<i>a</i>	<i>b</i>
$\{q_0\}$	$\{q_0, q_1\}$	$\{q_0\}$
$\{q_0, q_1\}$	$\{q_0, q_1\}$	$\{q_0, q_2\}$
$\{q_0, q_2\}$	$\{q_0, q_1, q_3\}$	$\{q_0\}$
$*\{q_0, q_1, q_3\}$	$\{q_0, q_1\}$	$\{q_0, q_2\}$

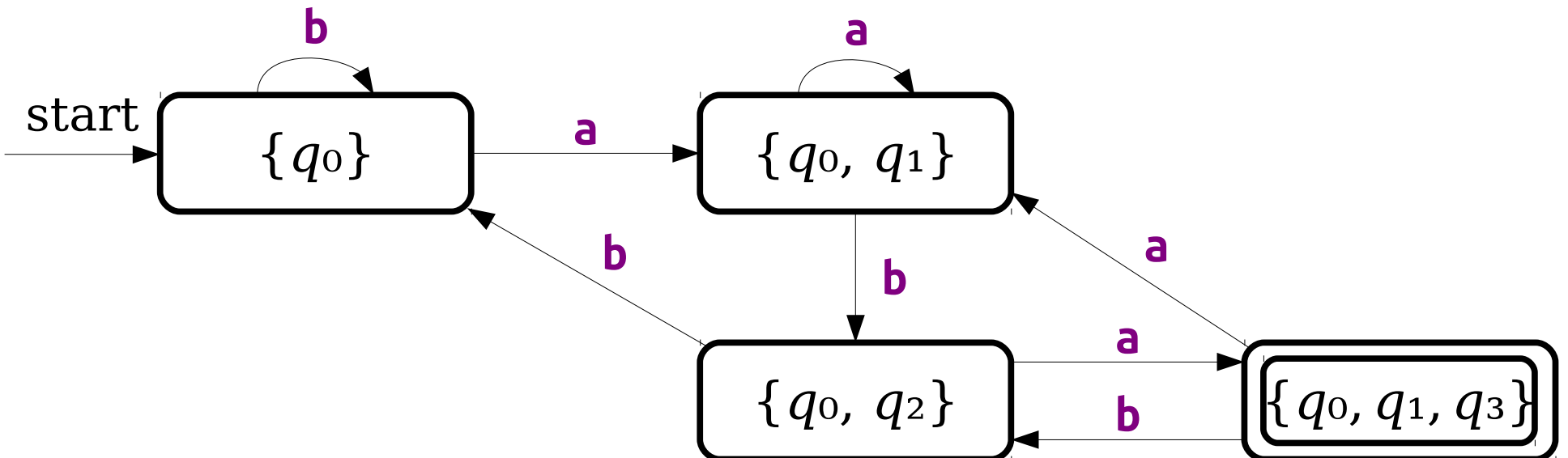

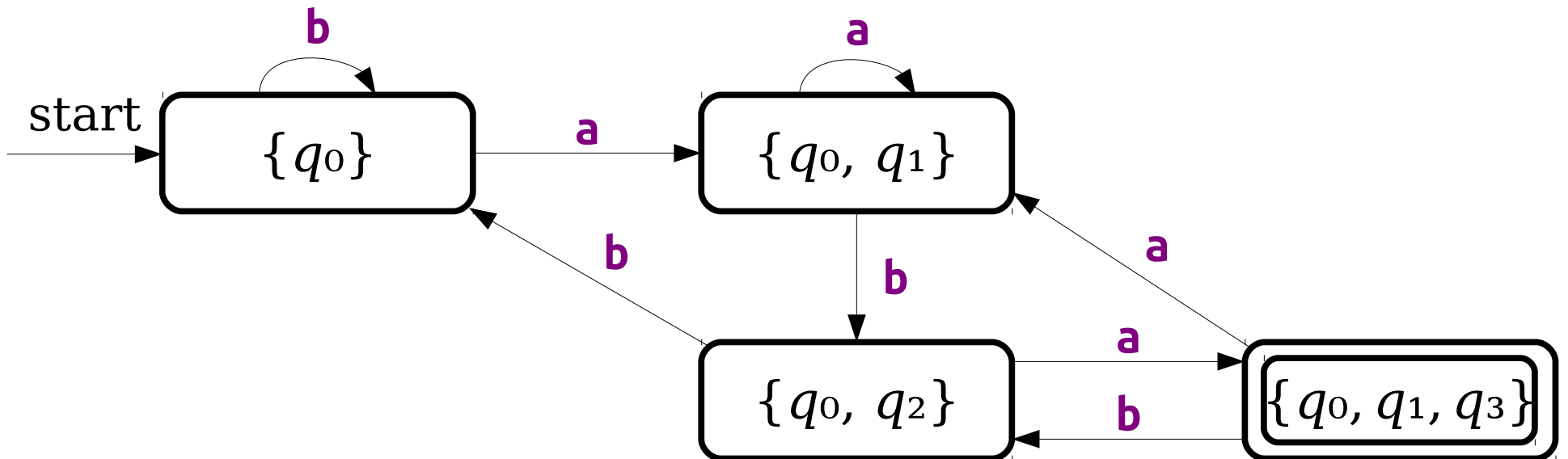
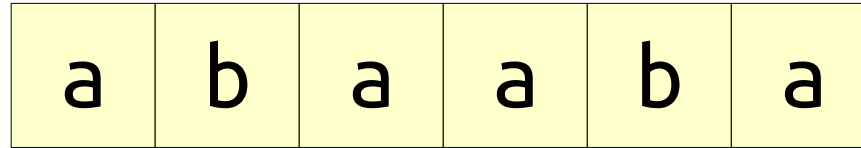
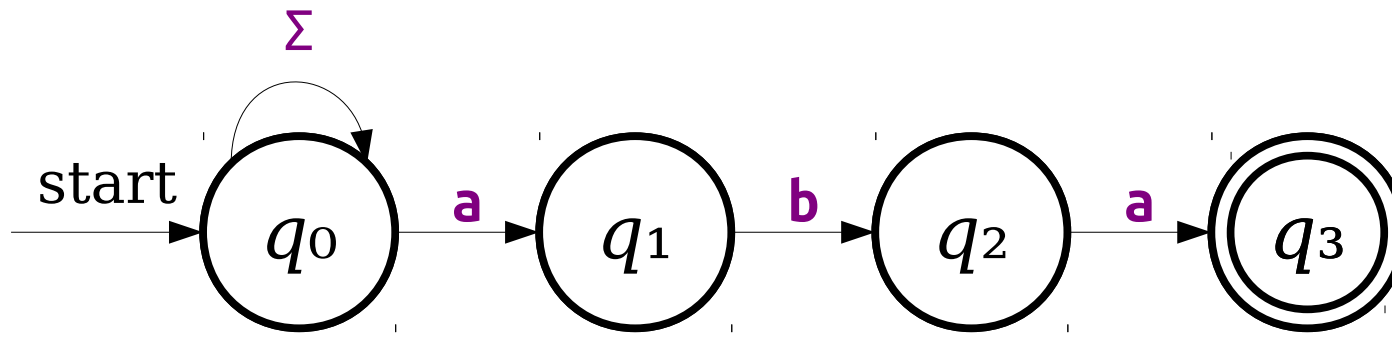

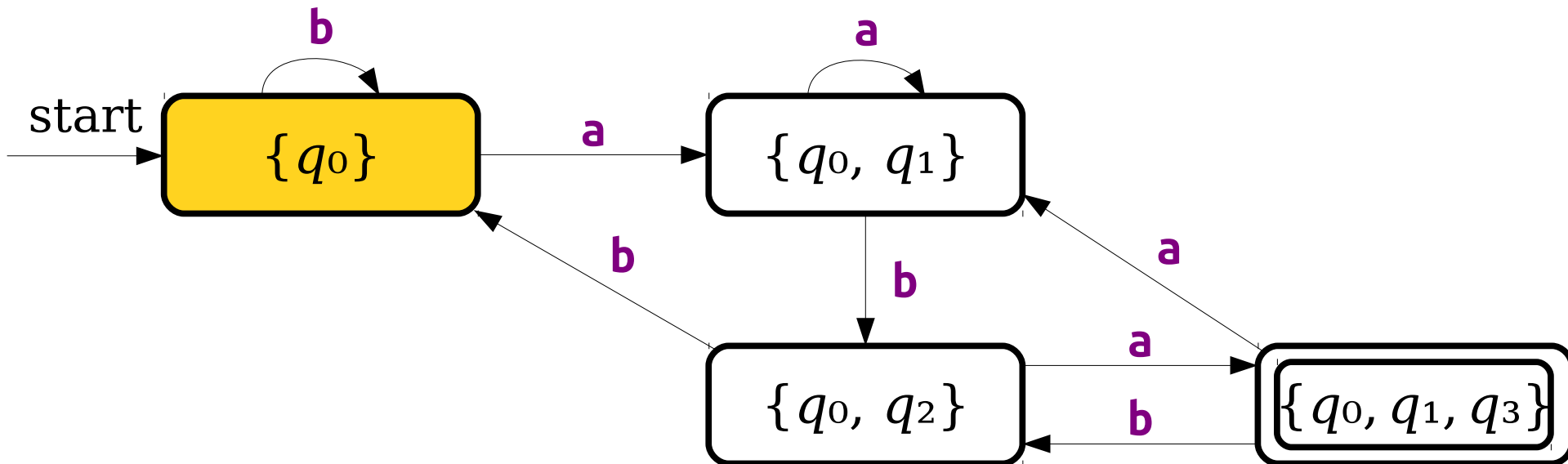
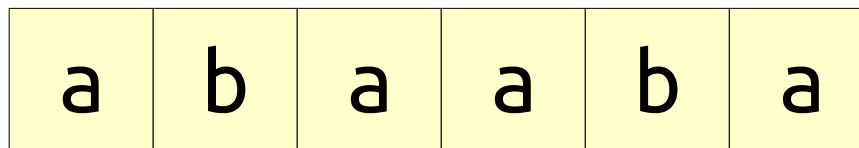
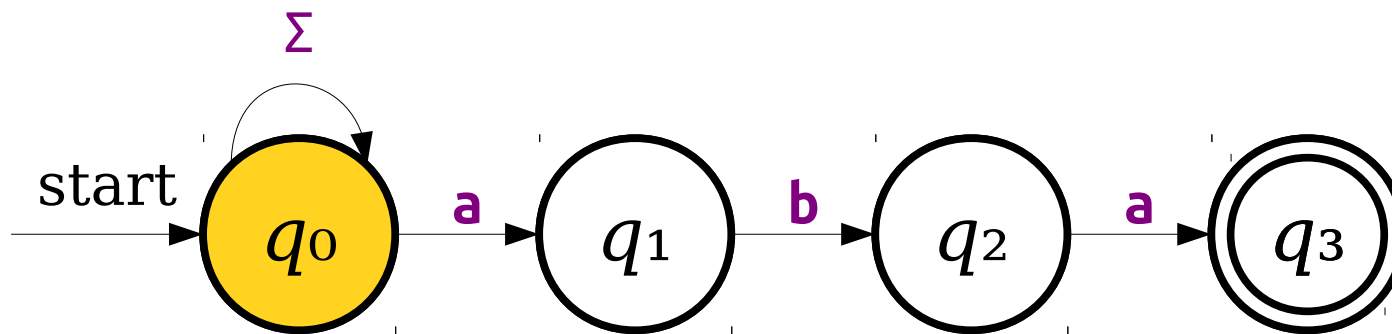

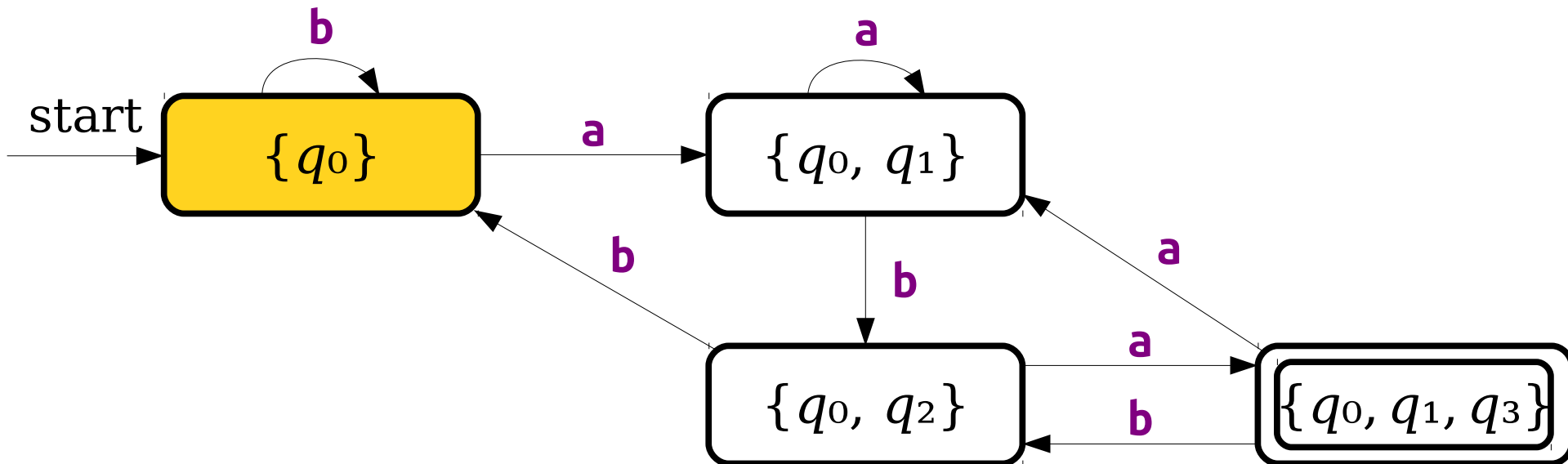
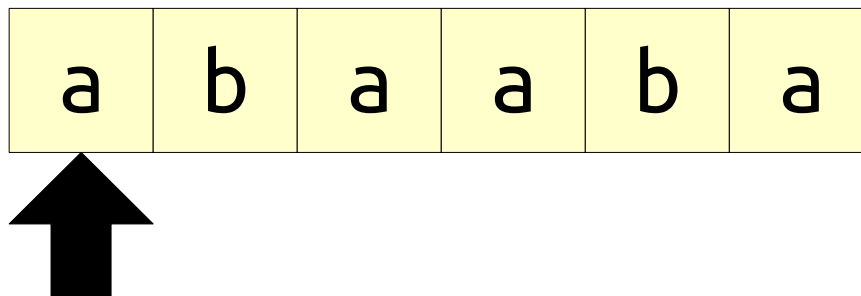
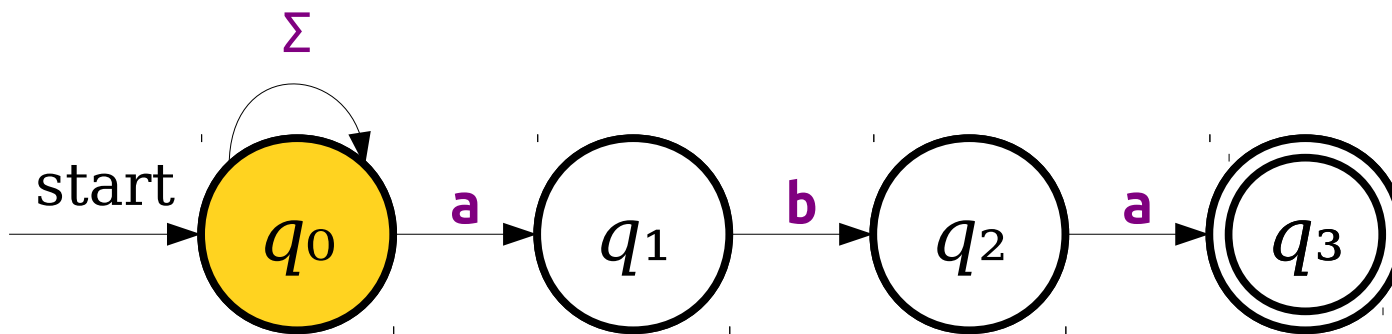

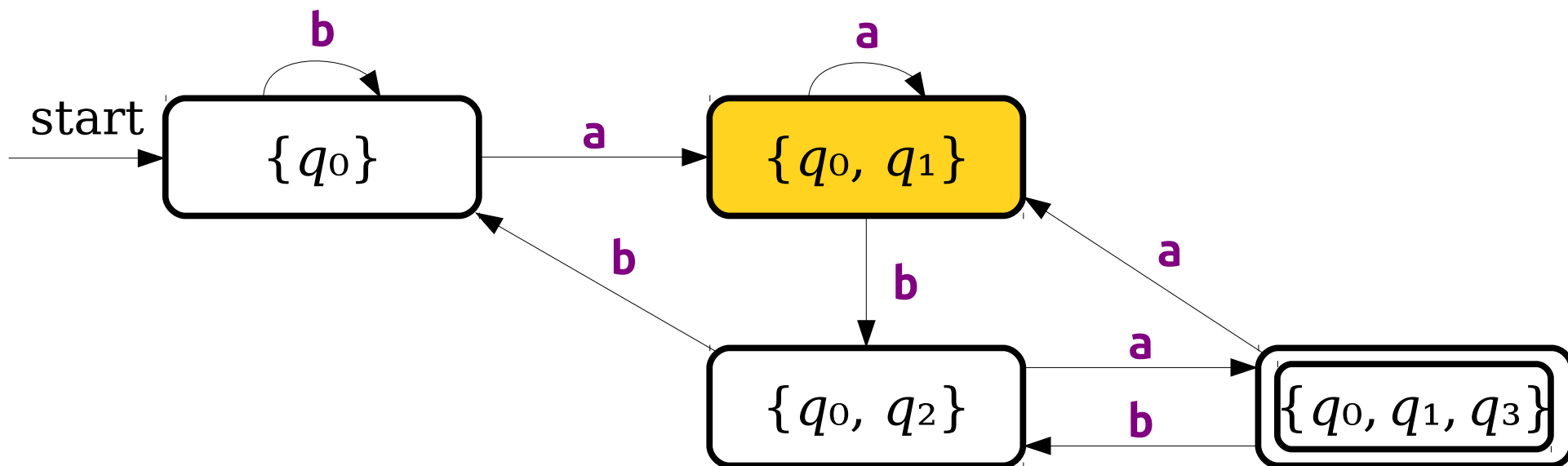
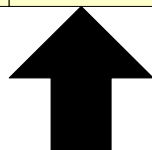
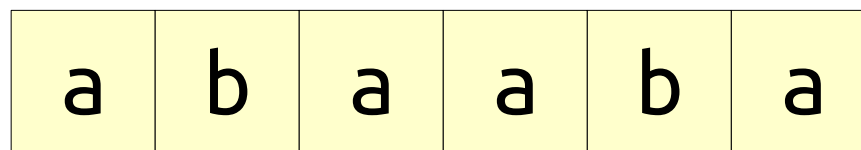
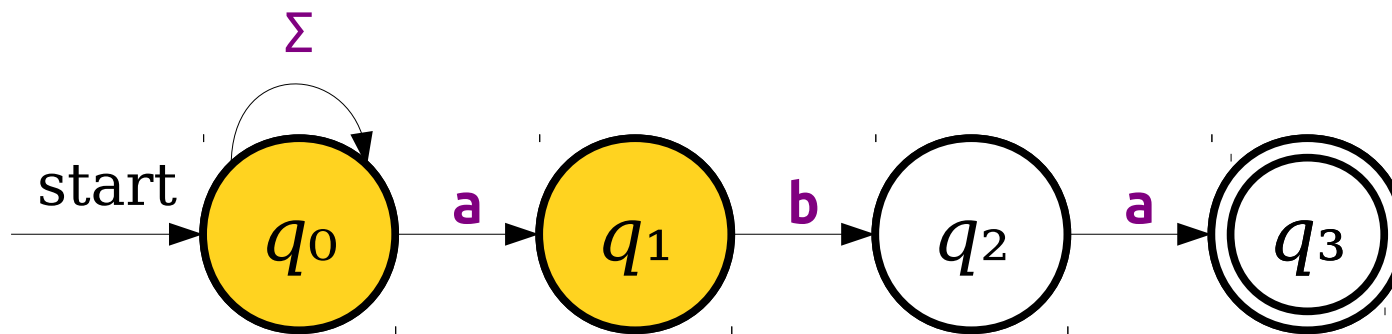

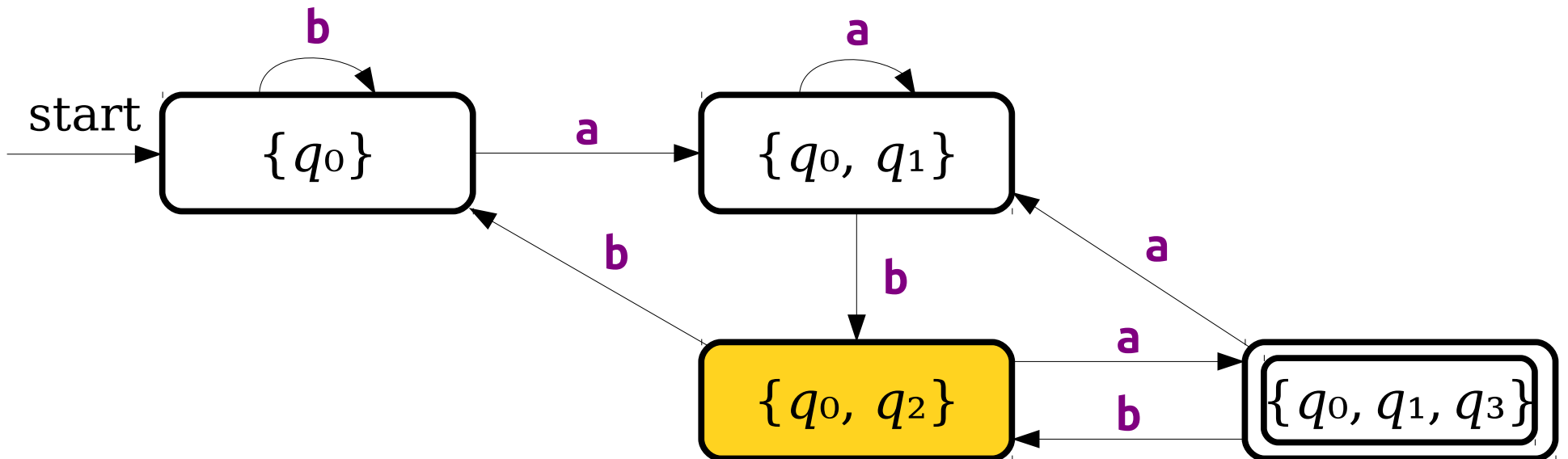
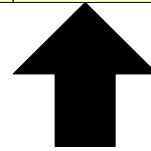
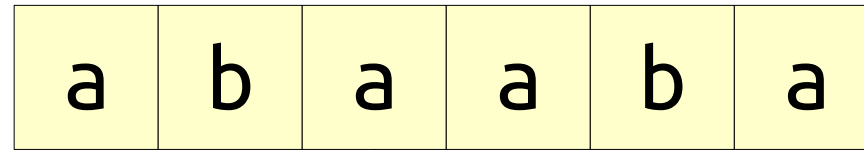
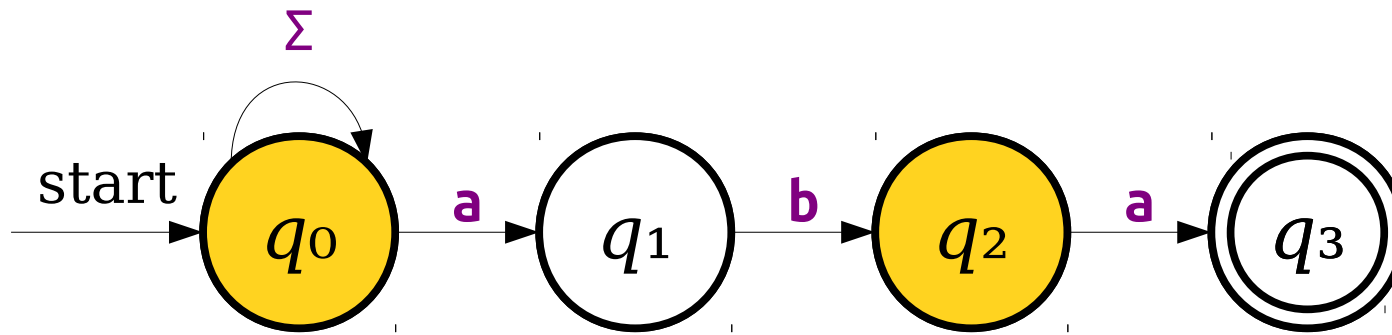

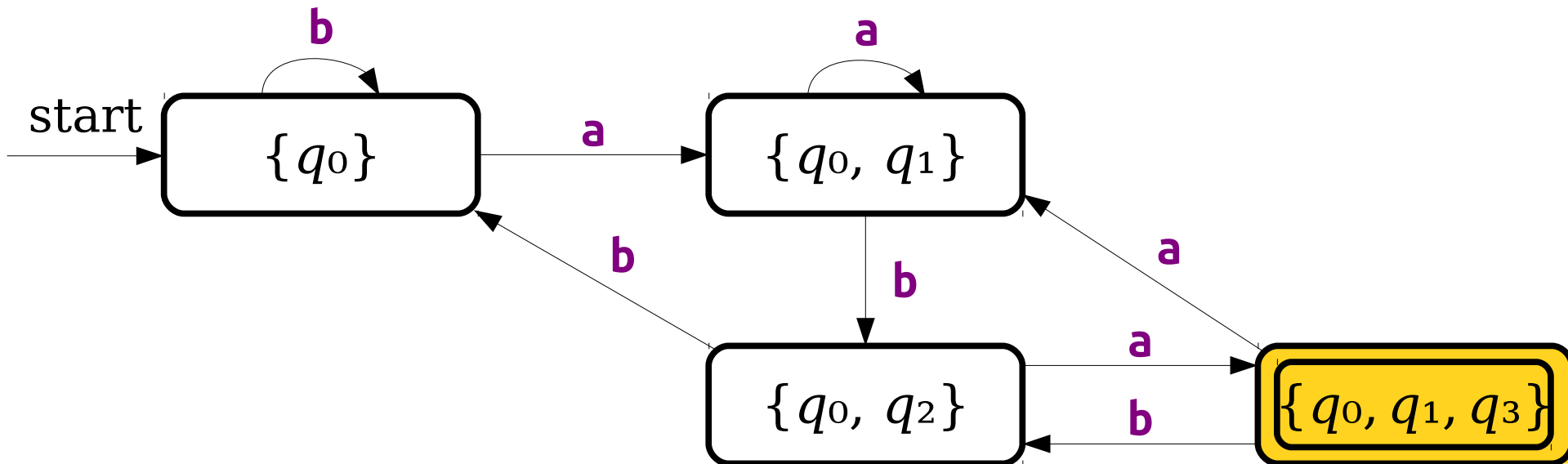
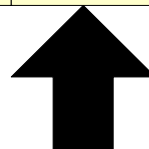
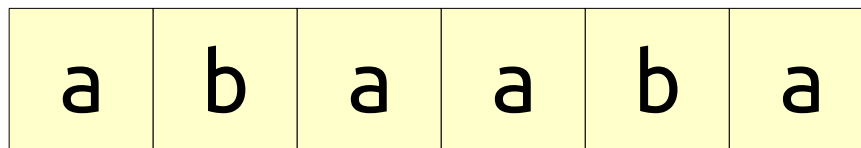
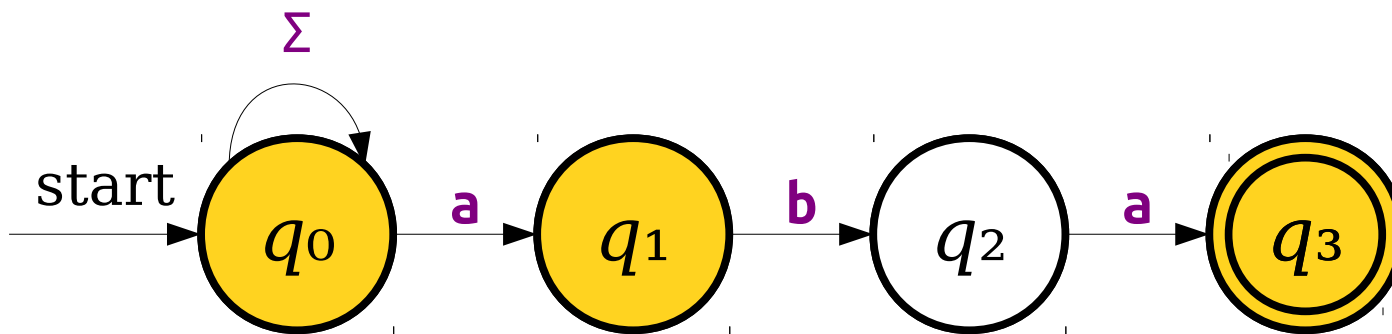

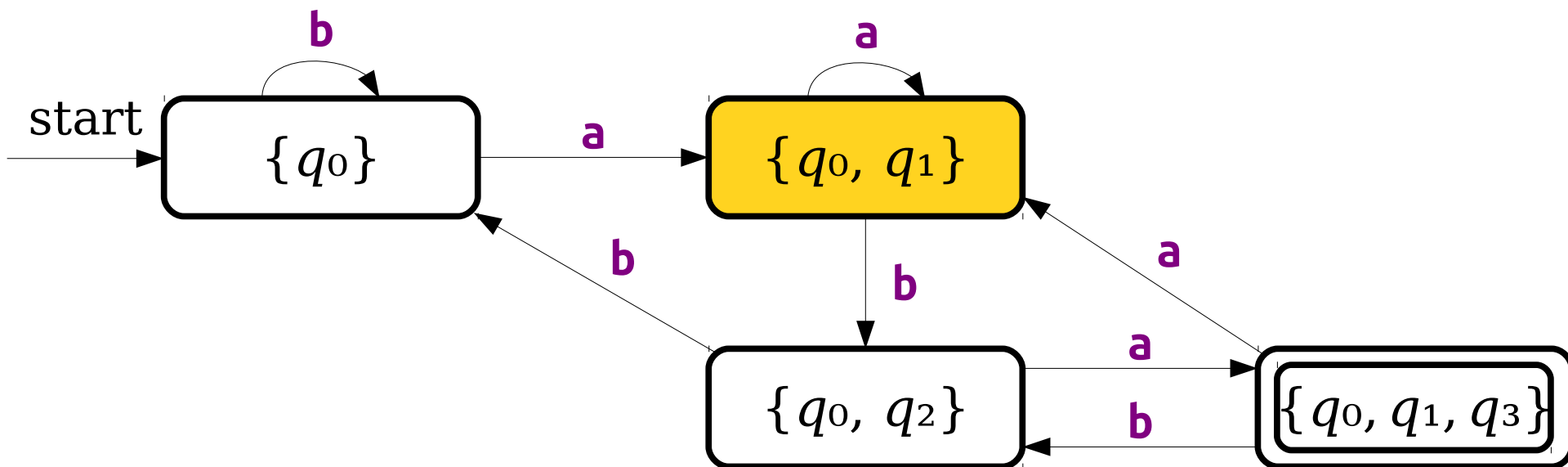
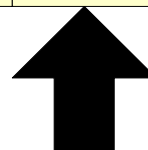
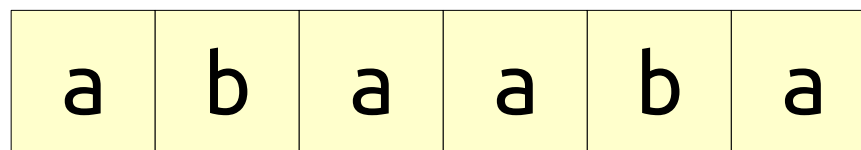
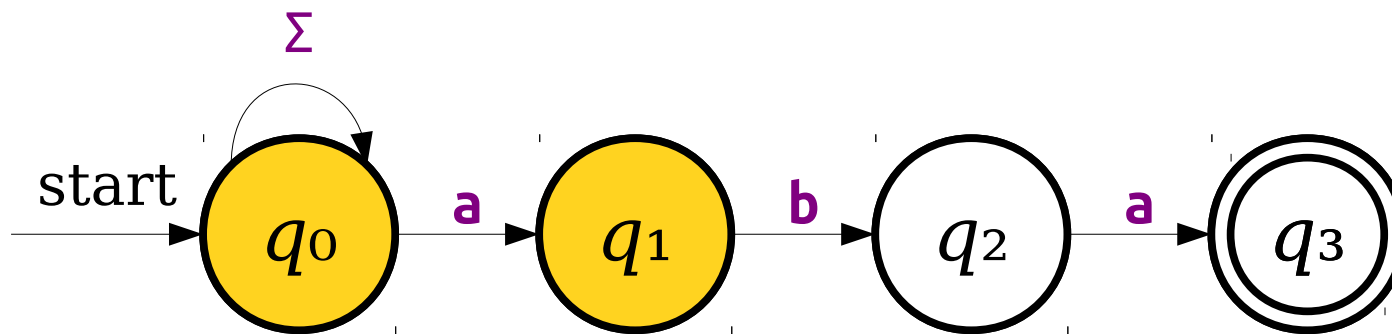

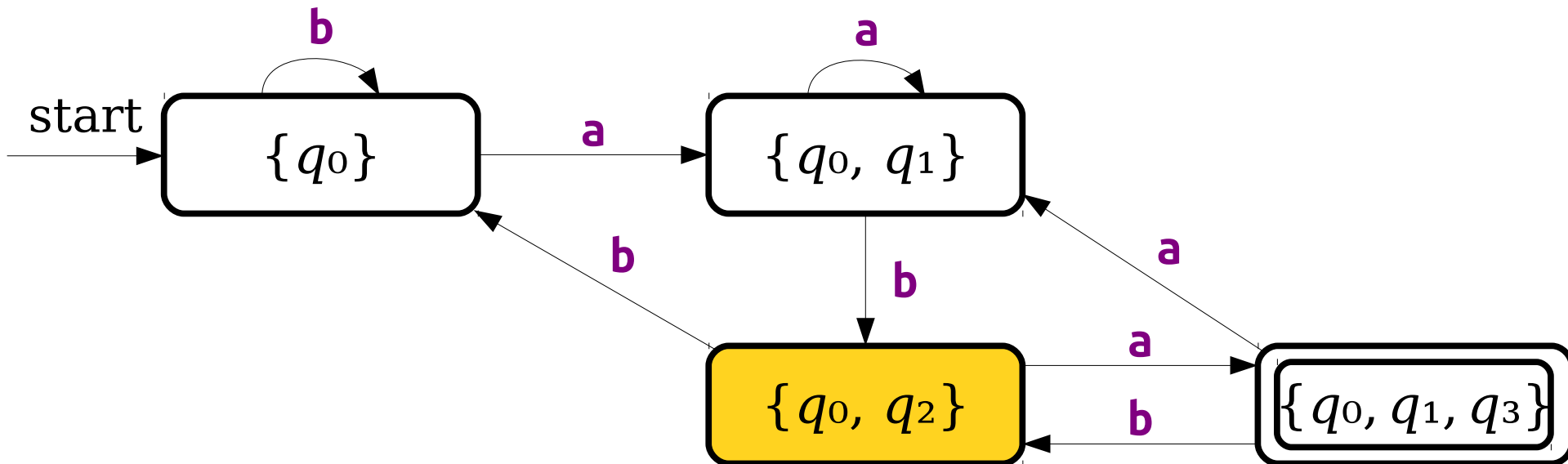
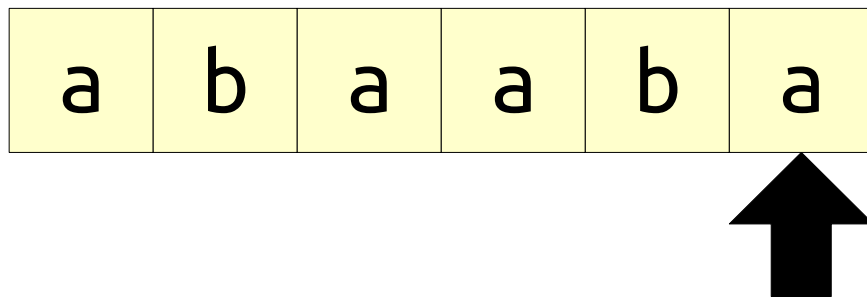
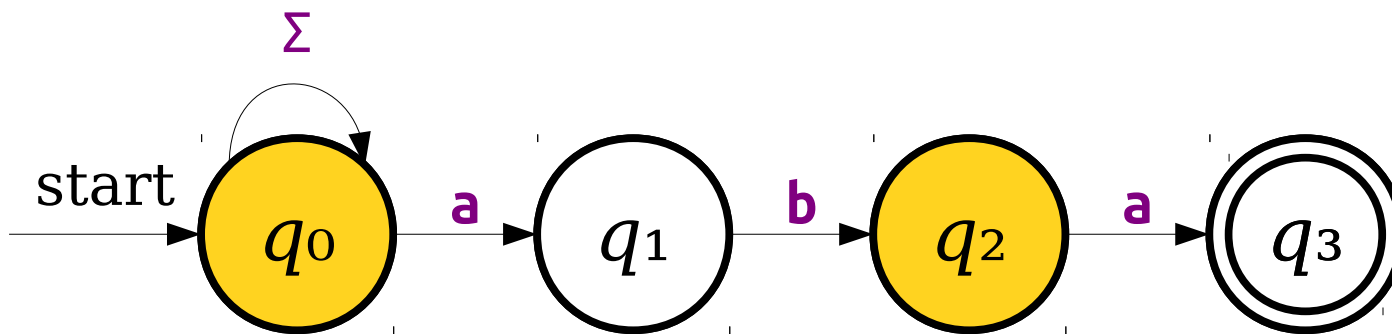

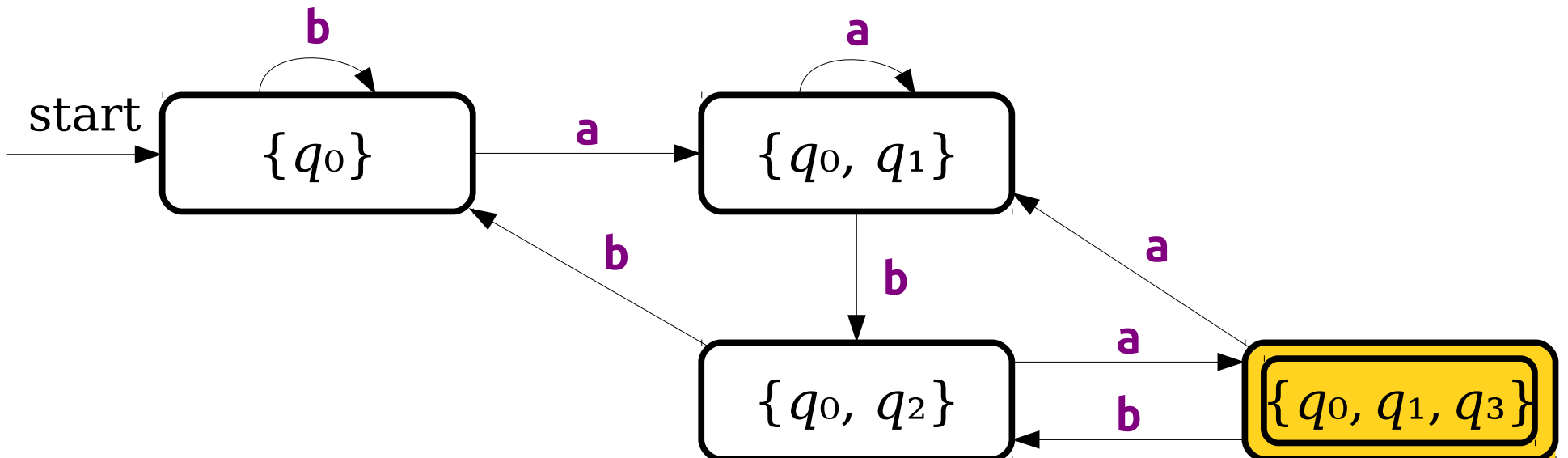
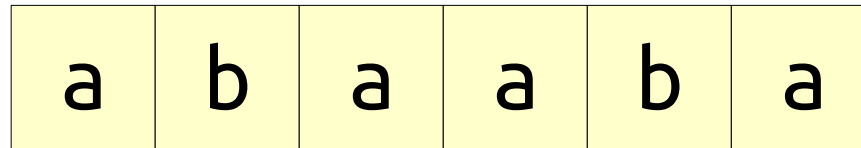
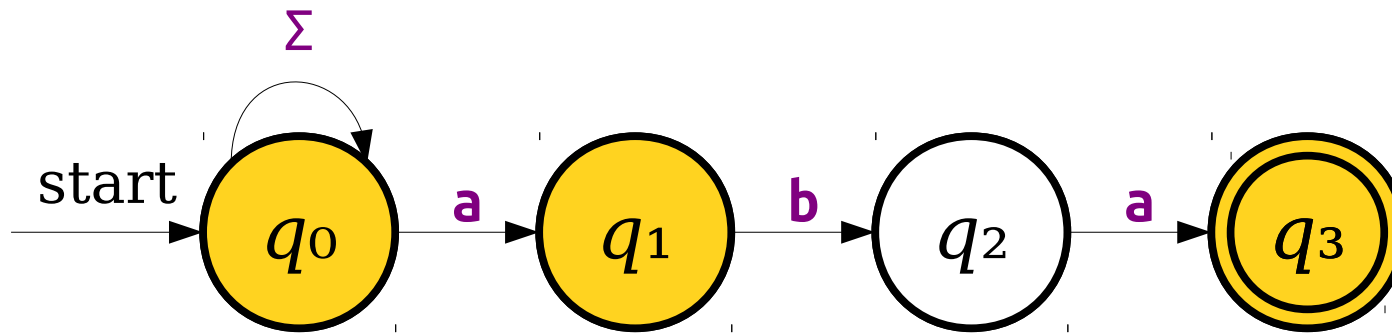

# The Subset Construction

- This procedure for turning an NFA for a language  $L$  into a DFA for a language  $L$  is called the **subset construction**.
  - It's sometimes called the **powerset construction**; it's different names for the same thing!
- Intuitively:
  - Each state in the DFA corresponds to a set of states from the NFA.
  - Each transition in the DFA corresponds to what transitions would be taken in the NFA when using the massive parallel intuition.
  - The accepting states in the DFA correspond to which sets of states would be considered accepting in the NFA when using the massive parallel intuition.
- There's an online **Guide to the Subset Construction** with a more elaborate example involving  $\epsilon$ -transitions and cases where the NFA dies; check that for more details.

# The Subset Construction

- In converting an NFA to a DFA, the DFA's states correspond to sets of NFA states.
- **Useful fact:**  $|\wp(S)| = 2^{|S|}$  for any finite set  $S$ .
- In the worst-case, the construction can result in a DFA that is *exponentially larger* than the original NFA.
- **Question to ponder:** Can you find a family of languages that have NFAs of size  $n$ , but no DFAs of size less than  $2^n$ ?

# Why This Matters

- We now have two perspectives on regular languages:
  - Regular languages are languages accepted by DFAs.
  - Regular languages are languages accepted by NFAs.
- We can now reason about the regular languages in two different ways.

**Time-Out for Announcements!**

# Problem Set Six

- Problem Set Five was due at 4:00PM today.
  - You can use a late day to extend the deadline to 4:00PM Saturday.
- Problem Set Six goes out today. It's due next Friday at 4:00PM.
  - Design DFAs and NFAs for a range of problems!
  - Explore formal language theory!
  - See some clever applications!

Back to CS103!

# The Regular Languages

# Regular Languages

- Let  $L \subseteq \Sigma^*$  be a language.
- We say that  $L$  is a **regular language** if there is a DFA  $D$  where  $\mathcal{L}(D) = L$ .
- Equivalently,  $L$  is a regular language if there is an NFA  $N$  where  $\mathcal{L}(N) = L$ .
- Key questions:
  - What do the regular languages “feel” like?
  - What properties do they have?
  - What languages *aren't* regular?

# Closure Under Union

- If  $L_1$  and  $L_2$  are languages over the alphabet  $\Sigma$ , the language  $L_1 \cup L_2$  is the language of all strings in at least one of the two languages.
- If  $L_1$  and  $L_2$  are regular languages, is  $L_1 \cup L_2$ ?

---

$L_1 = \{ w \in \{\mathbf{a}, \mathbf{b}\}^* \mid w \text{ has even length} \}$   
 $L_2 = \{ w \in \{\mathbf{a}, \mathbf{b}\}^* \mid w \text{ has length exactly three} \}$

Construct an NFA for  $L_1 \cup L_2$ .

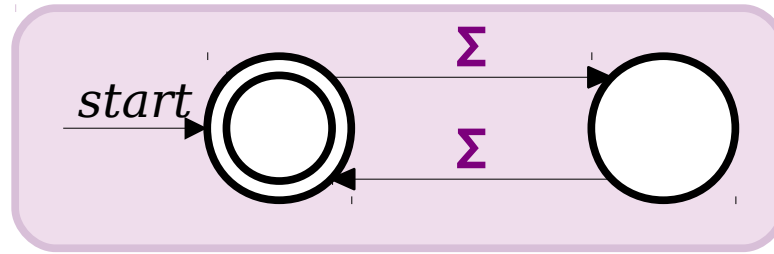

DFA for  $L_1$

---

$L_1 = \{ w \in \{a, b\}^* \mid w \text{ has even length} \}$   
 $L_2 = \{ w \in \{a, b\}^* \mid w \text{ has length exactly three} \}$   
Construct an NFA for  $L_1 \cup L_2$ .

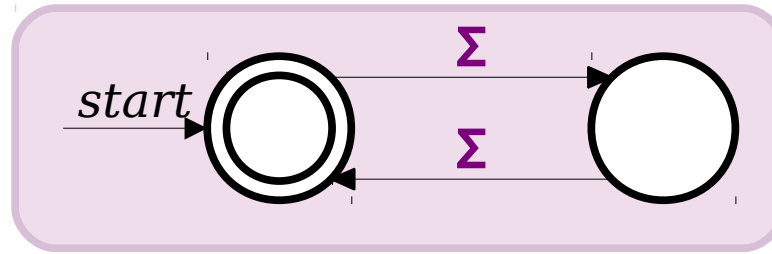

DFA for  $L_1$

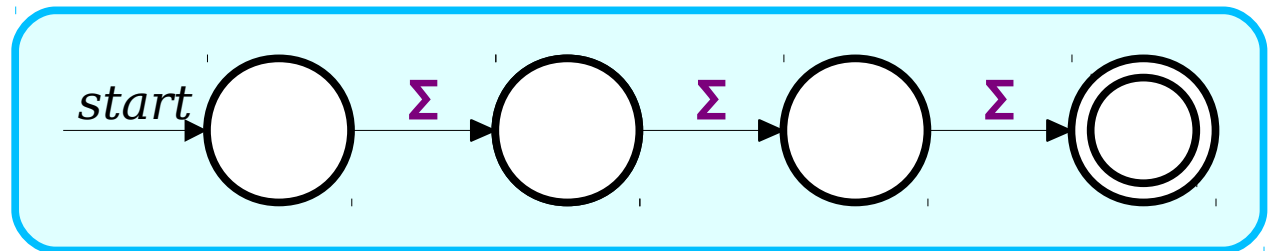

NFA for  $L_2$

$$L_1 = \{ w \in \{a, b\}^* \mid w \text{ has even length} \}$$

$$L_2 = \{ w \in \{a, b\}^* \mid w \text{ has length exactly three} \}$$

Construct an NFA for  $L_1 \cup L_2$ .

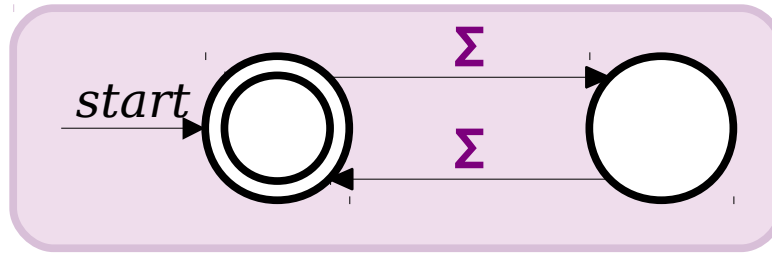

DFA for  $L_1$

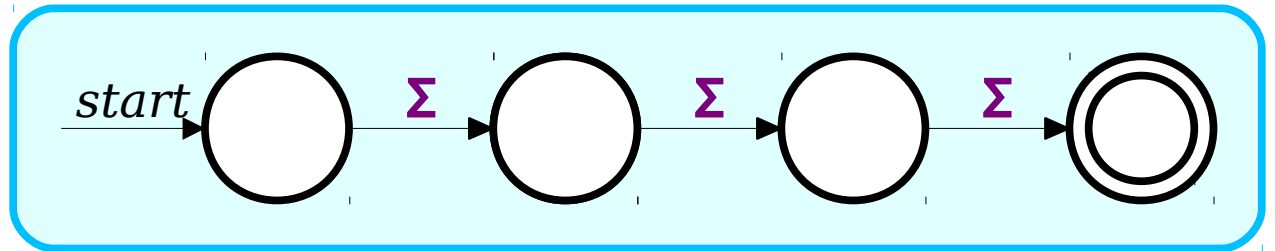
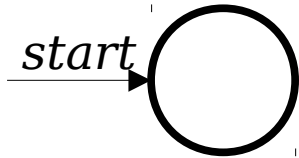

NFA for  $L_2$

$$L_1 = \{ w \in \{a, b\}^* \mid w \text{ has even length} \}$$

$$L_2 = \{ w \in \{a, b\}^* \mid w \text{ has length exactly three} \}$$

Construct an NFA for  $L_1 \cup L_2$ .

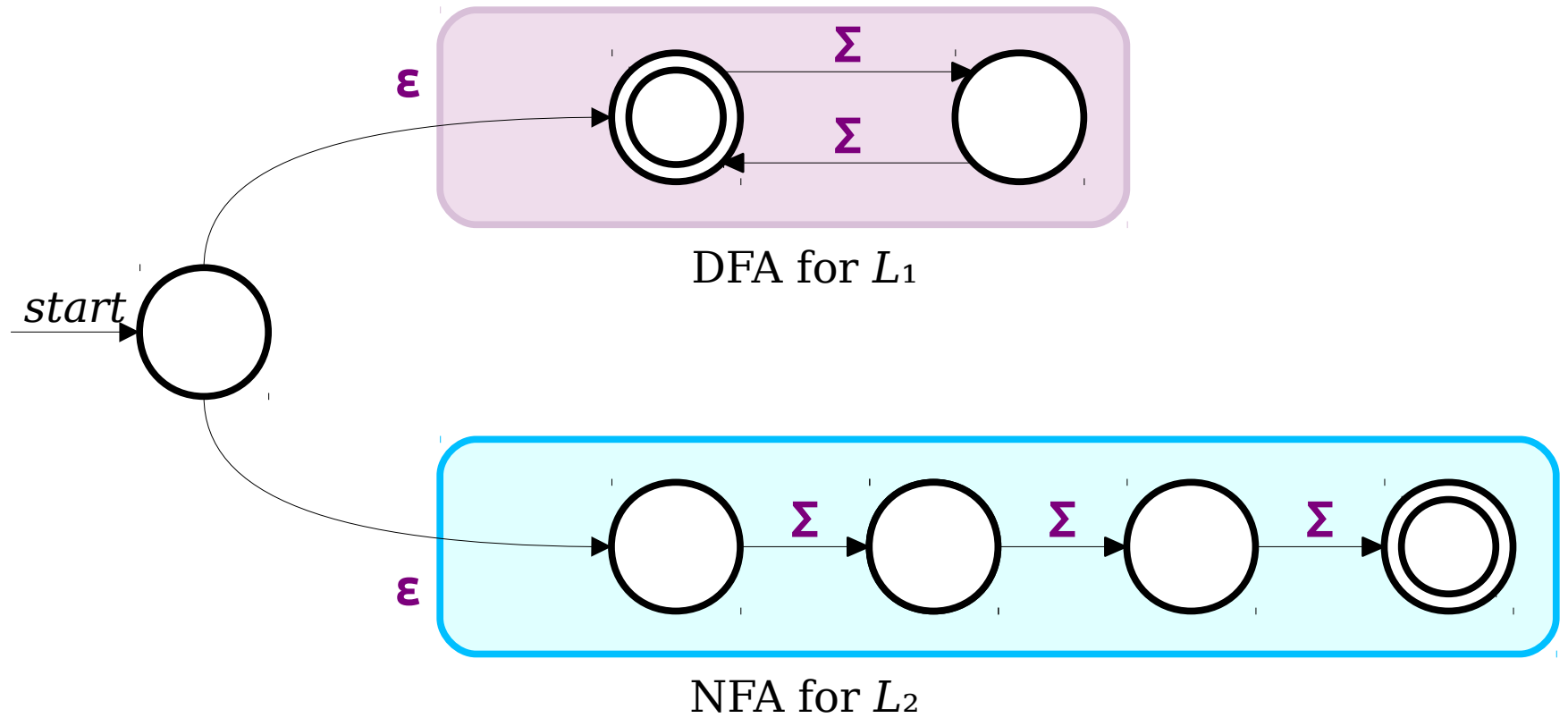

$$L_1 = \{ w \in \{a, b\}^* \mid w \text{ has even length} \}$$

$$L_2 = \{ w \in \{a, b\}^* \mid w \text{ has length exactly three} \}$$

Construct an NFA for  $L_1 \cup L_2$ .

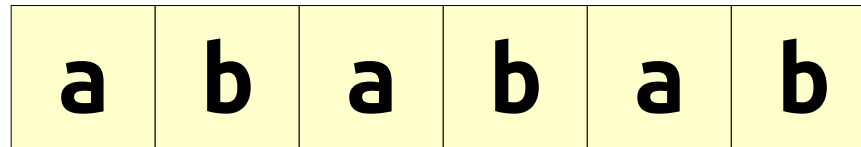
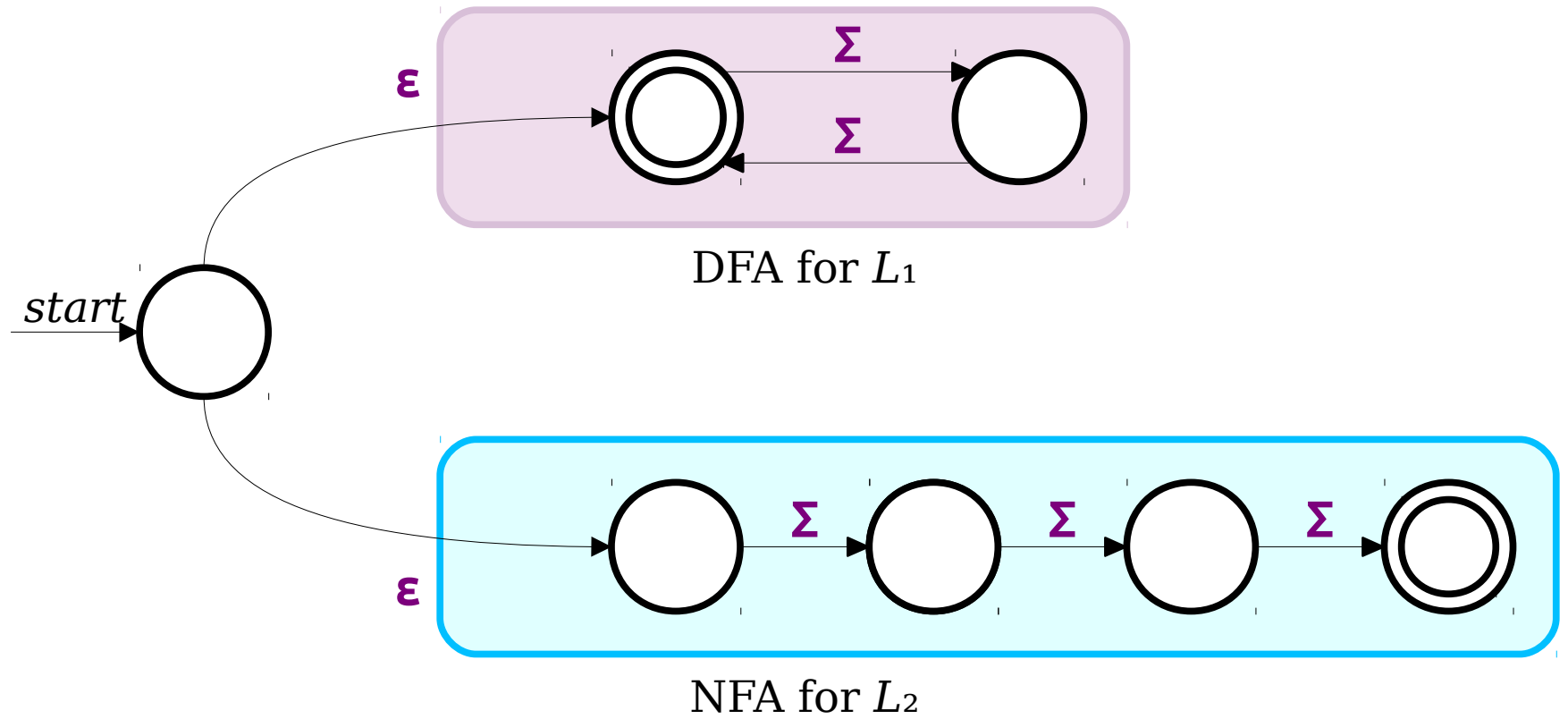

$L_1 = \{ w \in \{a, b\}^* \mid w \text{ has even length} \}$   
 $L_2 = \{ w \in \{a, b\}^* \mid w \text{ has length exactly three} \}$

Construct an NFA for  $L_1 \cup L_2$ .

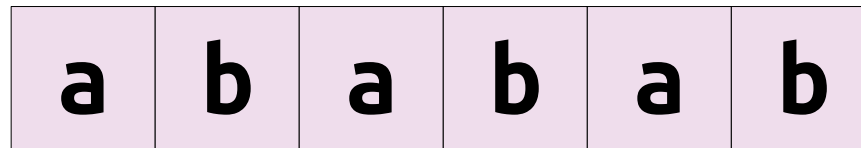
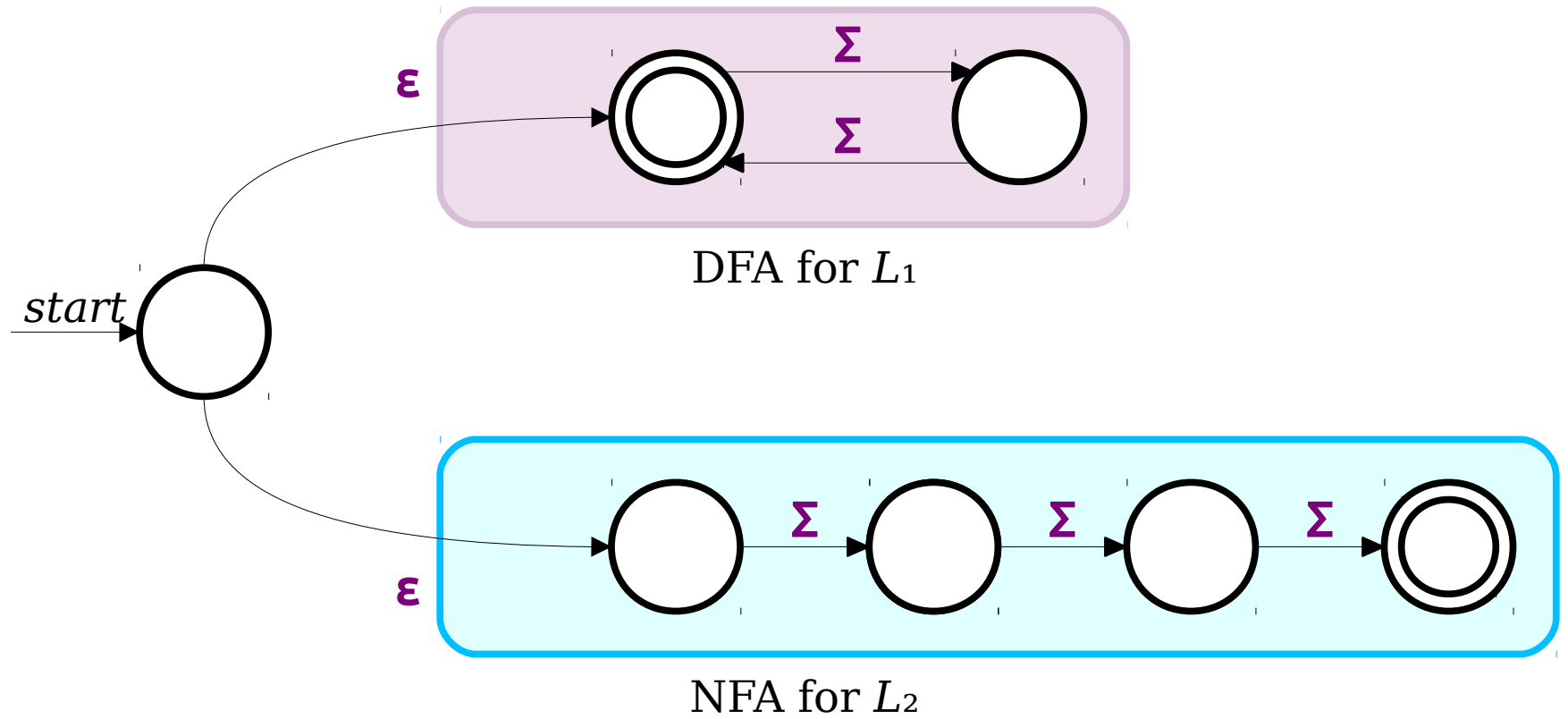

$L_1 = \{ w \in \{a, b\}^* \mid w \text{ has even length} \}$   
 $L_2 = \{ w \in \{a, b\}^* \mid w \text{ has length exactly three} \}$

Construct an NFA for  $L_1 \cup L_2$ .

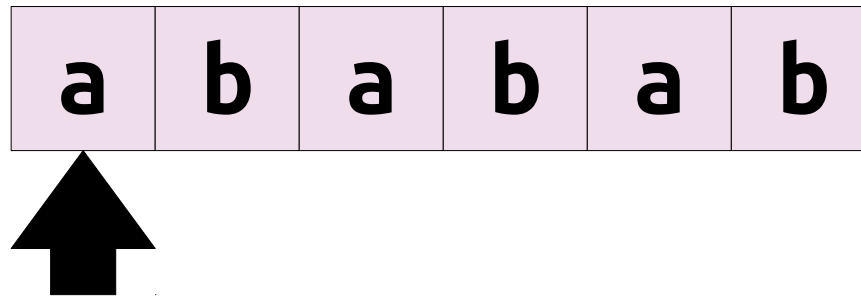
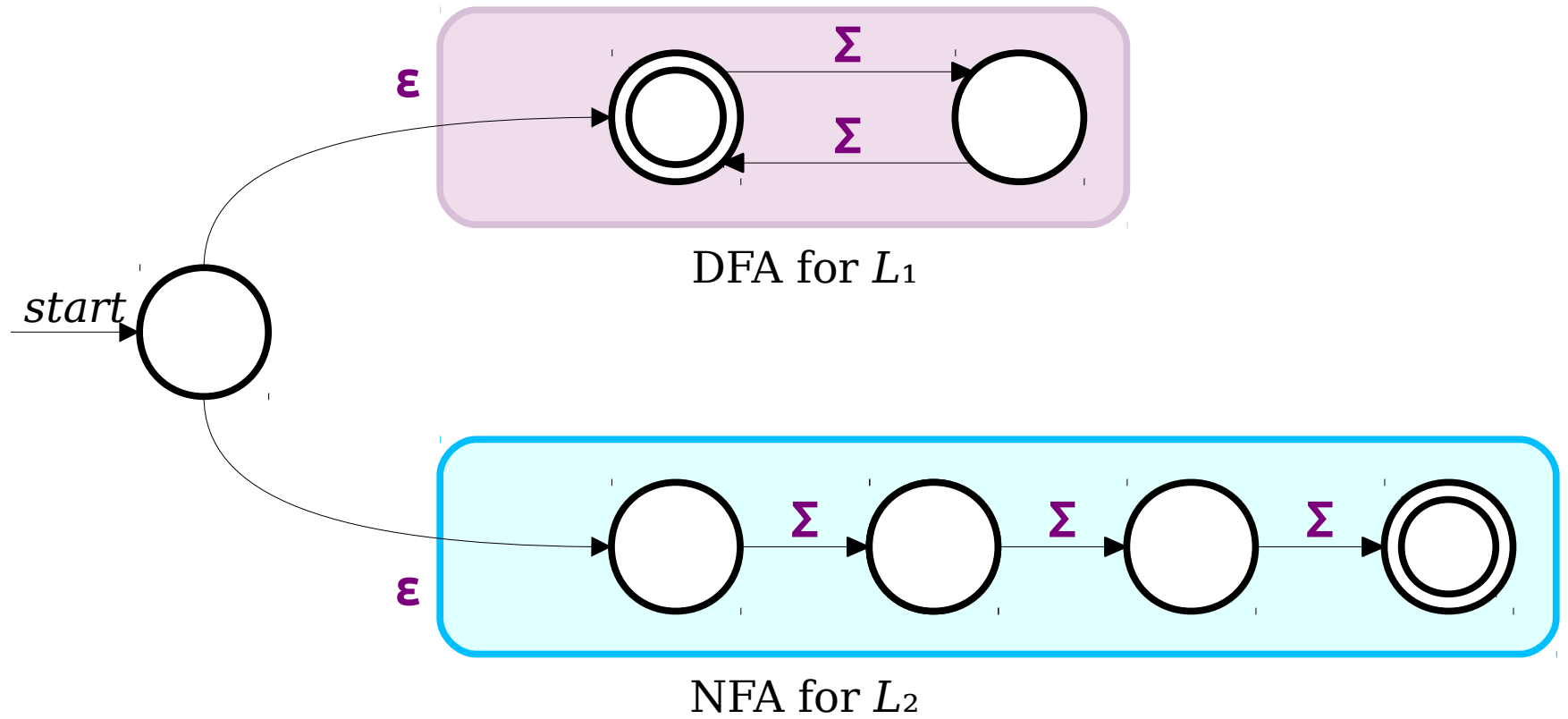

$L_1 = \{ w \in \{a, b\}^* \mid w \text{ has even length} \}$   
 $L_2 = \{ w \in \{a, b\}^* \mid w \text{ has length exactly three} \}$   
 Construct an NFA for  $L_1 \cup L_2$ .

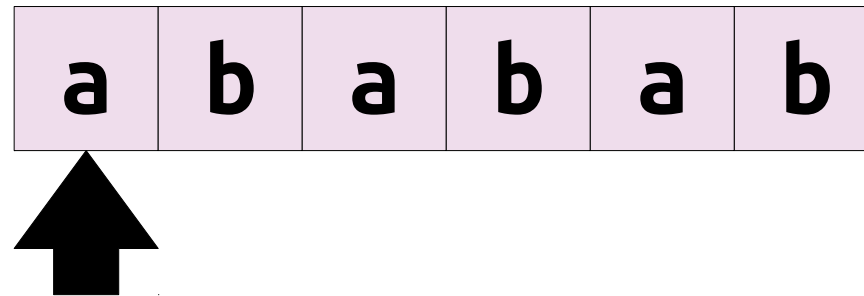
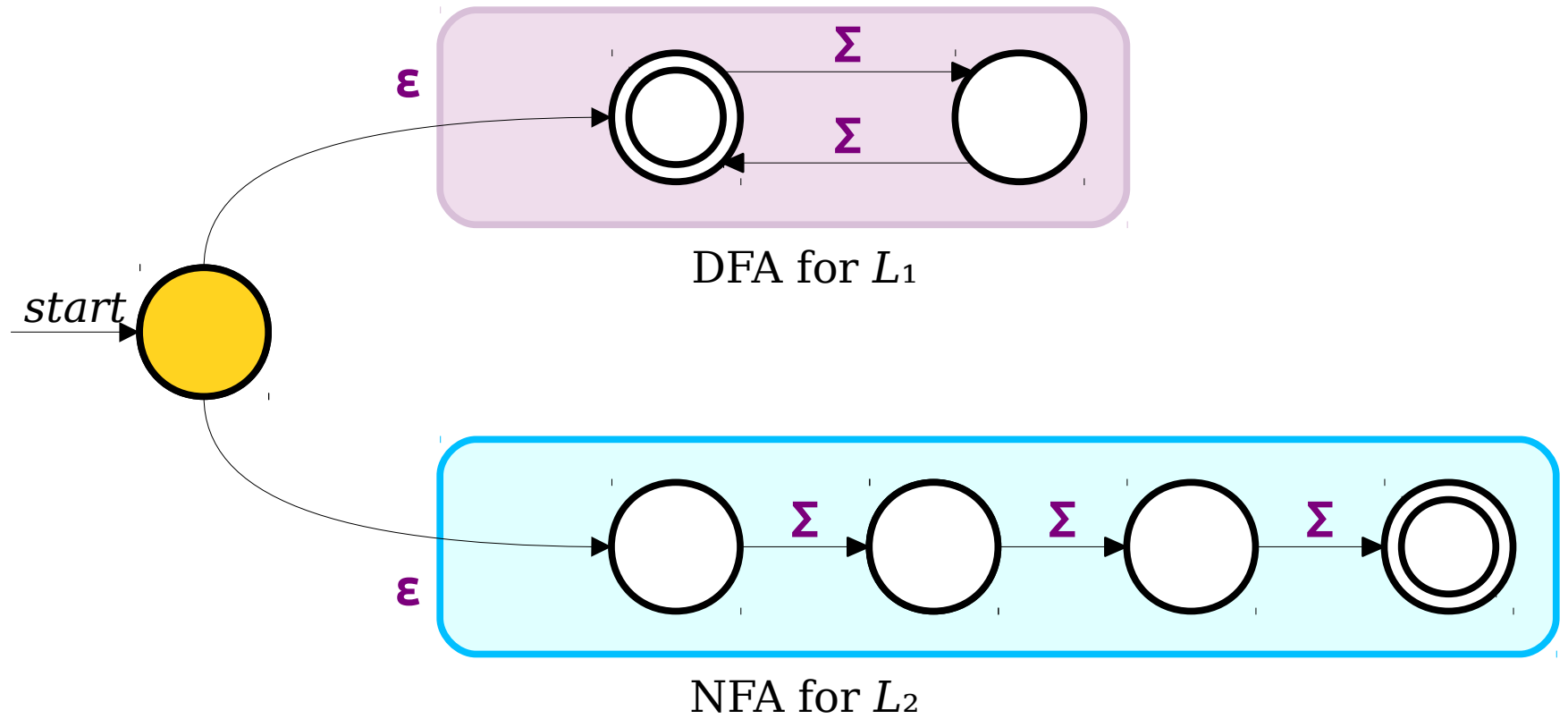

$$L_1 = \{ w \in \{a, b\}^* \mid w \text{ has even length} \}$$

$$L_2 = \{ w \in \{a, b\}^* \mid w \text{ has length exactly three} \}$$

Construct an NFA for  $L_1 \cup L_2$ .

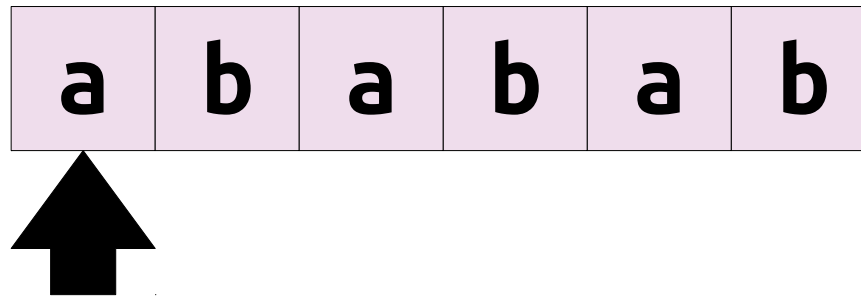
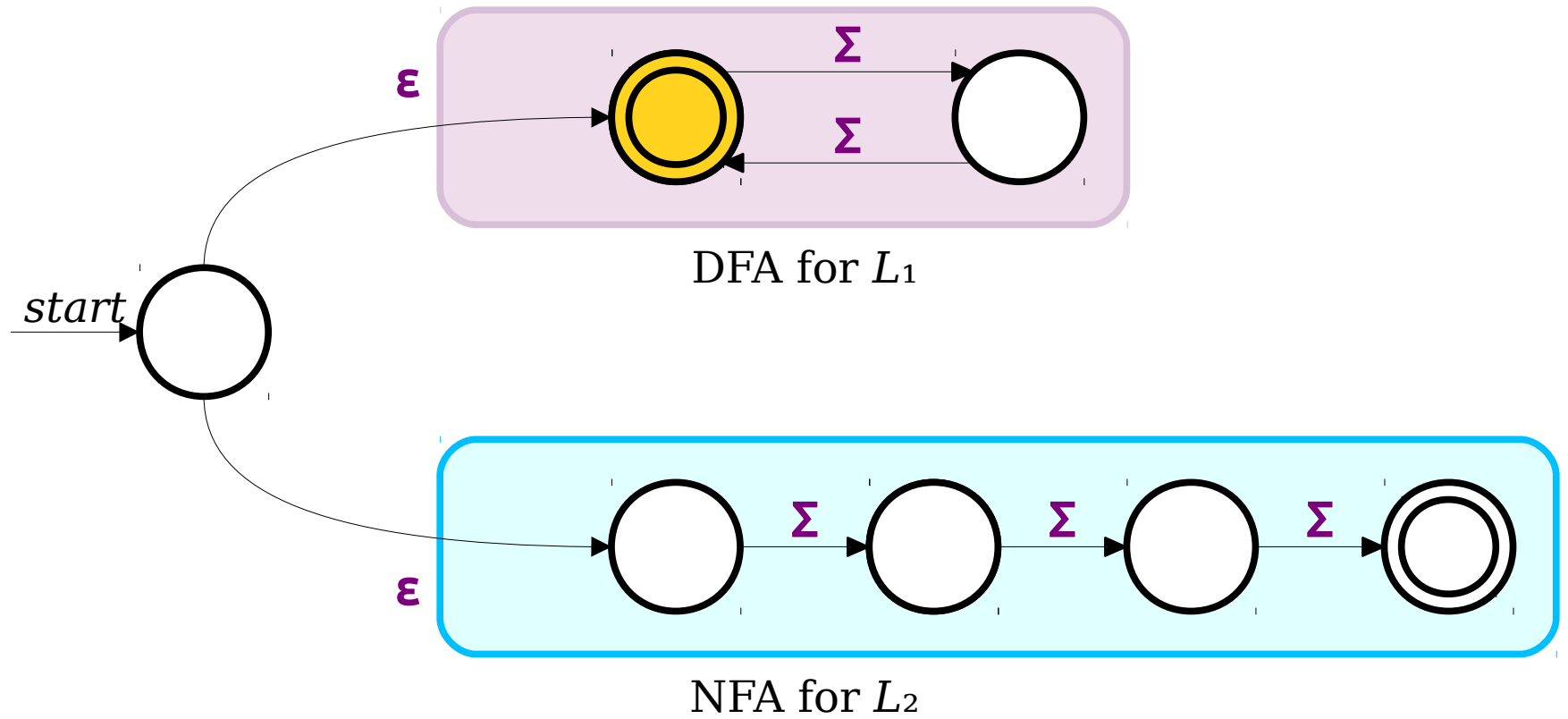

$L_1 = \{ w \in \{a, b\}^* \mid w \text{ has even length} \}$   
 $L_2 = \{ w \in \{a, b\}^* \mid w \text{ has length exactly three} \}$   
 Construct an NFA for  $L_1 \cup L_2$ .

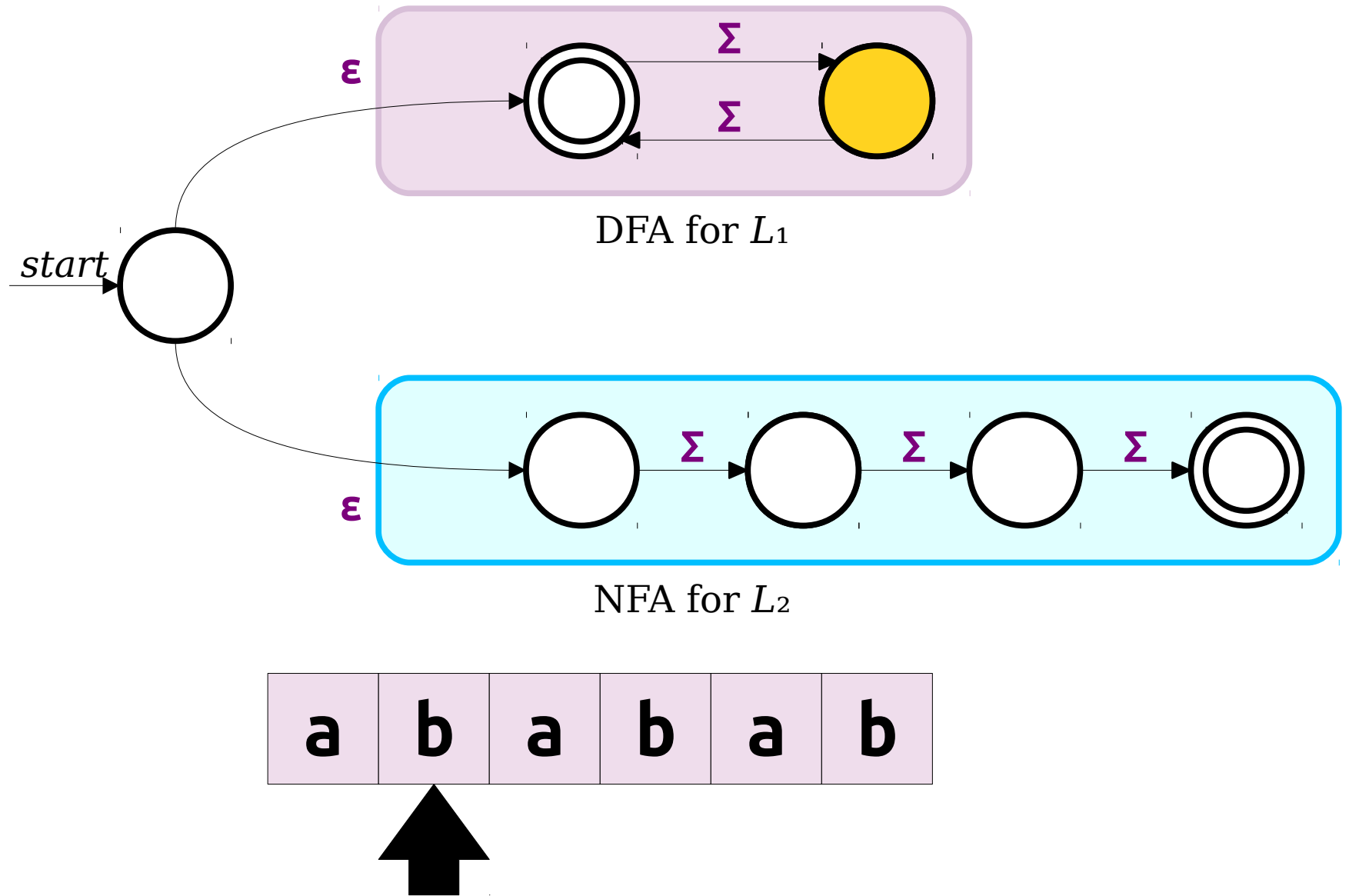

$$L_1 = \{ w \in \{a, b\}^* \mid w \text{ has even length} \}$$

$$L_2 = \{ w \in \{a, b\}^* \mid w \text{ has length exactly three} \}$$

Construct an NFA for  $L_1 \cup L_2$ .

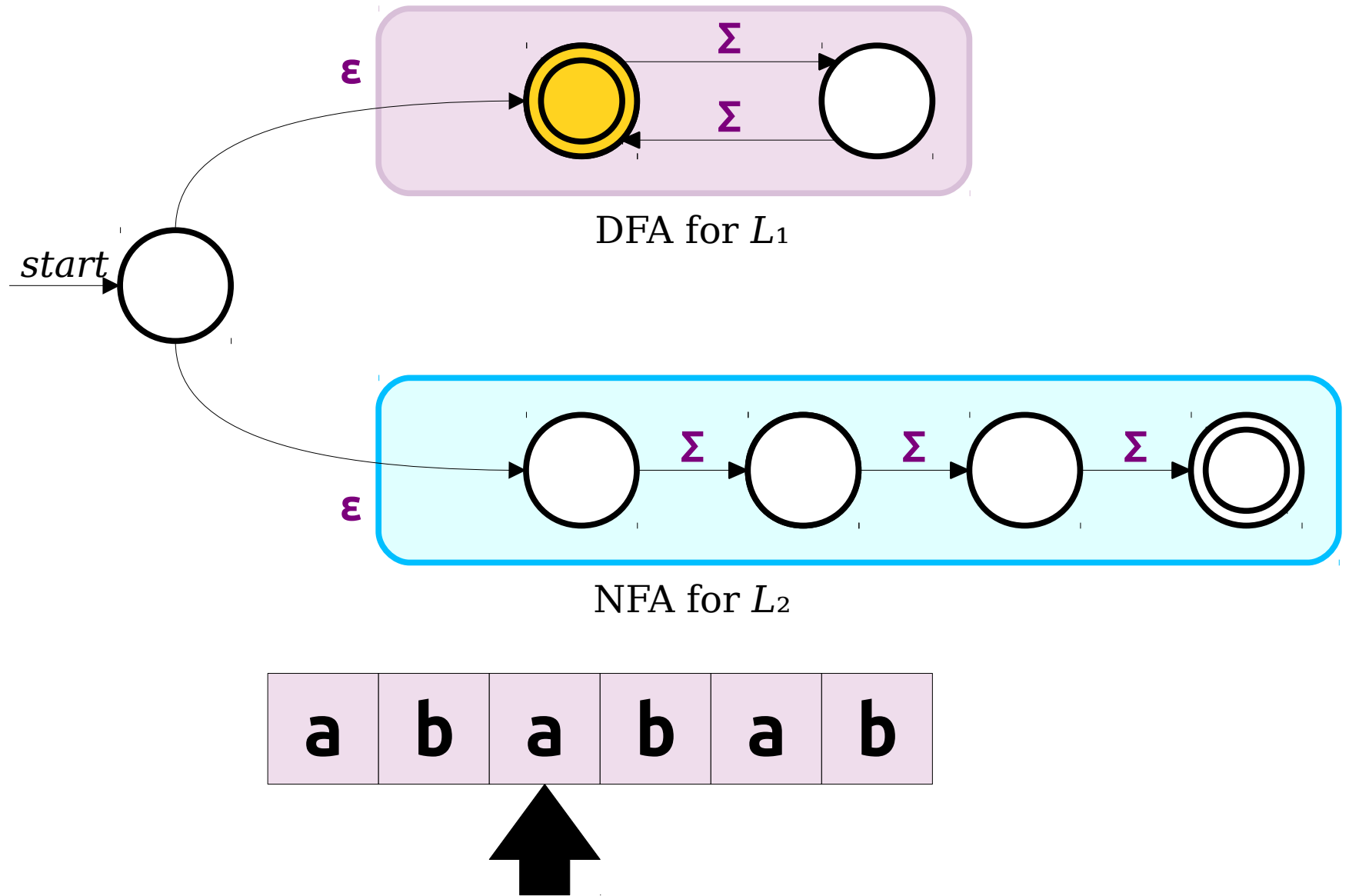

$$L_1 = \{ w \in \{a, b\}^* \mid w \text{ has even length} \}$$

$$L_2 = \{ w \in \{a, b\}^* \mid w \text{ has length exactly three} \}$$

Construct an NFA for  $L_1 \cup L_2$ .

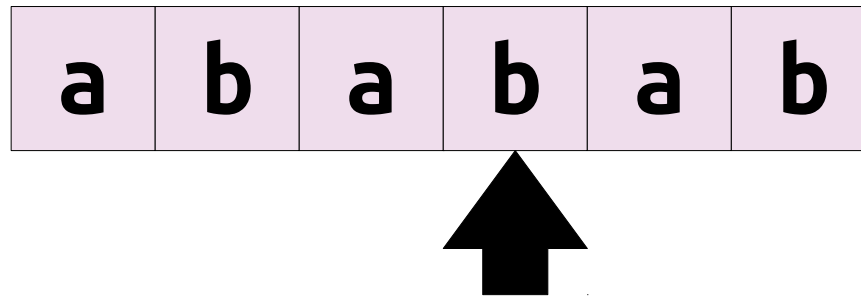
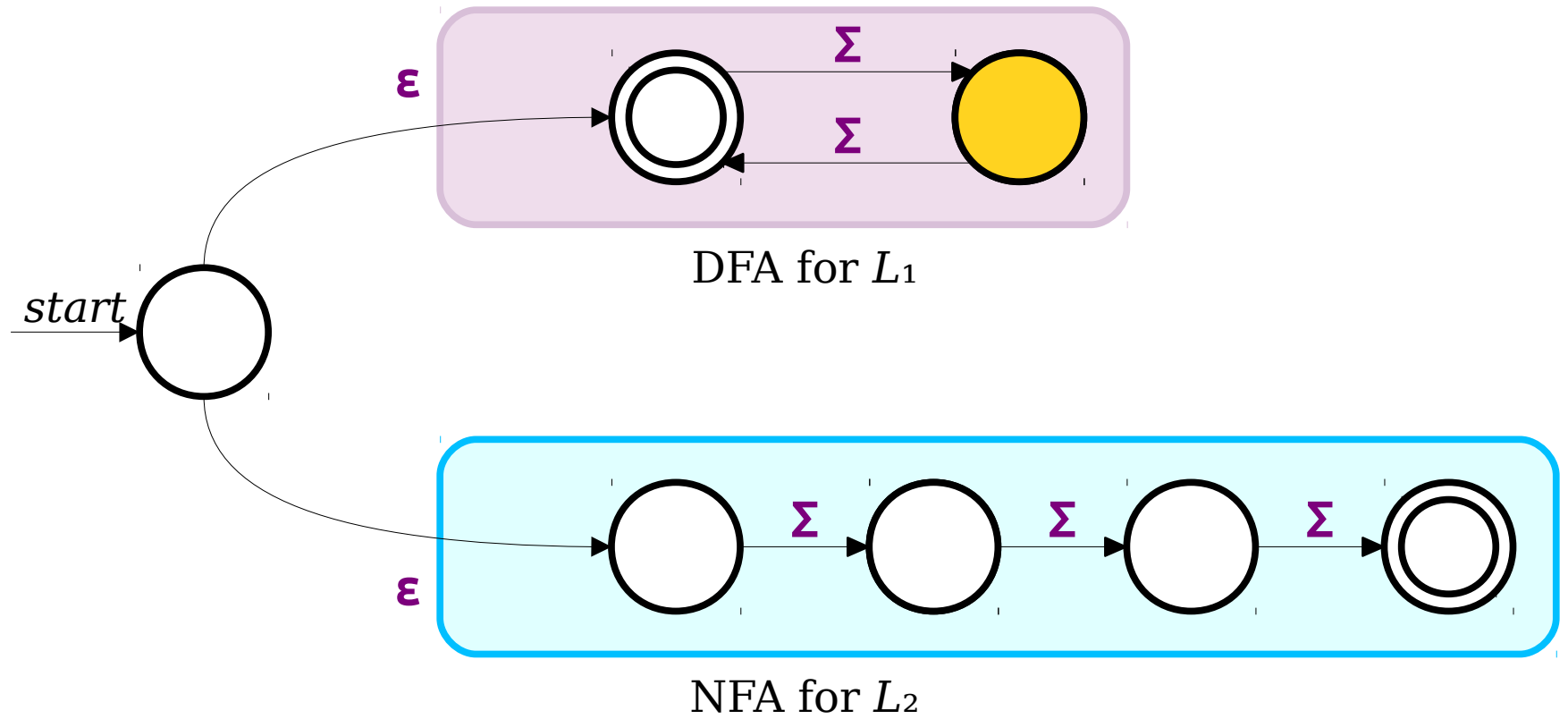

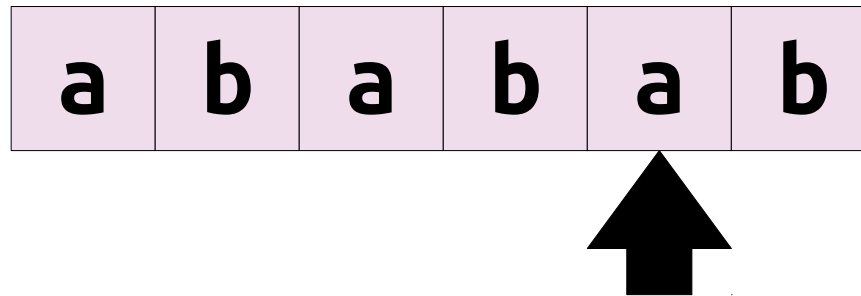
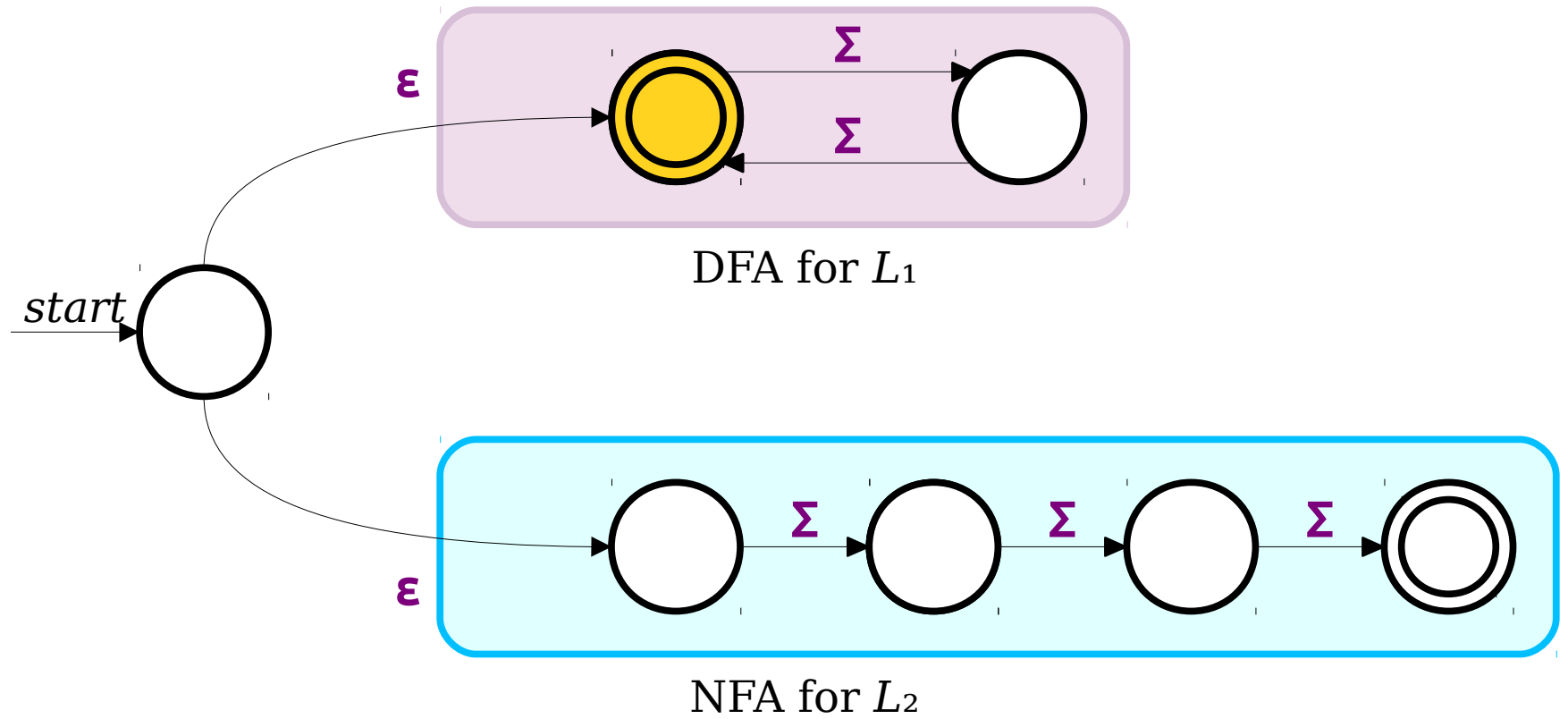

---

$L_1 = \{ w \in \{a, b\}^* \mid w \text{ has even length} \}$   
 $L_2 = \{ w \in \{a, b\}^* \mid w \text{ has length exactly three} \}$   
 Construct an NFA for  $L_1 \cup L_2$ .

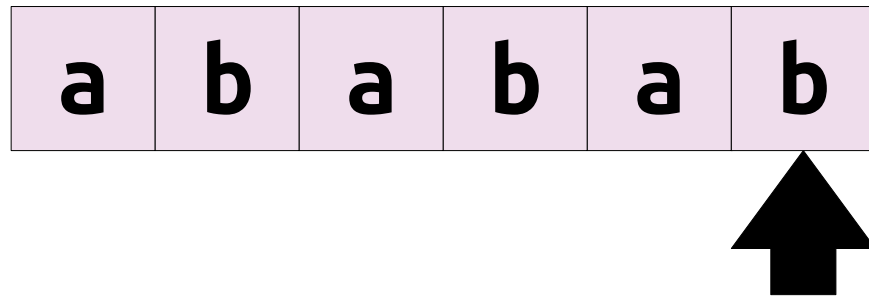
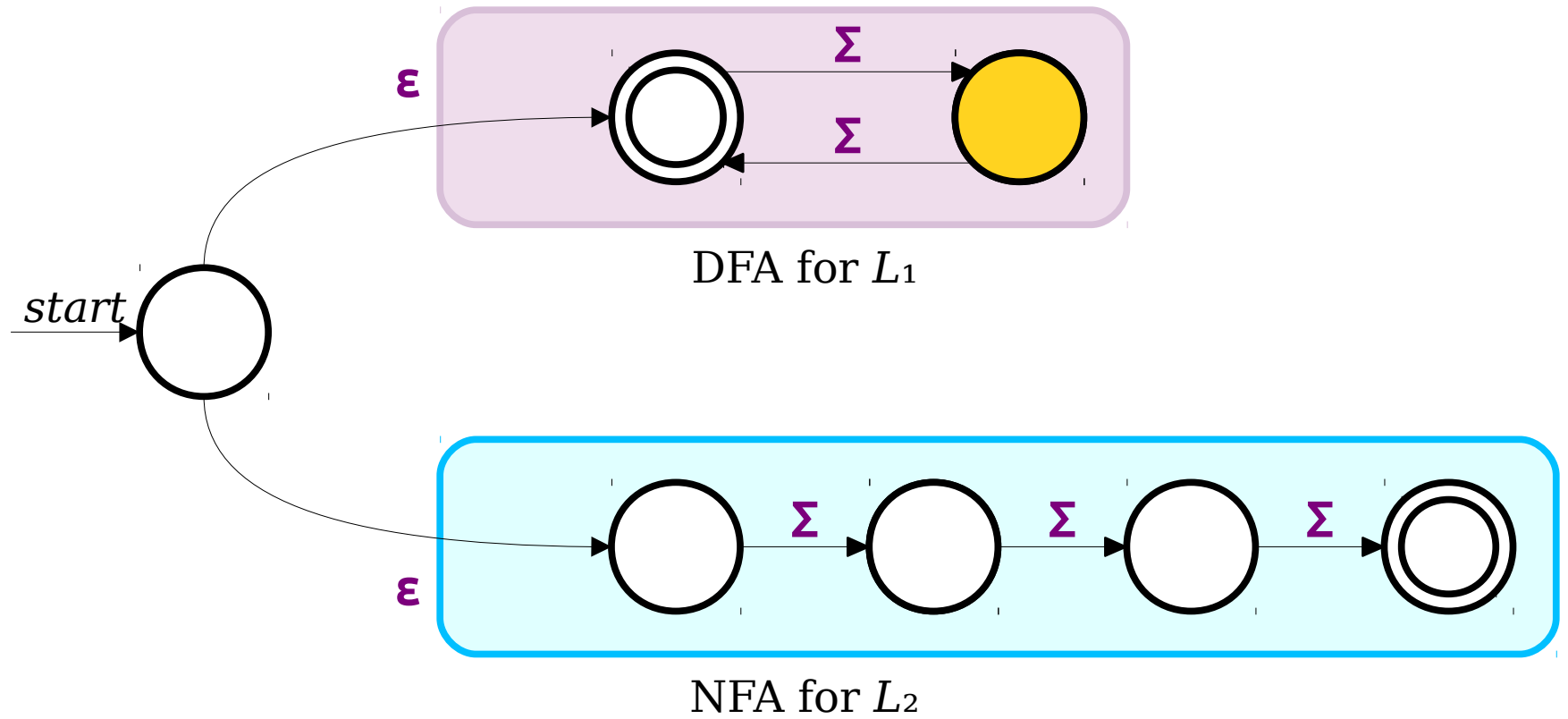

$L_1 = \{ w \in \{a, b\}^* \mid w \text{ has even length} \}$   
 $L_2 = \{ w \in \{a, b\}^* \mid w \text{ has length exactly three} \}$

Construct an NFA for  $L_1 \cup L_2$ .



$L_1 = \{ w \in \{a, b\}^* \mid w \text{ has even length} \}$   
 $L_2 = \{ w \in \{a, b\}^* \mid w \text{ has length exactly three} \}$

Construct an NFA for  $L_1 \cup L_2$ .

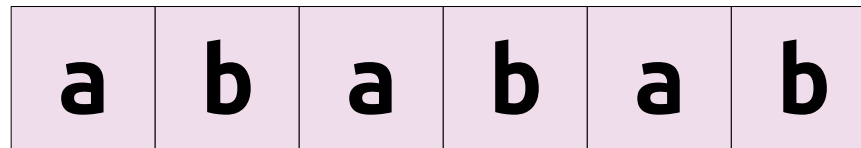
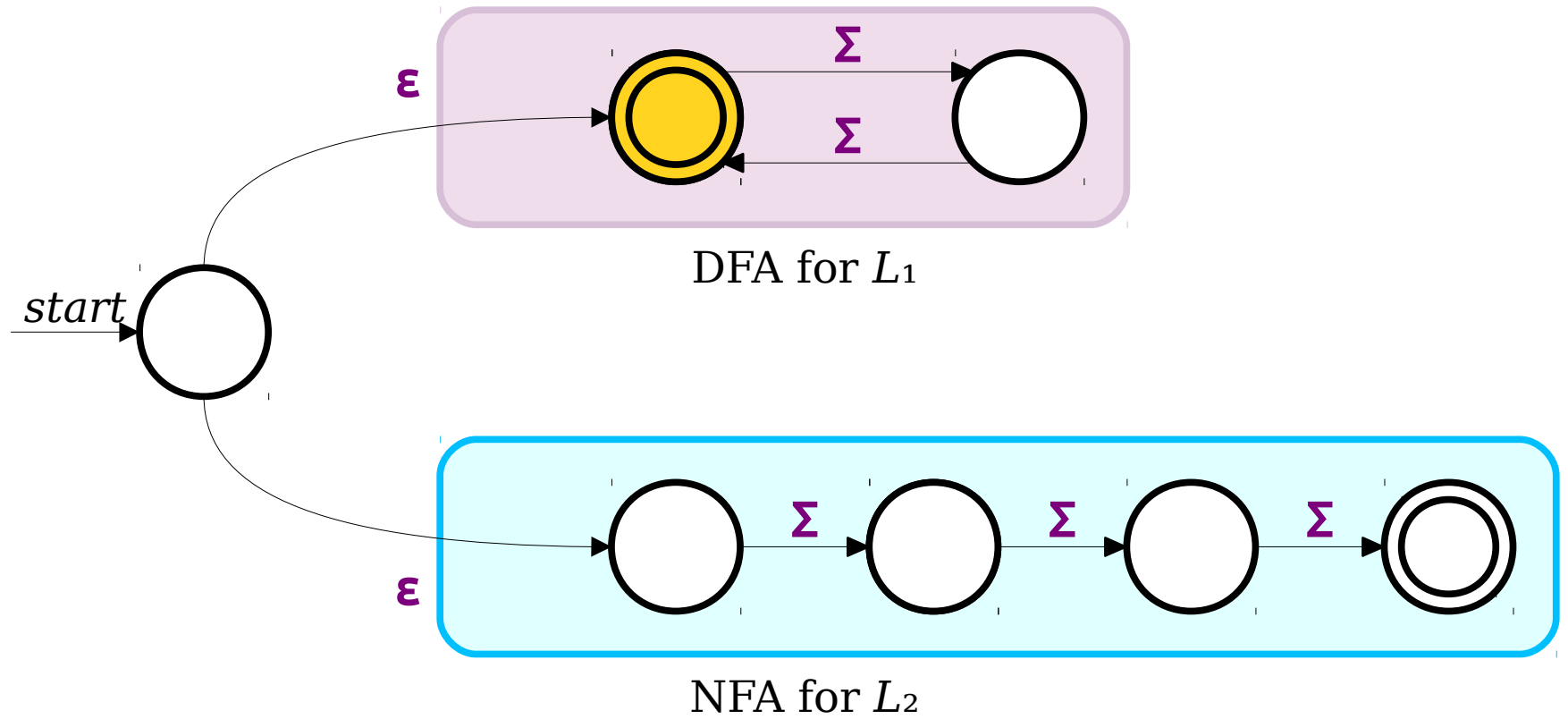

$$L_1 = \{ w \in \{a, b\}^* \mid w \text{ has even length} \}$$

$$L_2 = \{ w \in \{a, b\}^* \mid w \text{ has length exactly three} \}$$

Construct an NFA for  $L_1 \cup L_2$ .

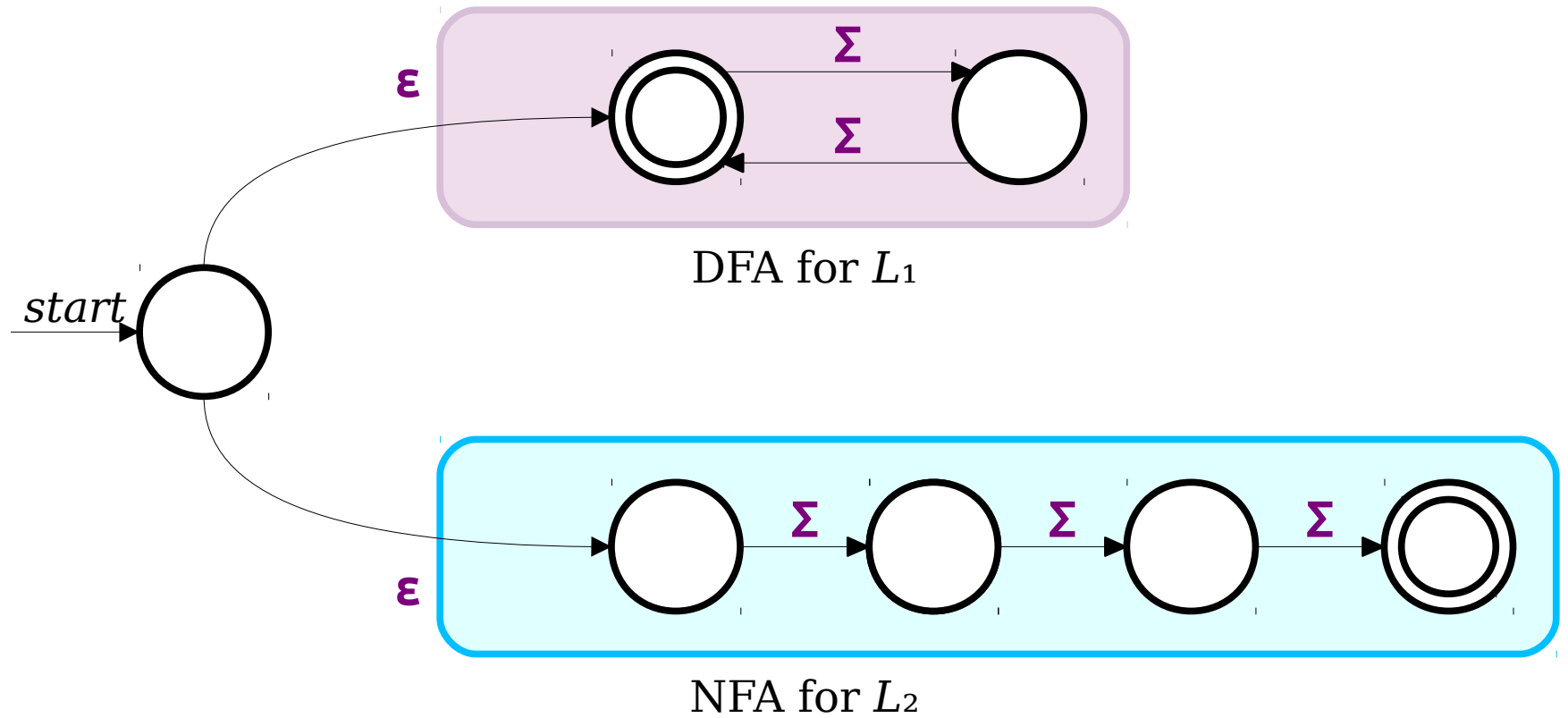

$$L_1 = \{ w \in \{a, b\}^* \mid w \text{ has even length} \}$$

$$L_2 = \{ w \in \{a, b\}^* \mid w \text{ has length exactly three} \}$$

Construct an NFA for  $L_1 \cup L_2$ .

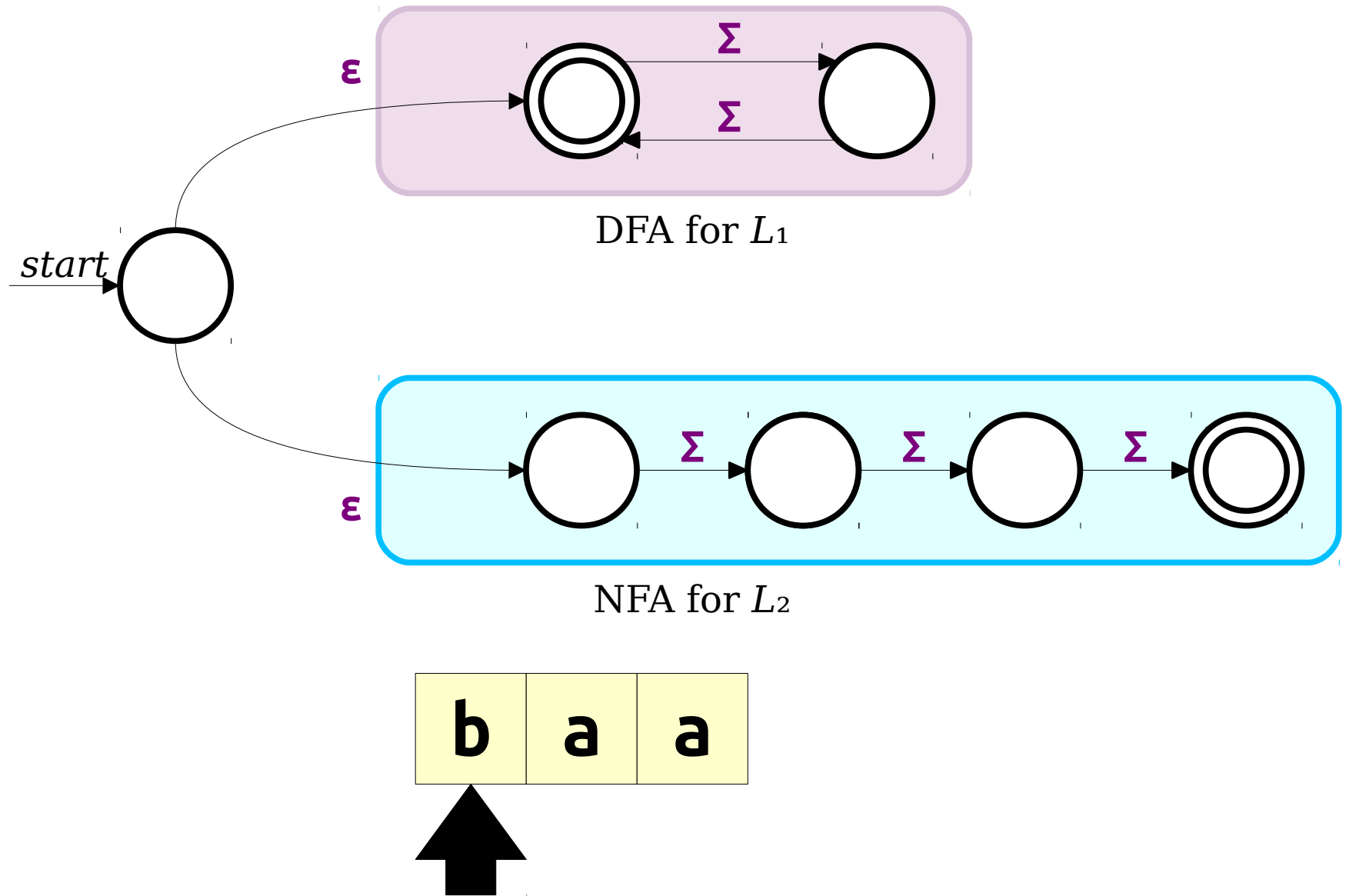

$$L_1 = \{ w \in \{a, b\}^* \mid w \text{ has even length} \}$$

$$L_2 = \{ w \in \{a, b\}^* \mid w \text{ has length exactly three} \}$$

Construct an NFA for  $L_1 \cup L_2$ .

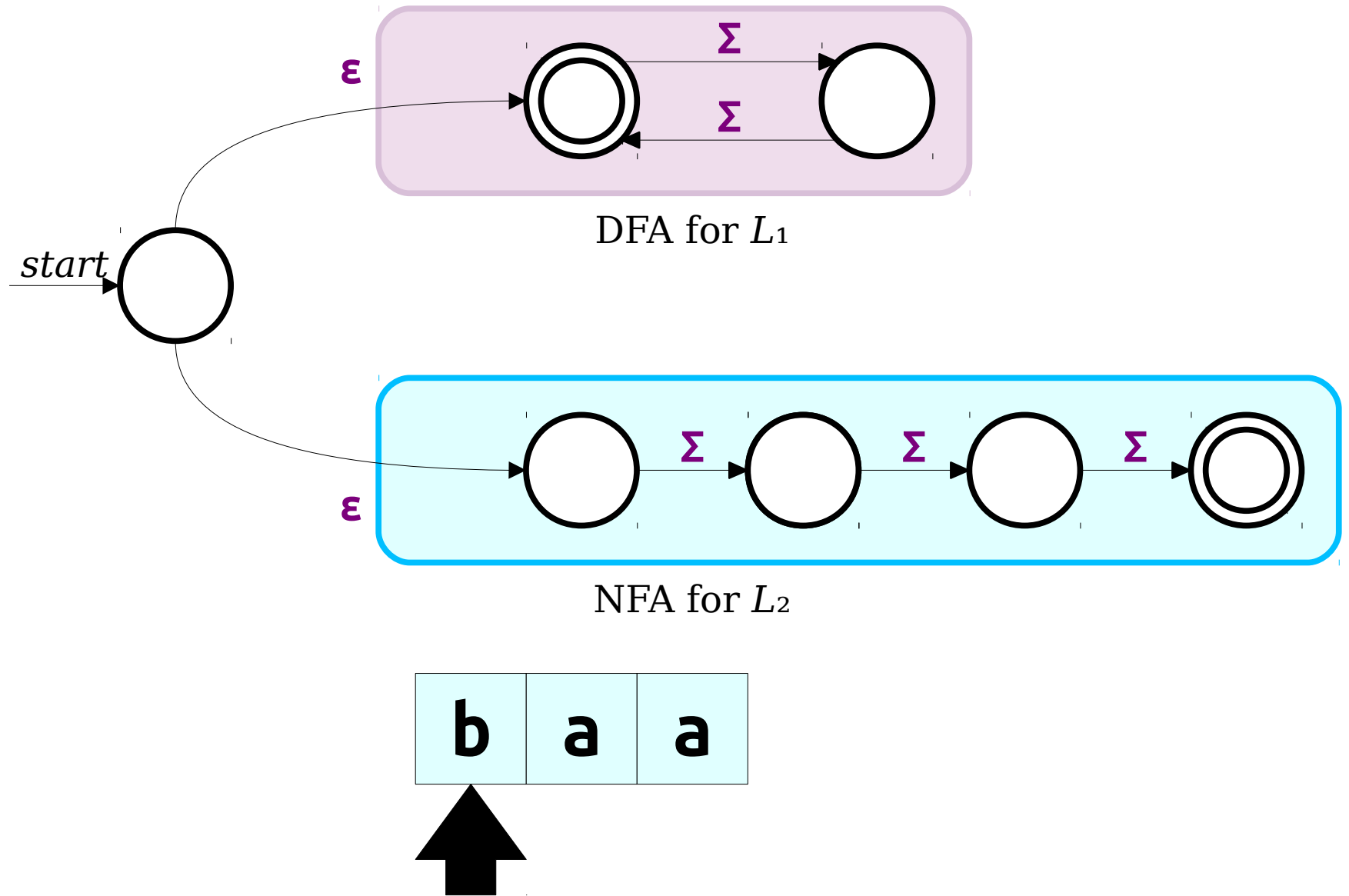

$$L_1 = \{ w \in \{a, b\}^* \mid w \text{ has even length} \}$$

$$L_2 = \{ w \in \{a, b\}^* \mid w \text{ has length exactly three} \}$$

Construct an NFA for  $L_1 \cup L_2$ .

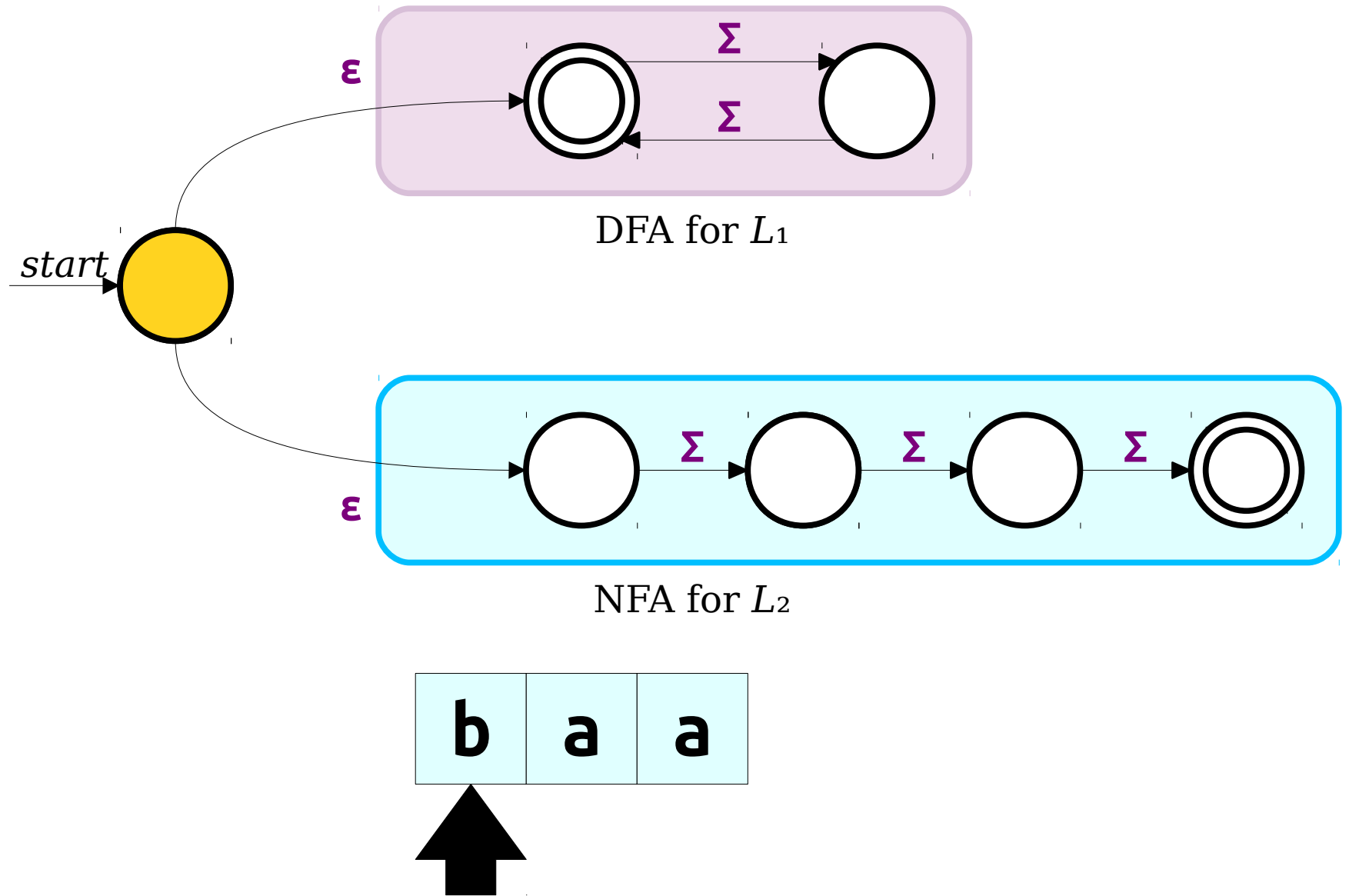

$L_1 = \{ w \in \{a, b\}^* \mid w \text{ has even length} \}$   
 $L_2 = \{ w \in \{a, b\}^* \mid w \text{ has length exactly three} \}$   
 Construct an NFA for  $L_1 \cup L_2$ .

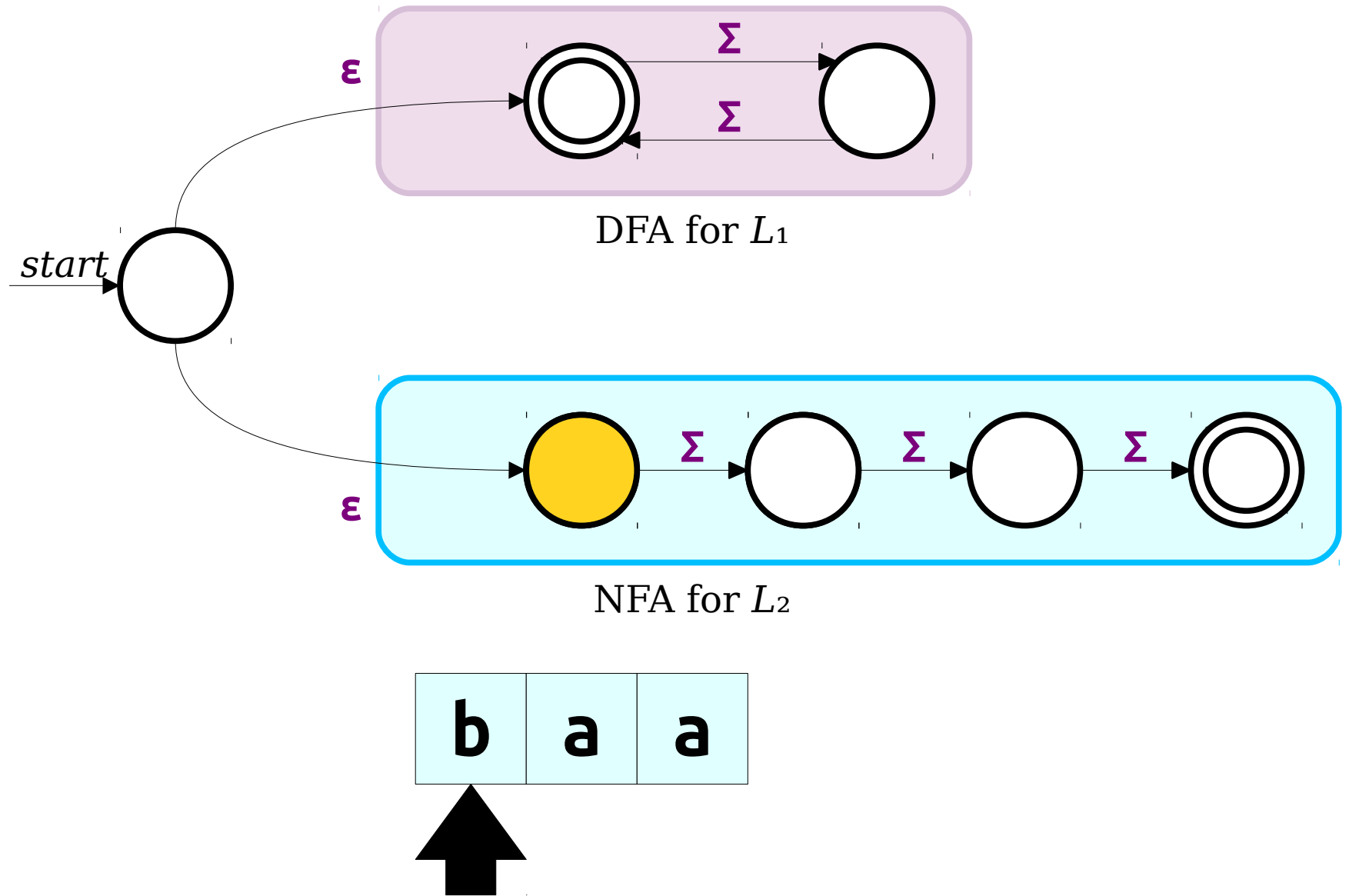

$$L_1 = \{ w \in \{a, b\}^* \mid w \text{ has even length} \}$$

$$L_2 = \{ w \in \{a, b\}^* \mid w \text{ has length exactly three} \}$$

Construct an NFA for  $L_1 \cup L_2$ .

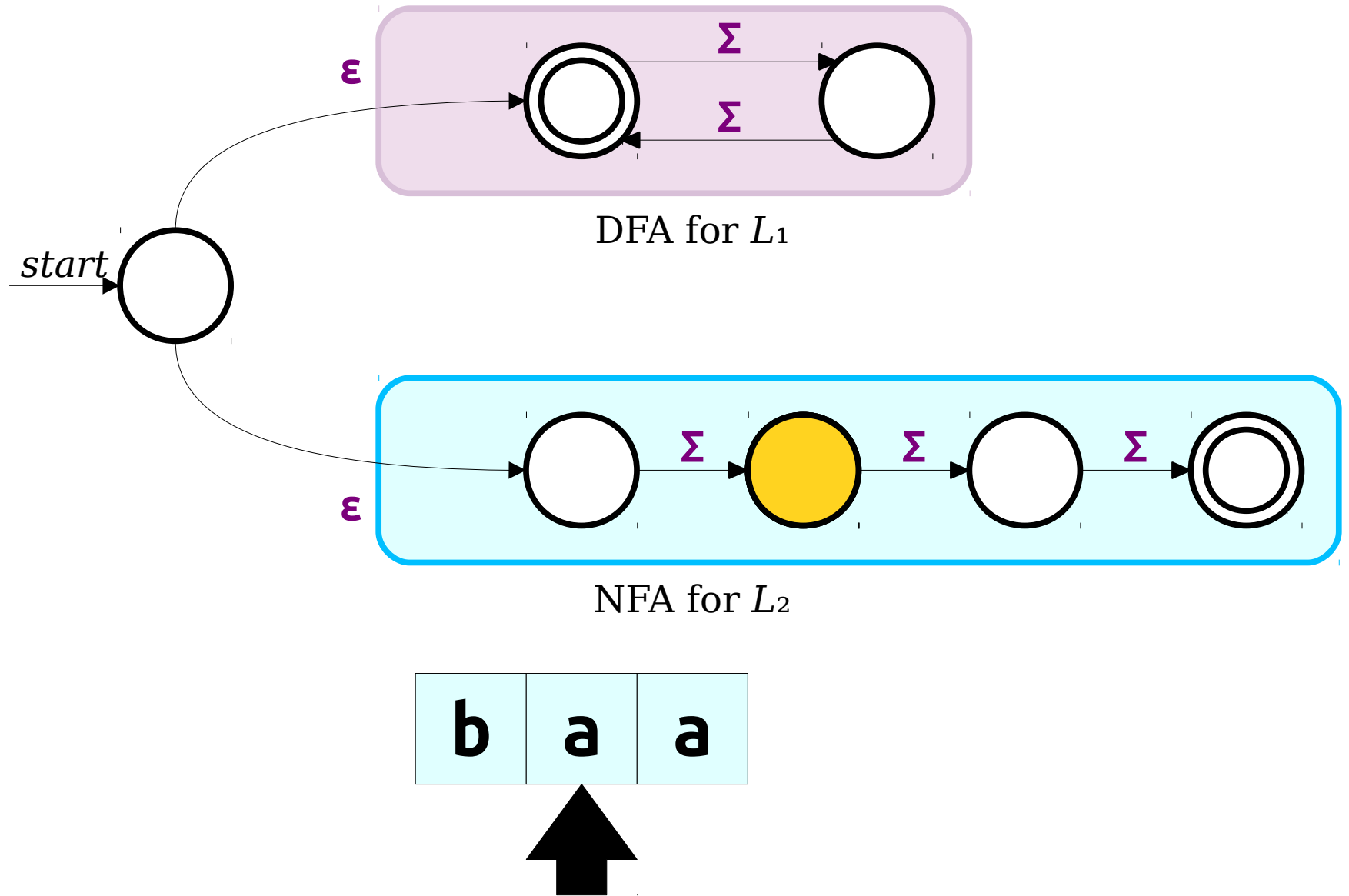

$$L_1 = \{ w \in \{a, b\}^* \mid w \text{ has even length} \}$$

$$L_2 = \{ w \in \{a, b\}^* \mid w \text{ has length exactly three} \}$$

Construct an NFA for  $L_1 \cup L_2$ .

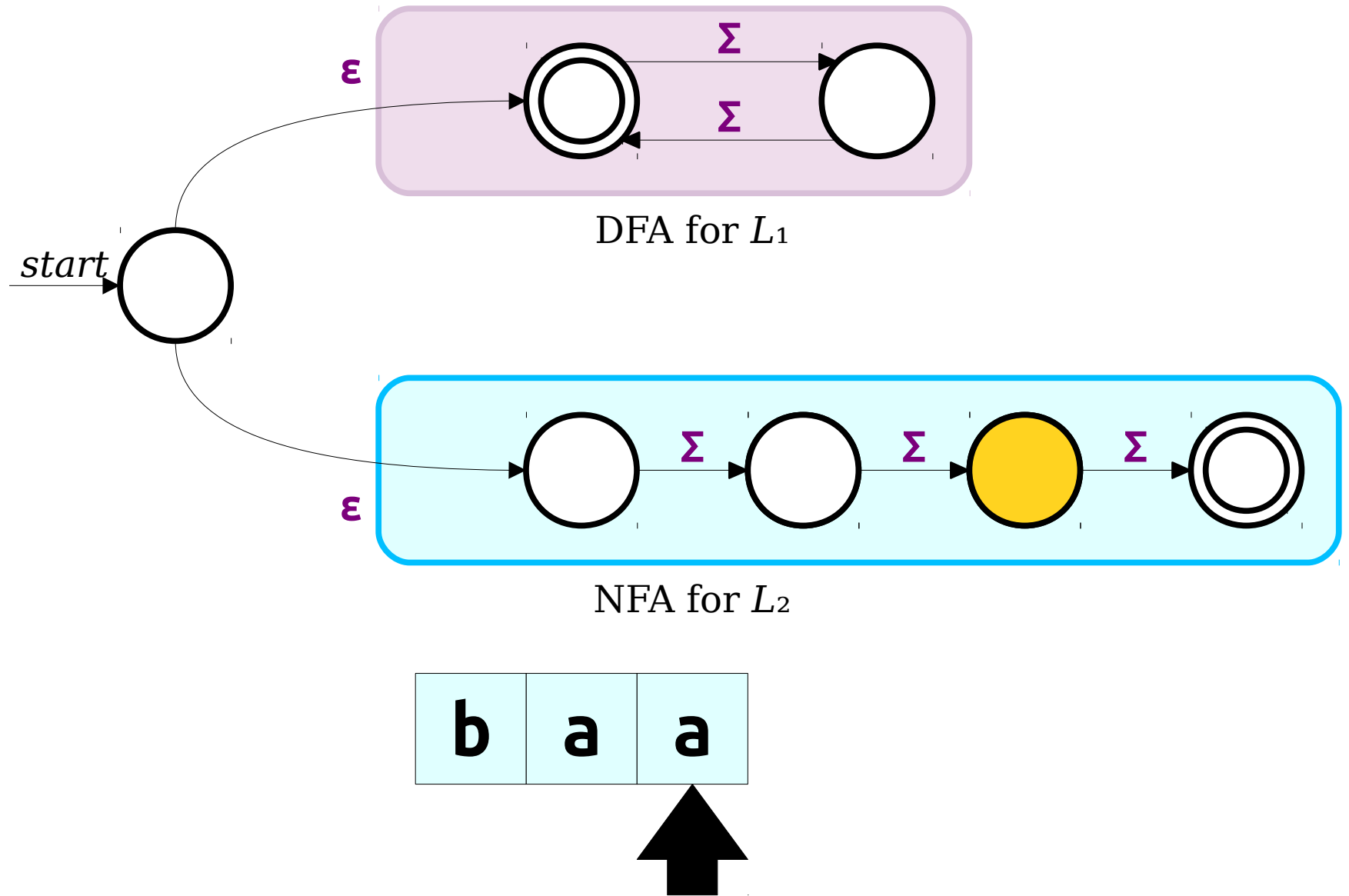

$$L_1 = \{ w \in \{a, b\}^* \mid w \text{ has even length} \}$$

$$L_2 = \{ w \in \{a, b\}^* \mid w \text{ has length exactly three} \}$$

Construct an NFA for  $L_1 \cup L_2$ .

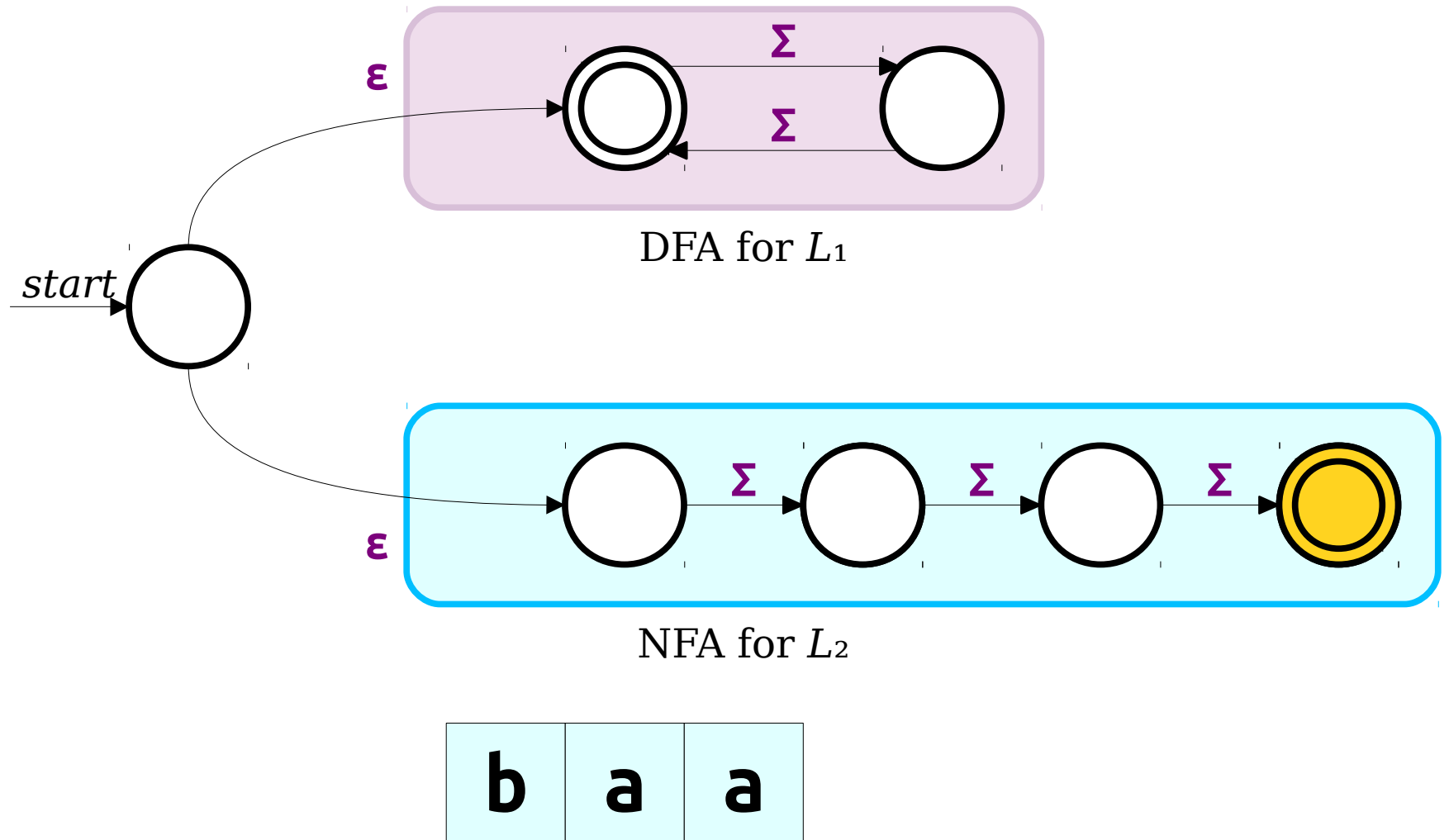

$L_1 = \{ w \in \{a, b\}^* \mid w \text{ has even length} \}$   
 $L_2 = \{ w \in \{a, b\}^* \mid w \text{ has length exactly three} \}$

Construct an NFA for  $L_1 \cup L_2$ .

# Closure Under Intersection

- If  $L_1$  and  $L_2$  are languages over  $\Sigma$ , then  $L_1 \cap L_2$  is the language of strings in both  $L_1$  and  $L_2$ .
- Question: If  $L_1$  and  $L_2$  are regular, is  $L_1 \cap L_2$  regular as well?

# Closure Under Intersection

- If  $L_1$  and  $L_2$  are languages over  $\Sigma$ , then  $L_1 \cap L_2$  is the language of strings in both  $L_1$  and  $L_2$ .
- Question: If  $L_1$  and  $L_2$  are regular, is  $L_1 \cap L_2$  regular as well?

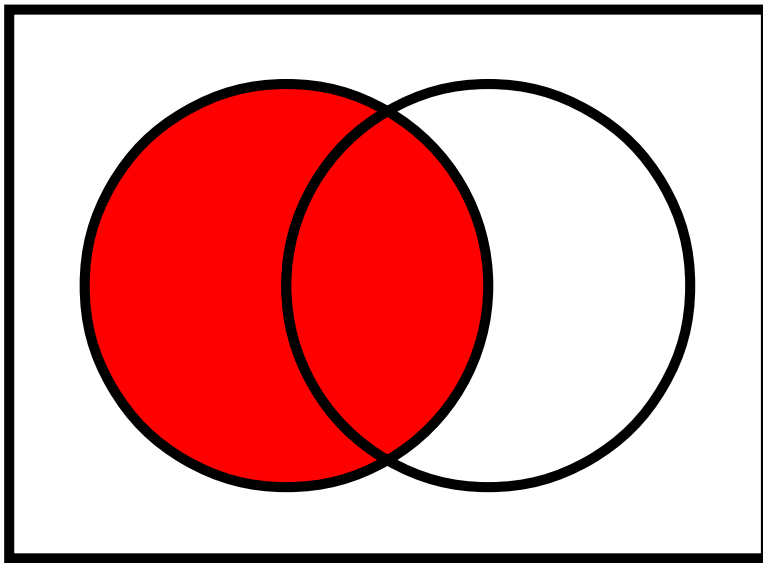

$L_1$

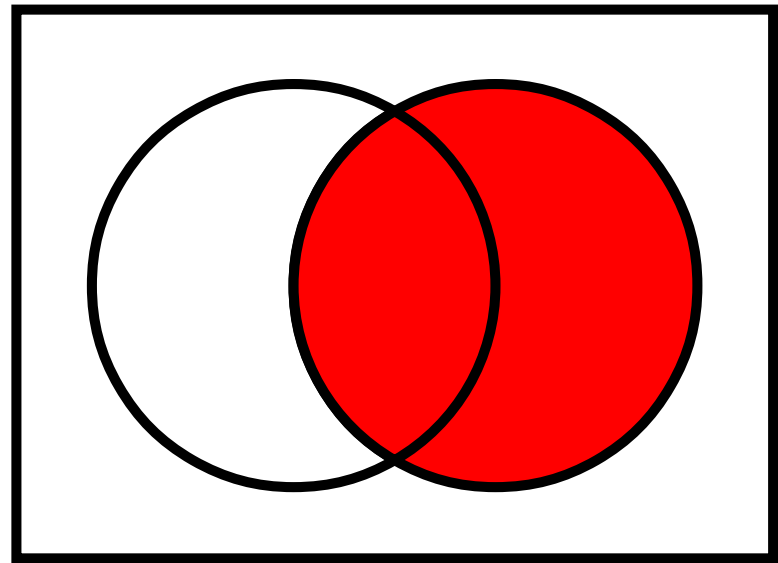

$L_2$

# Closure Under Intersection

- If  $L_1$  and  $L_2$  are languages over  $\Sigma$ , then  $L_1 \cap L_2$  is the language of strings in both  $L_1$  and  $L_2$ .
- Question: If  $L_1$  and  $L_2$  are regular, is  $L_1 \cap L_2$  regular as well?

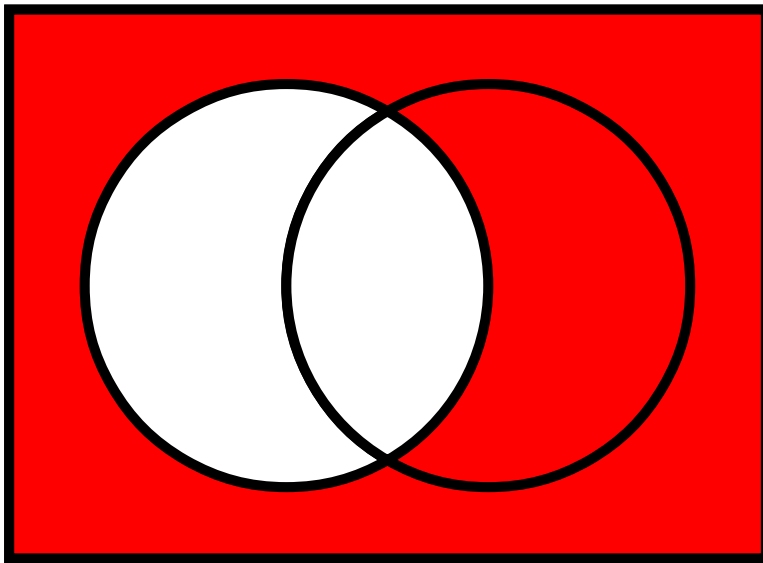

$\bar{L}_1$

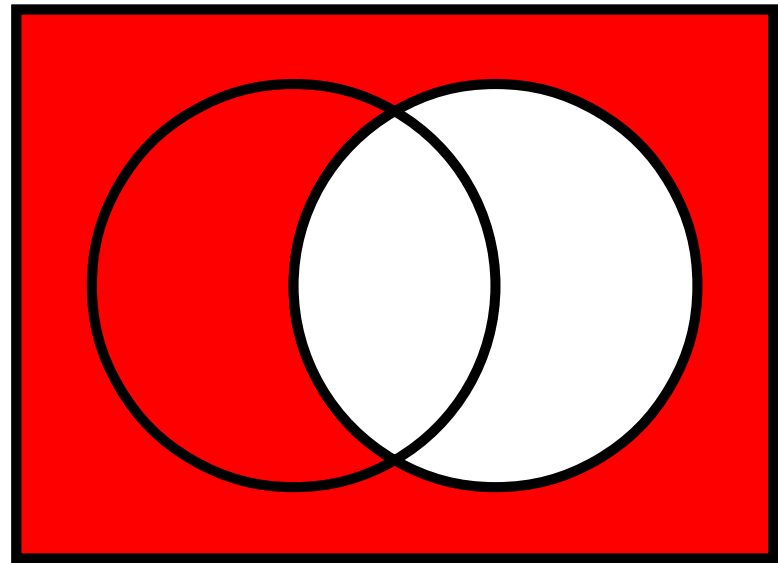

$\bar{L}_2$

# Closure Under Intersection

- If  $L_1$  and  $L_2$  are languages over  $\Sigma$ , then  $L_1 \cap L_2$  is the language of strings in both  $L_1$  and  $L_2$ .
- Question: If  $L_1$  and  $L_2$  are regular, is  $L_1 \cap L_2$  regular as well?

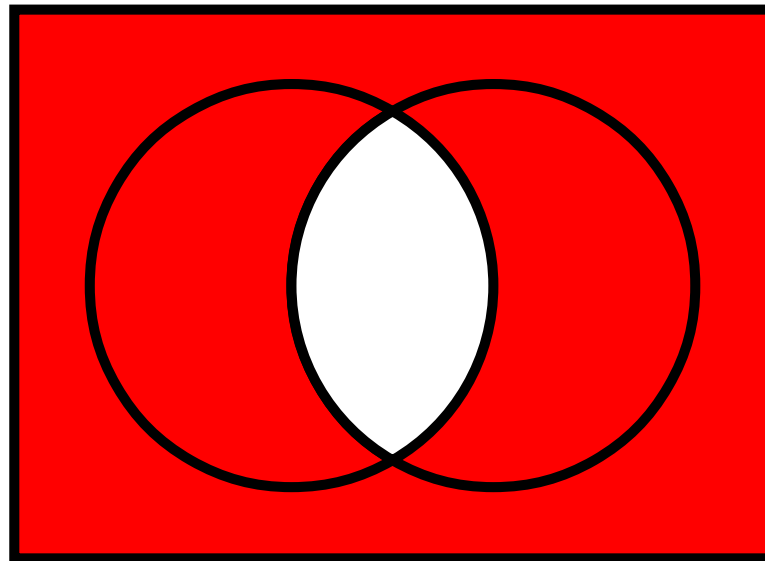

$$\overline{L_1} \cup \overline{L_2}$$

# Closure Under Intersection

- If  $L_1$  and  $L_2$  are languages over  $\Sigma$ , then  $L_1 \cap L_2$  is the language of strings in both  $L_1$  and  $L_2$ .
- Question: If  $L_1$  and  $L_2$  are regular, is  $L_1 \cap L_2$  regular as well?

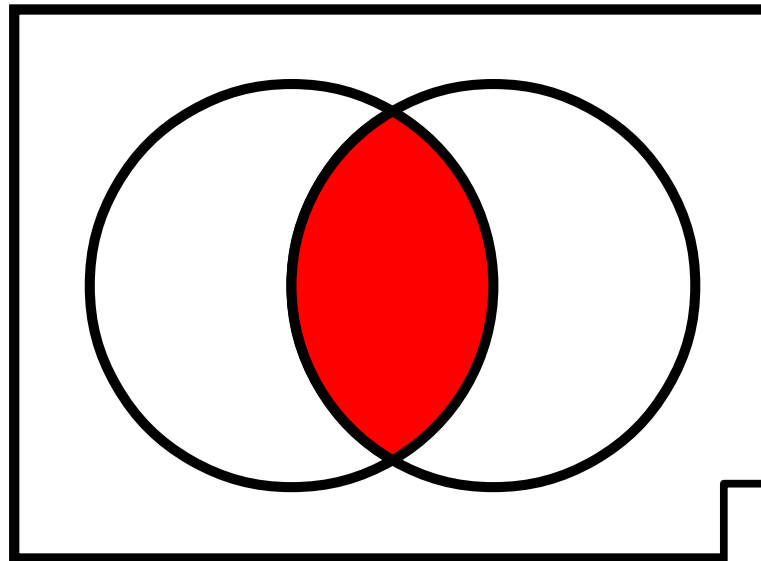

$$\overline{\overline{L_1} \cup \overline{L_2}}$$

Hey, it's De Morgan's laws!

Concatenation

# String Concatenation

- If  $w \in \Sigma^*$  and  $x \in \Sigma^*$ , the **concatenation** of  $w$  and  $x$ , denoted  $wx$ , is the string formed by tacking all the characters of  $x$  onto the end of  $w$ .
- Example: if  $w = \text{quo}$  and  $x = \text{kka}$ , the concatenation  $wx = \text{quokka}$ .
- This is analogous to the  $+$  operator for strings in many programming languages.
- Some facts about concatenation:
  - The empty string  $\varepsilon$  is the **identity element** for concatenation:

$$w\varepsilon = \varepsilon w = w$$

- Concatenation is **associative**:

$$wxy = w(xy) = (wx)y$$

# Concatenation

- The **concatenation** of two languages  $L_1$  and  $L_2$  over the alphabet  $\Sigma$  is the language

$$L_1L_2 = \{ x \mid \exists w_1 \in L_1. \exists w_2 \in L_2. x = w_1w_2 \}$$

- Let  $L_1 = \{ ab, ba \}$  and  $L_2 = \{ aa, bb \}$ . What is  $L_1L_2$ ?

Answer at  
<https://pollev.com/cs103>

# Concatenation Example

- Let  $\Sigma = \{ a, b, \dots, z, A, B, \dots, Z \}$  and consider these languages over  $\Sigma$ :
  - ***Noun*** = { **Puppy, Rainbow, Whale, ...** }
  - ***Verb*** = { **Hugs, Juggles, Loves, ...** }
  - ***The*** = { **The** }
- The language ***TheNounVerbTheNoun*** is
  - { **ThePuppyHugsTheWhale,**  
**TheWhaleLovesTheRainbow,**  
**TheRainbowJugglesTheRainbow, ...** }

# Concatenation

- The **concatenation** of two languages  $L_1$  and  $L_2$  over the alphabet  $\Sigma$  is the language

$$L_1L_2 = \{ x \mid \exists w_1 \in L_1. \exists w_2 \in L_2. x = w_1w_2 \}$$

- Two views of  $L_1L_2$ :
  - The set of all strings that can be made by concatenating a string in  $L_1$  with a string in  $L_2$ .
  - The set of strings that can be split into two pieces: a piece from  $L_1$  and a piece from  $L_2$ .

---

$$L_1 = \{ w \in \{\mathbf{a}, \mathbf{b}\}^* \mid w \text{ has } \textit{odd} \text{ length} \}$$
$$L_2 = \{ w \in \{\mathbf{a}, \mathbf{b}\}^* \mid w \text{ has length exactly three} \}$$

Construct an NFA for  $L_1L_2$ .

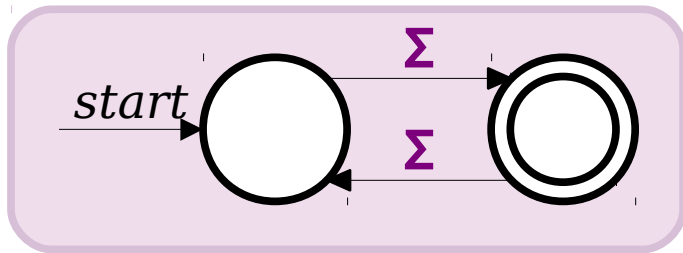

DFA for  $L_1$

---

$$L_1 = \{ w \in \{a, b\}^* \mid w \text{ has odd length} \}$$
$$L_2 = \{ w \in \{a, b\}^* \mid w \text{ has length exactly three} \}$$

Construct an NFA for  $L_1L_2$ .

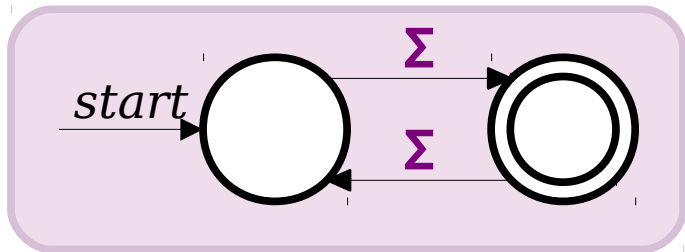

DFA for  $L_1$

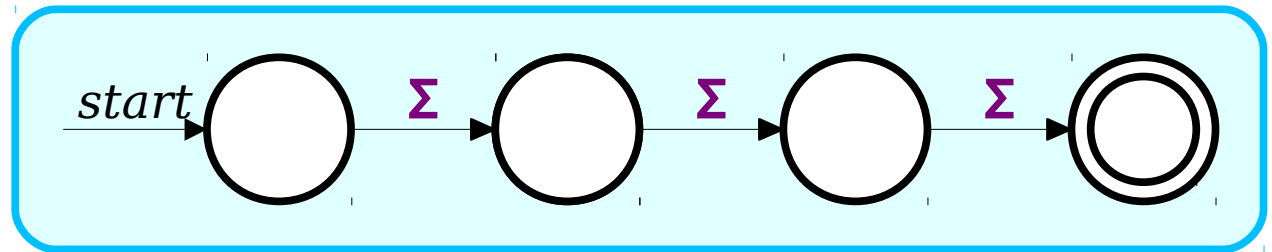

NFA for  $L_2$

$$L_1 = \{ w \in \{ \mathbf{a}, \mathbf{b} \}^* \mid w \text{ has } \textit{odd} \text{ length} \}$$

$$L_2 = \{ w \in \{ \mathbf{a}, \mathbf{b} \}^* \mid w \text{ has length exactly three} \}$$

Construct an NFA for  $L_1L_2$ .

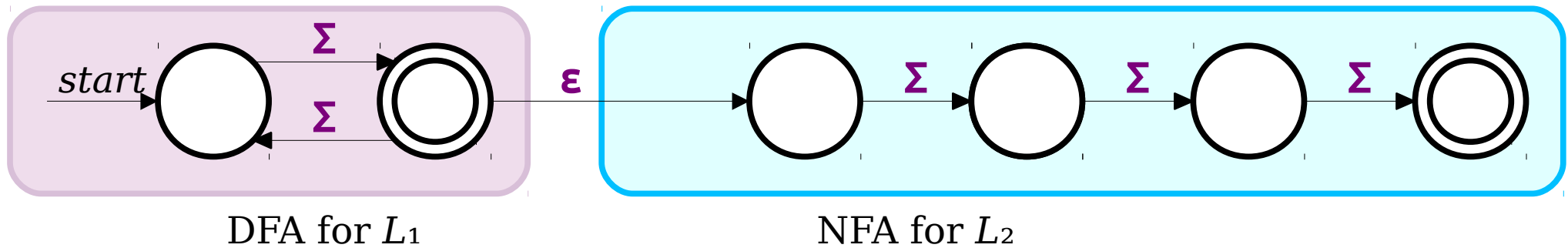

$$L_1 = \{ w \in \{a, b\}^* \mid w \text{ has odd length} \}$$

$$L_2 = \{ w \in \{a, b\}^* \mid w \text{ has length exactly three} \}$$

Construct an NFA for  $L_1L_2$ .

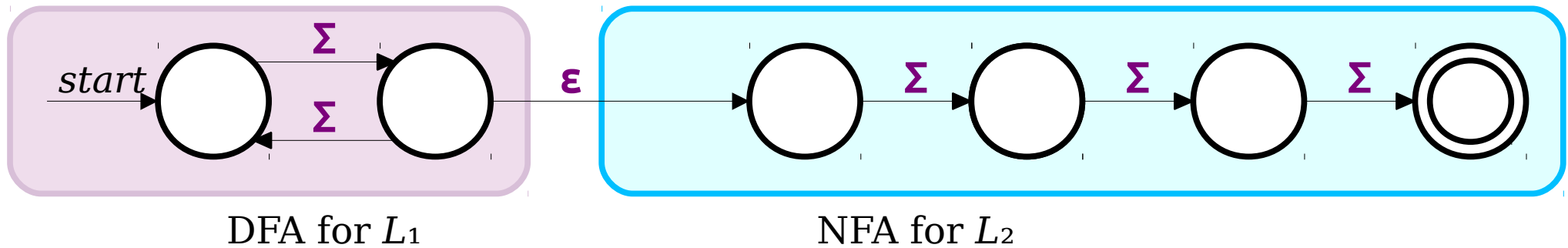

$$L_1 = \{ w \in \{a, b\}^* \mid w \text{ has odd length} \}$$

$$L_2 = \{ w \in \{a, b\}^* \mid w \text{ has length exactly three} \}$$

Construct an NFA for  $L_1L_2$ .

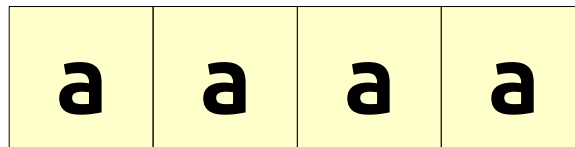
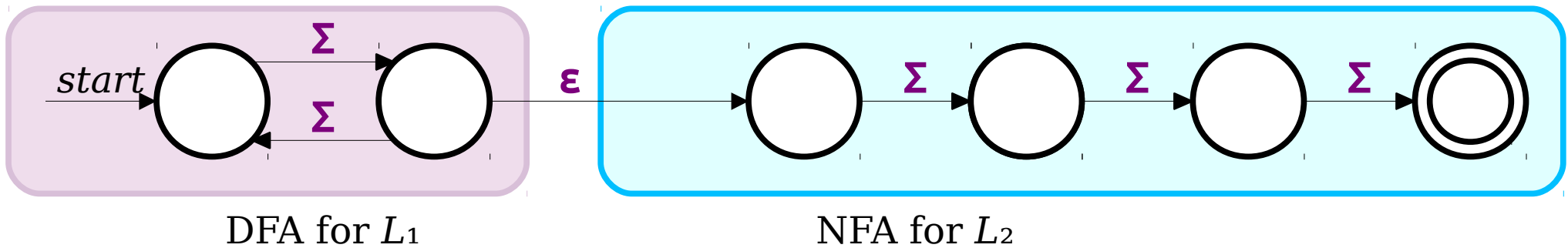

$L_1 = \{ w \in \{a, b\}^* \mid w \text{ has odd length} \}$   
 $L_2 = \{ w \in \{a, b\}^* \mid w \text{ has length exactly three} \}$

Construct an NFA for  $L_1L_2$ .

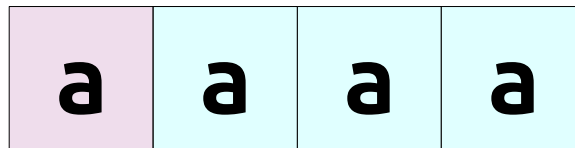
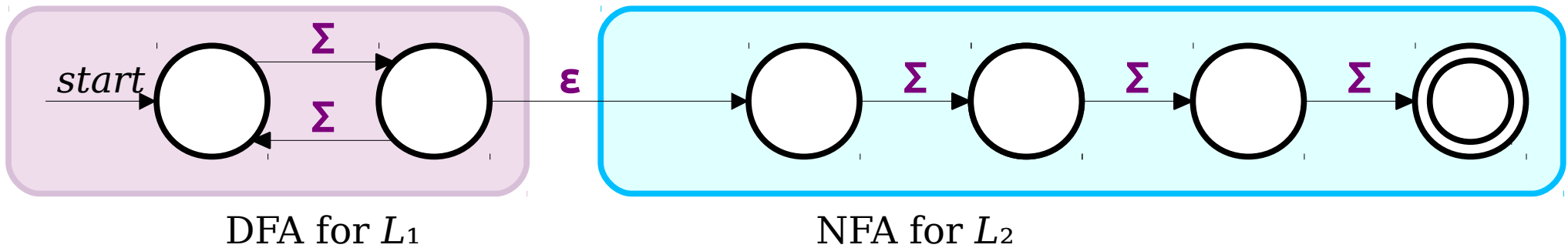

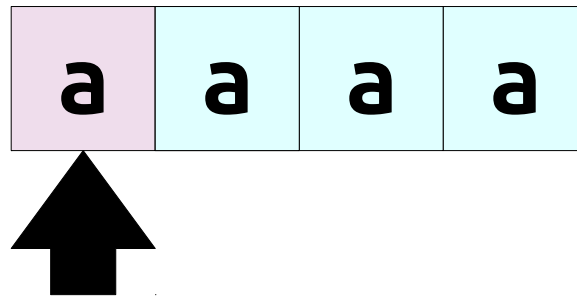
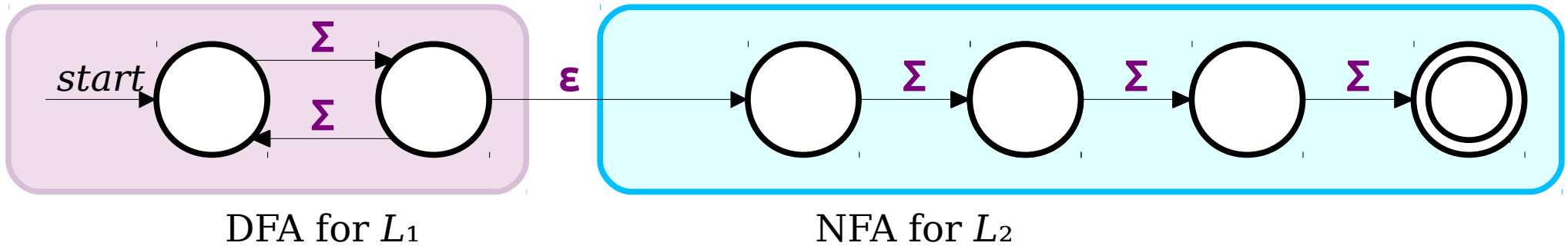

---

$L_1 = \{ w \in \{a, b\}^* \mid w \text{ has odd length} \}$   
 $L_2 = \{ w \in \{a, b\}^* \mid w \text{ has length exactly three} \}$   
 Construct an NFA for  $L_1L_2$ .

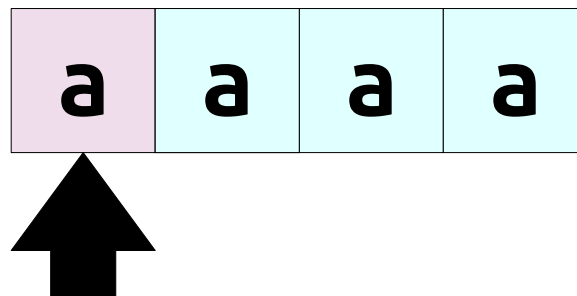
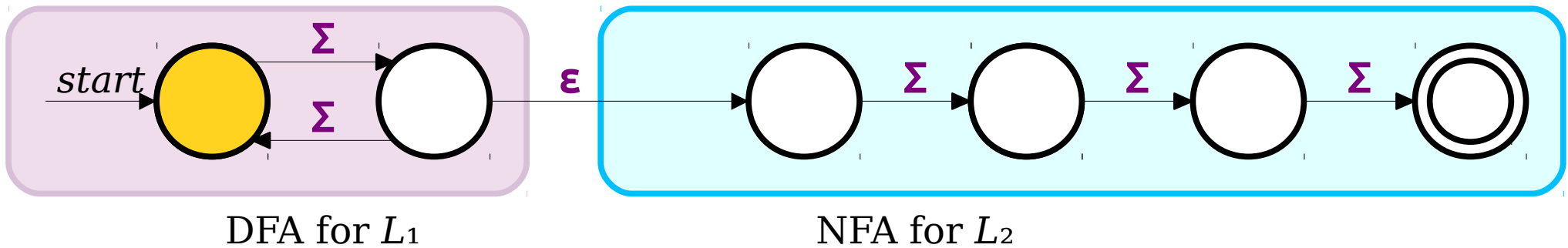

$L_1 = \{ w \in \{a, b\}^* \mid w \text{ has odd length} \}$   
 $L_2 = \{ w \in \{a, b\}^* \mid w \text{ has length exactly three} \}$

Construct an NFA for  $L_1L_2$ .



$L_1 = \{ w \in \{a, b\}^* \mid w \text{ has odd length} \}$   
 $L_2 = \{ w \in \{a, b\}^* \mid w \text{ has length exactly three} \}$

Construct an NFA for  $L_1L_2$ .

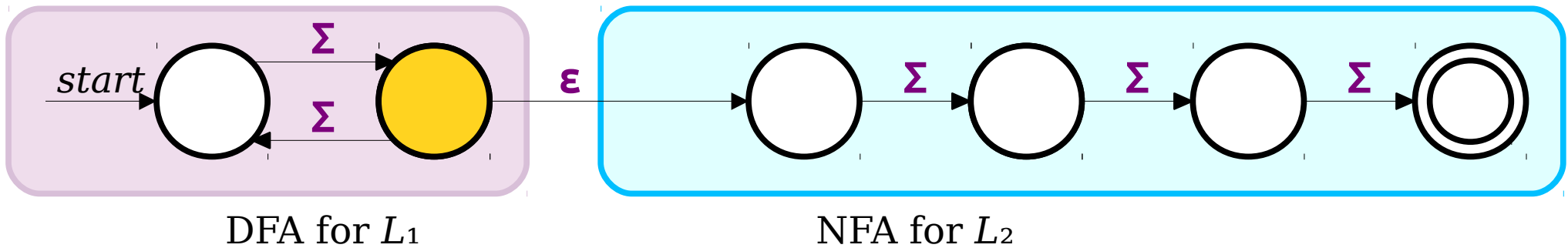

$L_1 = \{ w \in \{a, b\}^* \mid w \text{ has odd length} \}$   
 $L_2 = \{ w \in \{a, b\}^* \mid w \text{ has length exactly three} \}$

Construct an NFA for  $L_1L_2$ .

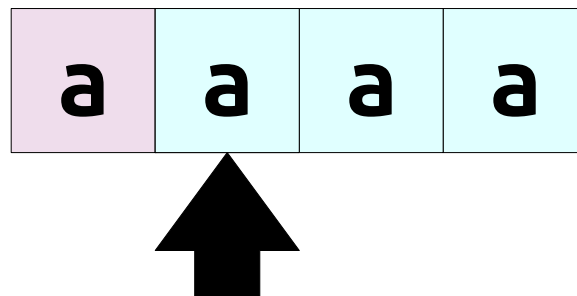
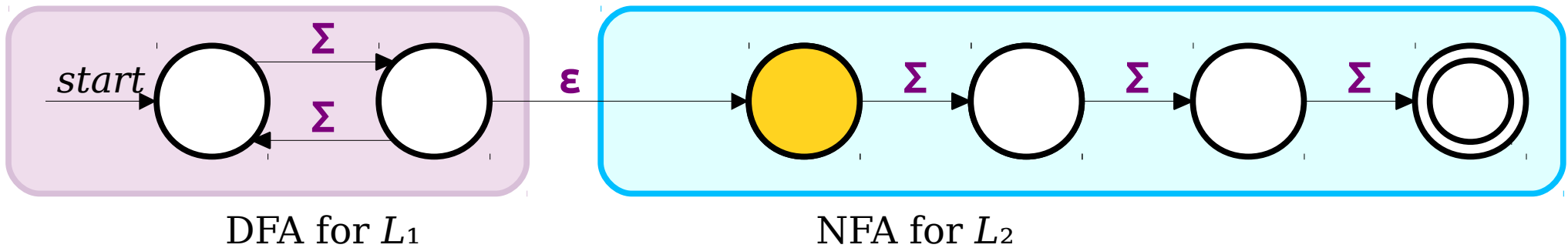

$L_1 = \{ w \in \{a, b\}^* \mid w \text{ has odd length} \}$   
 $L_2 = \{ w \in \{a, b\}^* \mid w \text{ has length exactly three} \}$

Construct an NFA for  $L_1L_2$ .

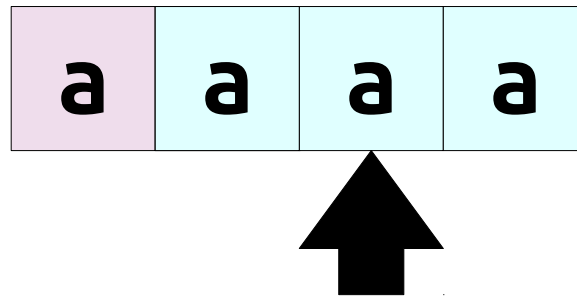
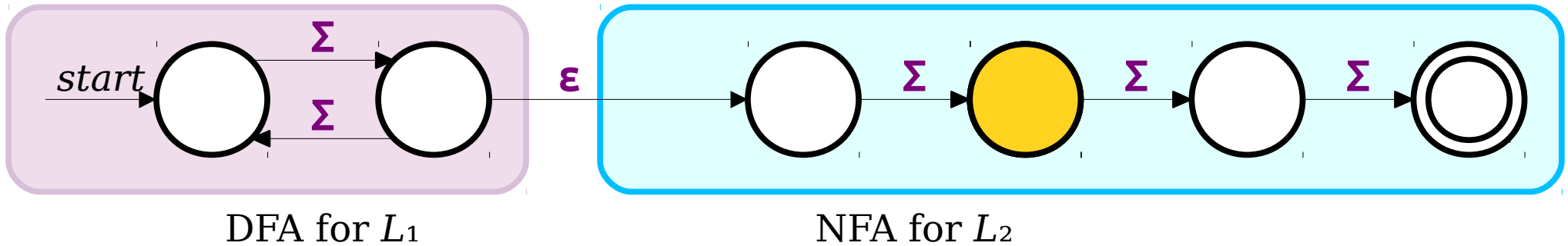

$L_1 = \{ w \in \{a, b\}^* \mid w \text{ has odd length} \}$   
 $L_2 = \{ w \in \{a, b\}^* \mid w \text{ has length exactly three} \}$

Construct an NFA for  $L_1L_2$ .

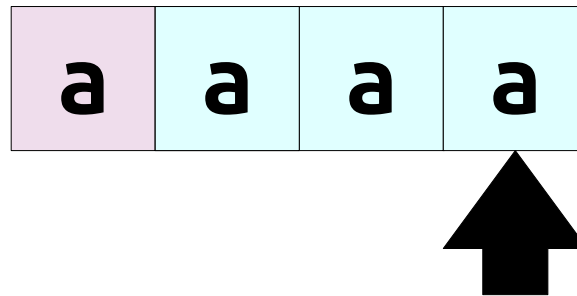
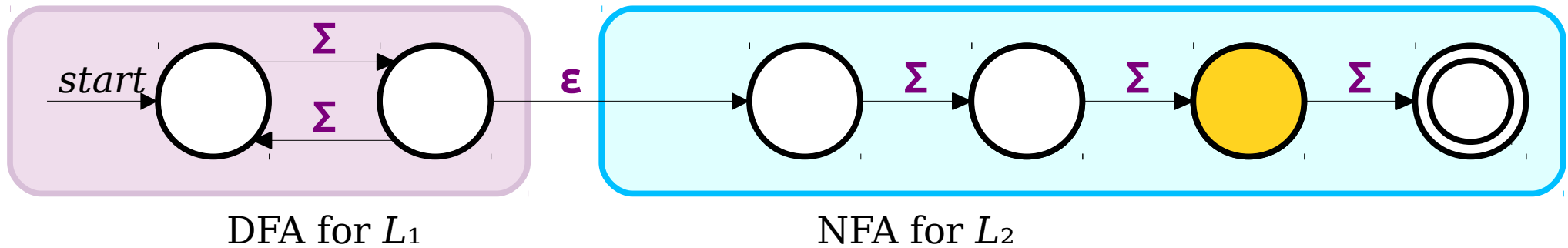

$L_1 = \{ w \in \{a, b\}^* \mid w \text{ has odd length} \}$   
 $L_2 = \{ w \in \{a, b\}^* \mid w \text{ has length exactly three} \}$

Construct an NFA for  $L_1L_2$ .

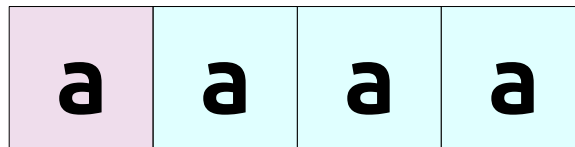
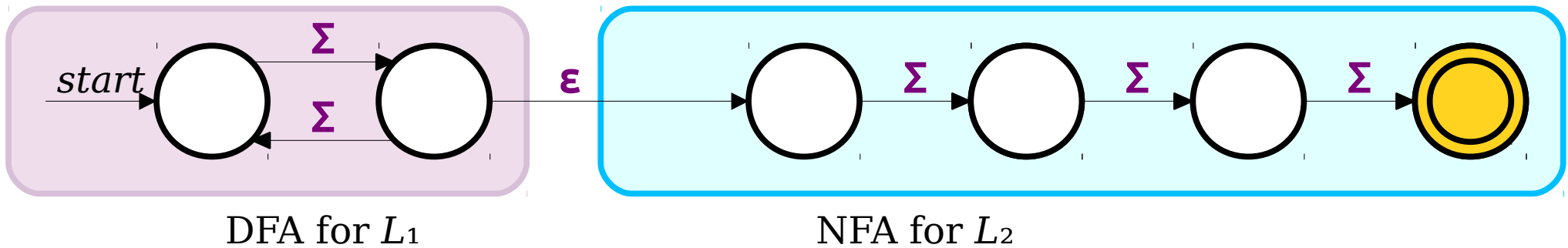

---

$L_1 = \{ w \in \{a, b\}^* \mid w \text{ has odd length} \}$   
 $L_2 = \{ w \in \{a, b\}^* \mid w \text{ has length exactly three} \}$   
 Construct an NFA for  $L_1L_2$ .

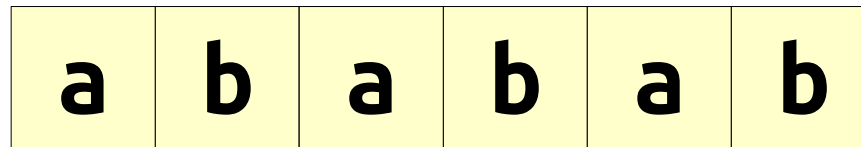
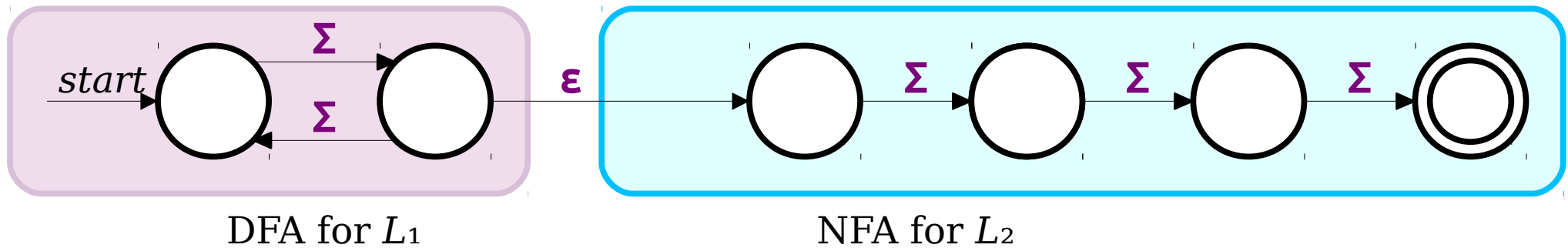

$$L_1 = \{ w \in \{a, b\}^* \mid w \text{ has odd length} \}$$

$$L_2 = \{ w \in \{a, b\}^* \mid w \text{ has length exactly three} \}$$

Construct an NFA for  $L_1L_2$ .

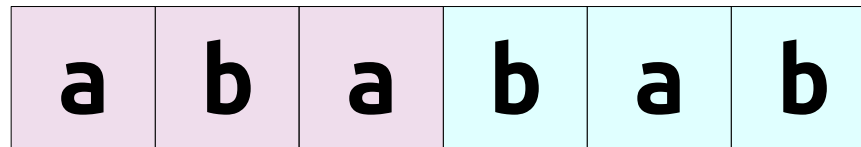
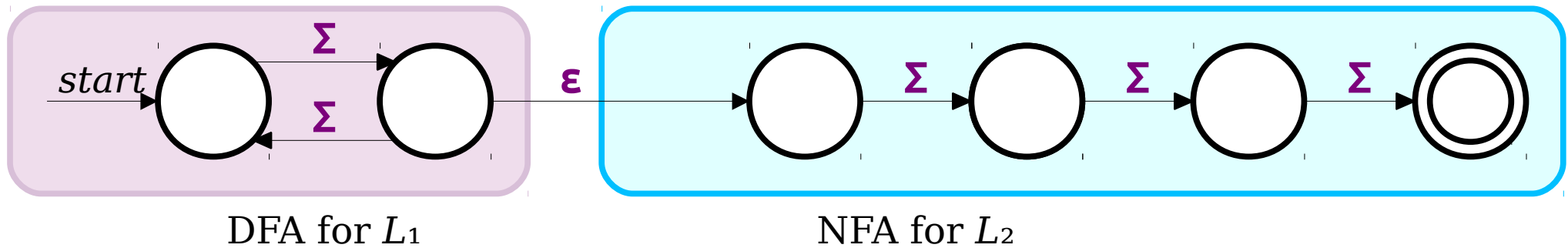

$L_1 = \{ w \in \{a, b\}^* \mid w \text{ has odd length} \}$   
 $L_2 = \{ w \in \{a, b\}^* \mid w \text{ has length exactly three} \}$

Construct an NFA for  $L_1L_2$ .

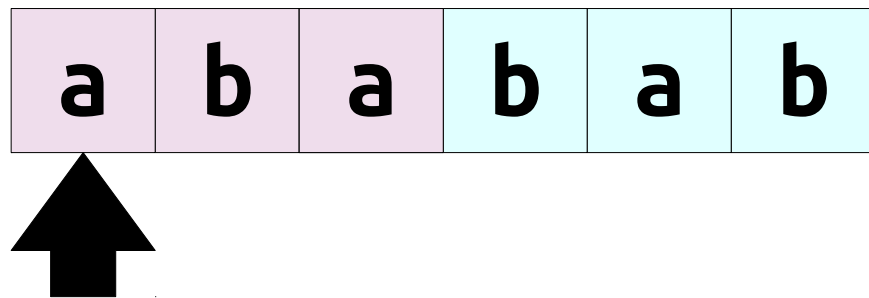
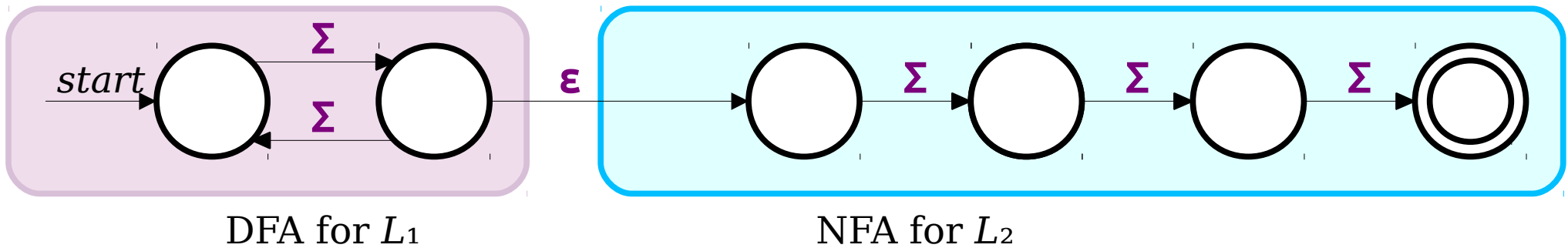

$L_1 = \{ w \in \{a, b\}^* \mid w \text{ has odd length} \}$   
 $L_2 = \{ w \in \{a, b\}^* \mid w \text{ has length exactly three} \}$

Construct an NFA for  $L_1L_2$ .

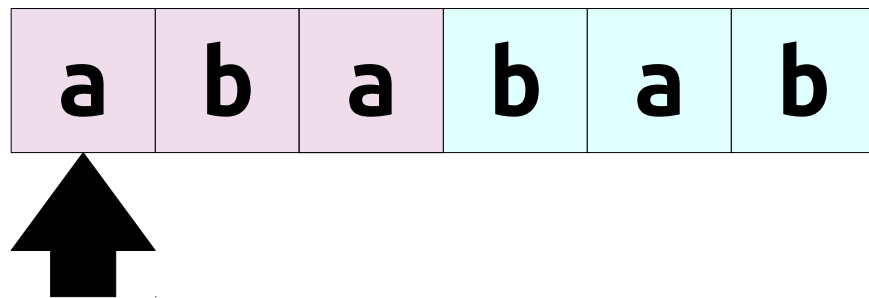
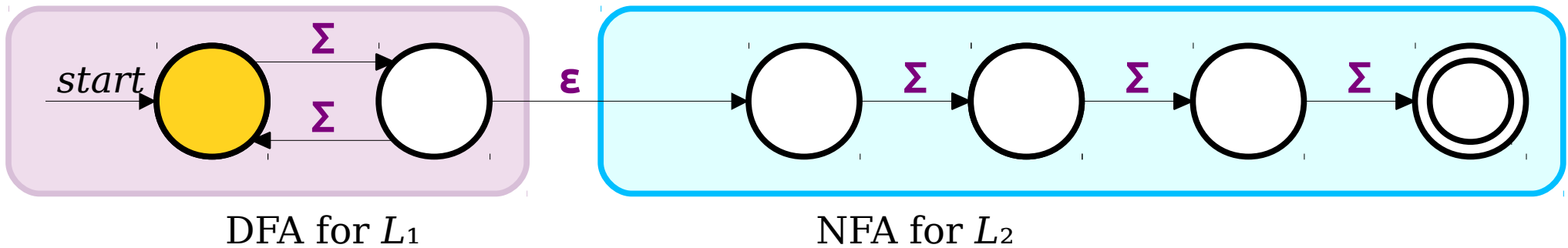

$L_1 = \{ w \in \{a, b\}^* \mid w \text{ has odd length} \}$   
 $L_2 = \{ w \in \{a, b\}^* \mid w \text{ has length exactly three} \}$

Construct an NFA for  $L_1L_2$ .

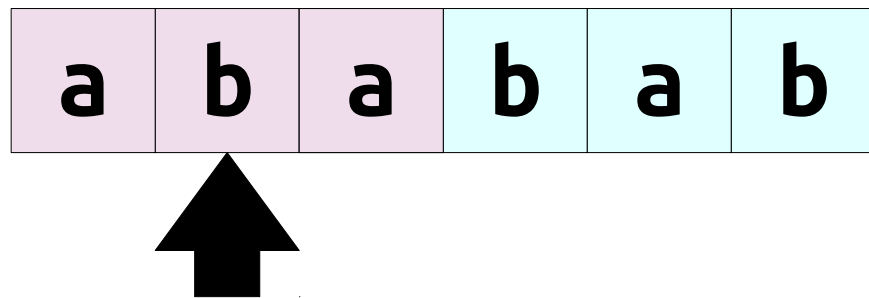
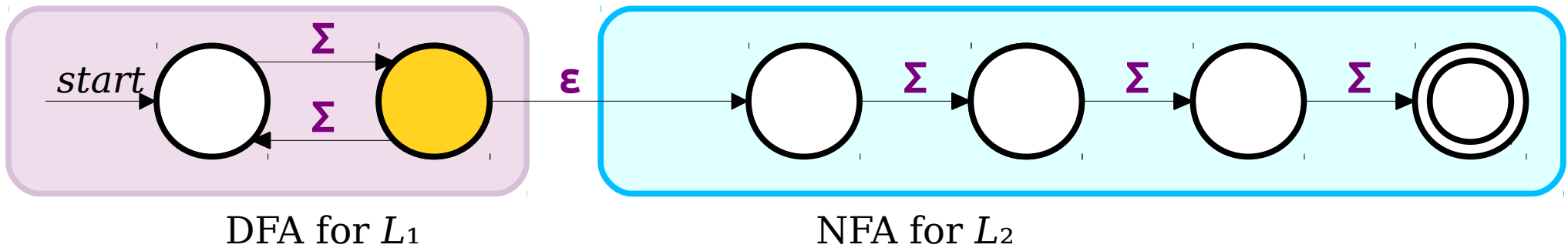

$L_1 = \{ w \in \{a, b\}^* \mid w \text{ has odd length} \}$   
 $L_2 = \{ w \in \{a, b\}^* \mid w \text{ has length exactly three} \}$

Construct an NFA for  $L_1L_2$ .

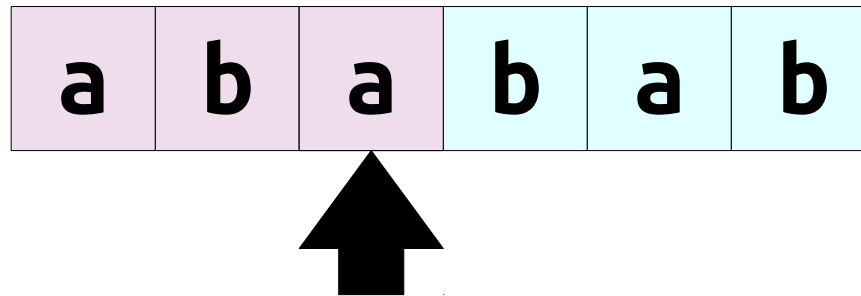
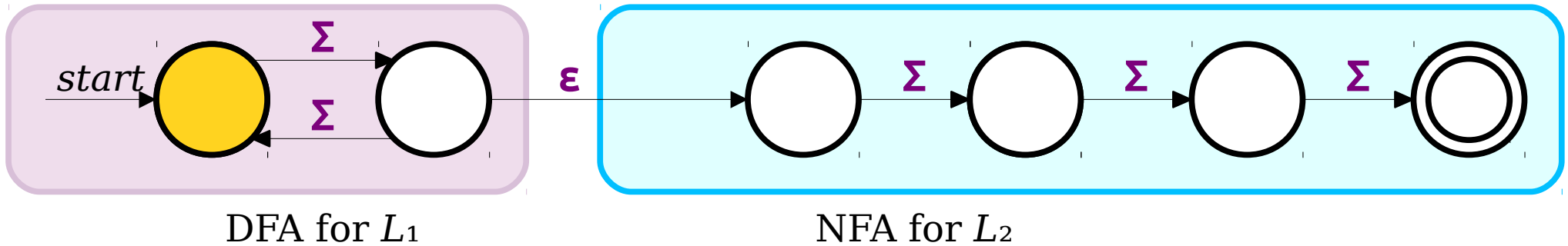

$L_1 = \{ w \in \{a, b\}^* \mid w \text{ has odd length} \}$   
 $L_2 = \{ w \in \{a, b\}^* \mid w \text{ has length exactly three} \}$

Construct an NFA for  $L_1L_2$ .

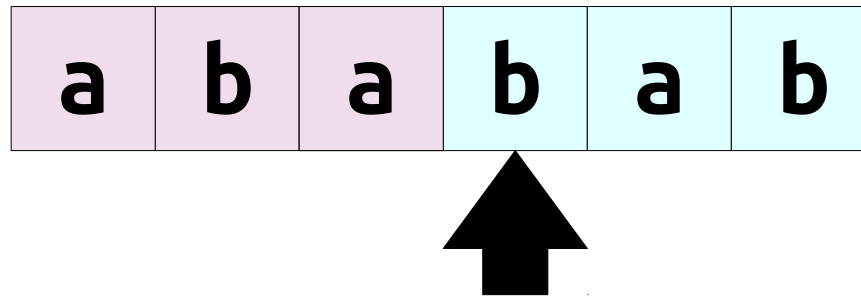
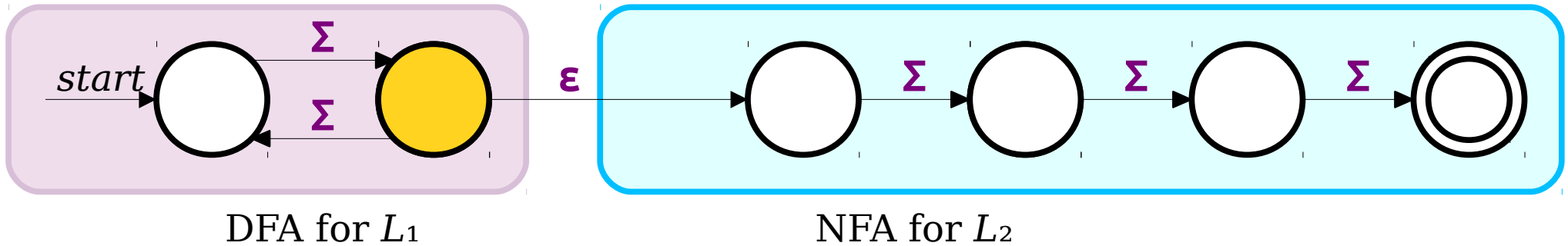

$L_1 = \{ w \in \{a, b\}^* \mid w \text{ has odd length} \}$   
 $L_2 = \{ w \in \{a, b\}^* \mid w \text{ has length exactly three} \}$

Construct an NFA for  $L_1L_2$ .

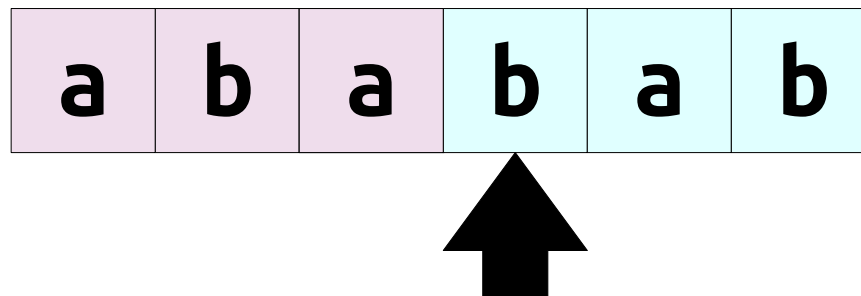
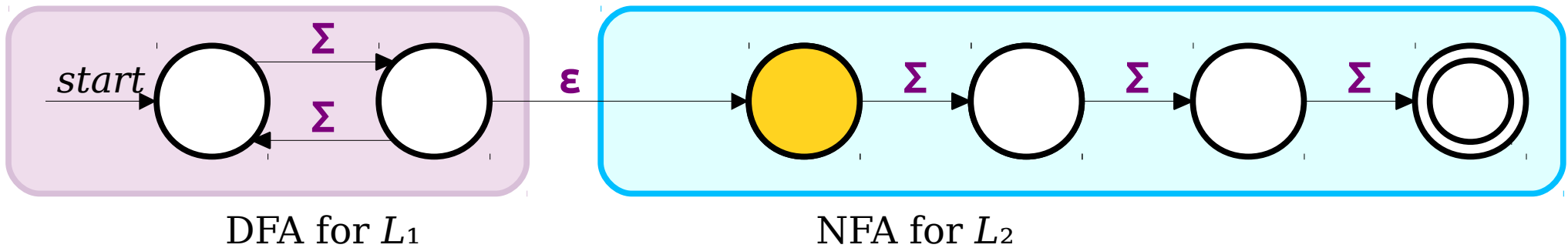

$L_1 = \{ w \in \{a, b\}^* \mid w \text{ has odd length} \}$   
 $L_2 = \{ w \in \{a, b\}^* \mid w \text{ has length exactly three} \}$

Construct an NFA for  $L_1L_2$ .

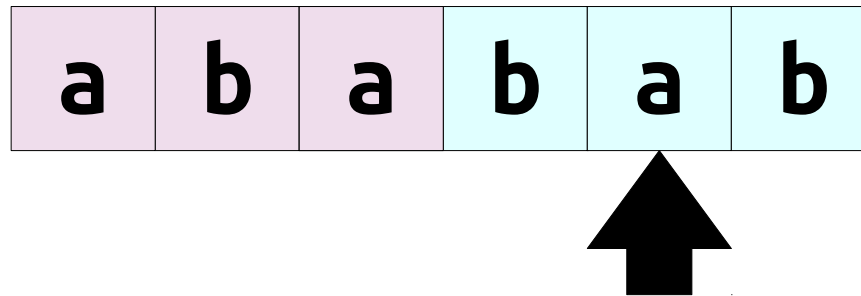
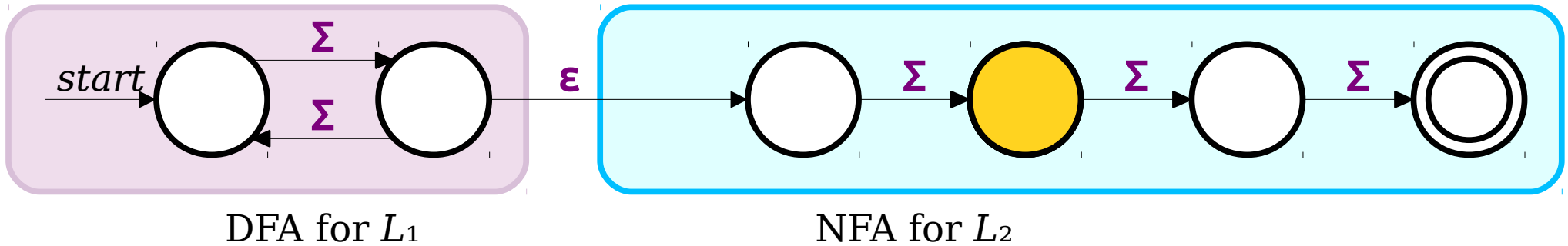

$L_1 = \{ w \in \{a, b\}^* \mid w \text{ has } \textit{odd} \text{ length} \}$   
 $L_2 = \{ w \in \{a, b\}^* \mid w \text{ has length exactly three} \}$

Construct an NFA for  $L_1L_2$ .

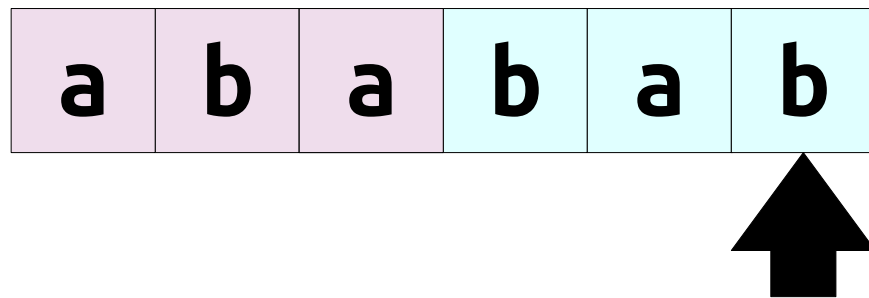
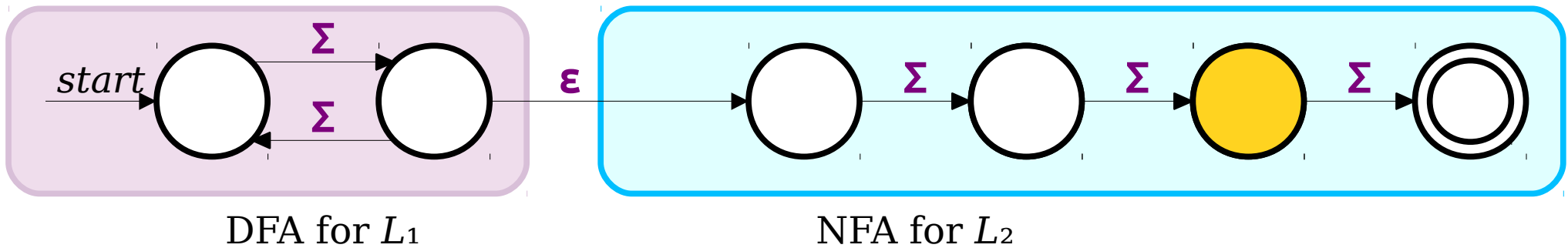

$L_1 = \{ w \in \{a, b\}^* \mid w \text{ has odd length} \}$   
 $L_2 = \{ w \in \{a, b\}^* \mid w \text{ has length exactly three} \}$

Construct an NFA for  $L_1L_2$ .

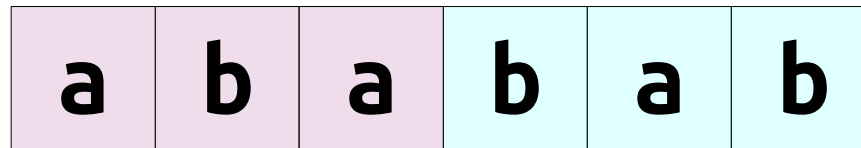
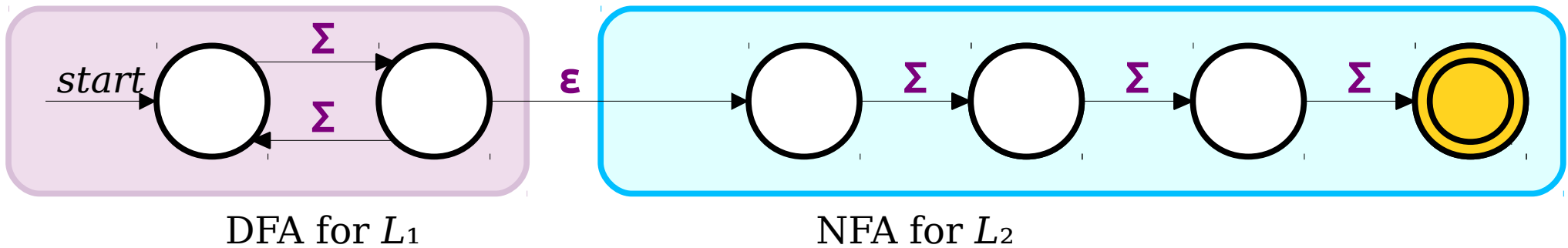

$L_1 = \{ w \in \{a, b\}^* \mid w \text{ has odd length} \}$   
 $L_2 = \{ w \in \{a, b\}^* \mid w \text{ has length exactly three} \}$

Construct an NFA for  $L_1L_2$ .

# Lots and Lots of Concatenation

- Consider the language  $L = \{ \mathbf{aa}, \mathbf{b} \}$
- $LL$  is the set of strings formed by concatenating pairs of strings in  $L$ .

$\{ \mathbf{aaaa}, \mathbf{aab}, \mathbf{baa}, \mathbf{bb} \}$

- $LLL$  is the set of strings formed by concatenating triples of strings in  $L$ .

$\{ \mathbf{aaaaaa}, \mathbf{aaaab}, \mathbf{aabaa}, \mathbf{aabb}, \mathbf{baaaa}, \mathbf{baab}, \mathbf{bbaa}, \mathbf{bbb} \}$

- $LLLL$  is the set of strings formed by concatenating quadruples of strings in  $L$ .

$\{ \mathbf{aaaaaaaa}, \mathbf{aaaaaab}, \mathbf{aaaabaa}, \mathbf{aaaabb}, \mathbf{aabaaaa}, \mathbf{aabaab}, \mathbf{aabbaa}, \mathbf{aabbb}, \mathbf{baaaaaa}, \mathbf{baaaab}, \mathbf{baabaa}, \mathbf{baabb}, \mathbf{bbaaaa}, \mathbf{bbaab}, \mathbf{bbbaa}, \mathbf{bbbb} \}$

# Language Exponentiation

- We can define what it means to “exponentiate” a language as follows:
- $L^0 = \{\varepsilon\}$ 
  - Intuition: The only string you can form by gluing no strings together is the empty string.
  - Notice that  $\{\varepsilon\} \neq \emptyset$ . Can you explain why?
- $L^{n+1} = LL^n$ 
  - Idea: Concatenating  $(n+1)$  strings together works by concatenating  $n$  strings, then concatenating one more.
- **Question to ponder:** Why define  $L^0 = \{\varepsilon\}$ ?
- **Question to ponder:** What is  $\emptyset^0$ ?

The Kleene Star

# The Kleene Closure

- An important operation on languages is the ***Kleene closure***, or ***Kleene star***, which is defined as

$$L^* = \{ w \in \Sigma^* \mid \exists n \in \mathbb{N}. w \in L^n \}$$

- Mathematically:

$$w \in L^* \quad \leftrightarrow \quad \exists n \in \mathbb{N}. w \in L^n$$

- Intuitively,  $L^*$  is the language all possible ways of concatenating zero or more strings in  $L$  together, possibly with repetition.
- ***Question to ponder:*** What is  $\emptyset^*$ ?

# The Kleene Closure

If  $L = \{ \mathbf{a}, \mathbf{bb} \}$ , then  $L^* = \{$

$\epsilon,$

$\mathbf{a}, \mathbf{bb},$

$\mathbf{aa}, \mathbf{abb}, \mathbf{bba}, \mathbf{bbbb},$

$\mathbf{aaa}, \mathbf{aabb}, \mathbf{abba}, \mathbf{abbbb}, \mathbf{bbaa}, \mathbf{bbabb}, \mathbf{bbbba}, \mathbf{bbbbbb},$

$\dots$

$\}$

Think of  $L^*$  as the set of strings you can make if you have a collection of stamps - one for each string in  $L$  - and you form every possible string that can be made from those stamps.

***Idea:*** Can we convert an NFA for a language  $L$  to an NFA for language  $L^*$ ?

---

$L = \{ w \in \{a, b\}^* \mid w \text{ has an odd number of } a\text{'s and an even number of } b\text{'s} \}$

Construct an NFA for  $L^*$ .

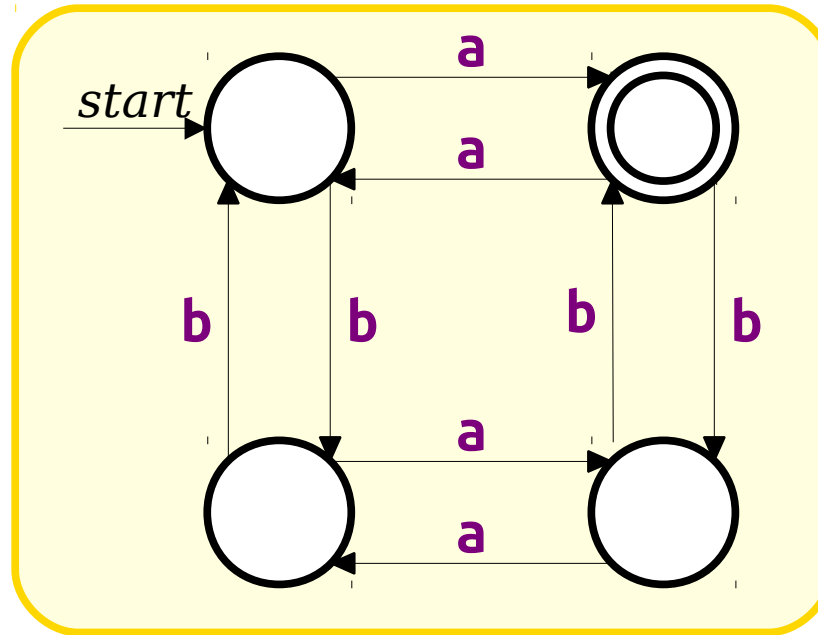

DFA for  $L$

$L = \{ w \in \{a, b\}^* \mid w \text{ has an odd number of } a\text{'s and an even number of } b\text{'s} \}$

Construct an NFA for  $L^*$ .

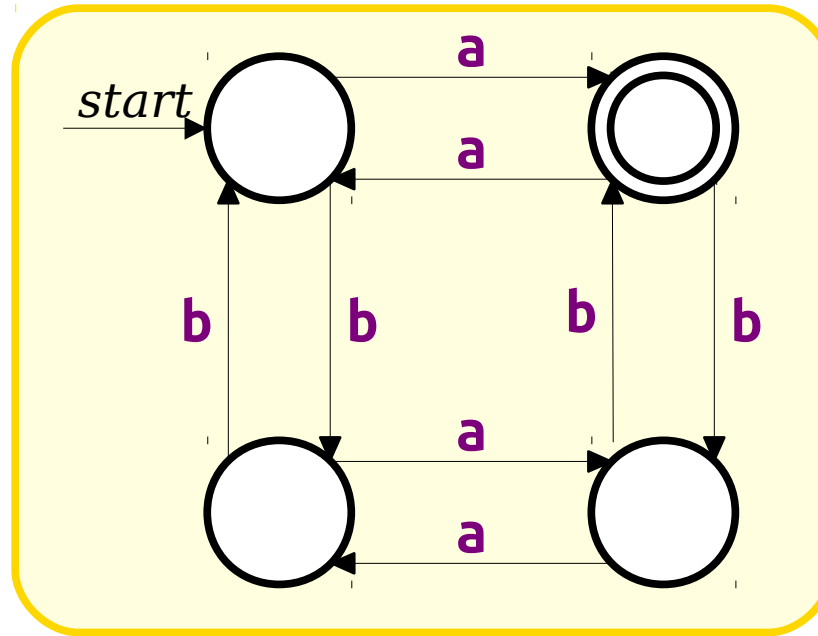
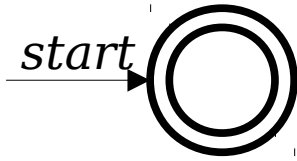

DFA for  $L$

$L = \{ w \in \{a, b\}^* \mid w \text{ has an odd number of } a\text{'s and an even number of } b\text{'s} \}$

Construct an NFA for  $L^*$ .

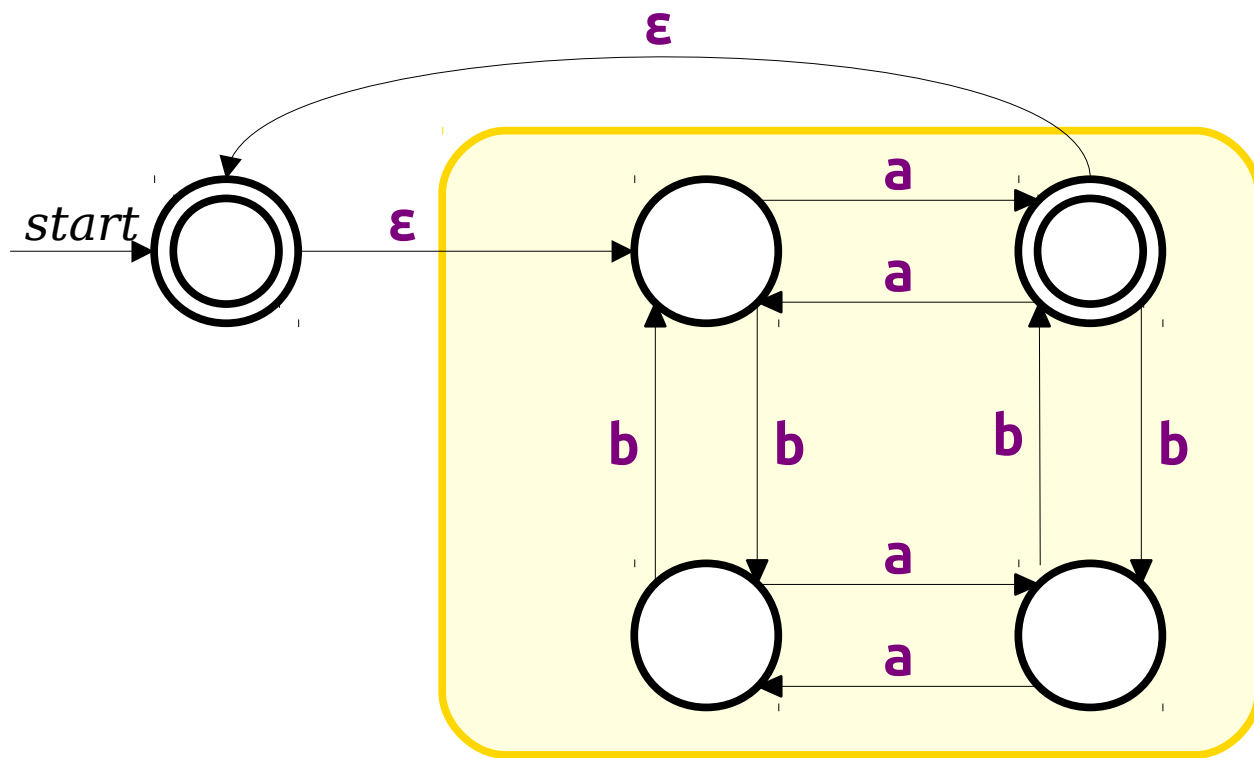

DFA for  $L$

$L = \{ w \in \{a, b\}^* \mid w \text{ has an odd number of } a\text{'s and an even number of } b\text{'s} \}$

Construct an NFA for  $L^*$ .

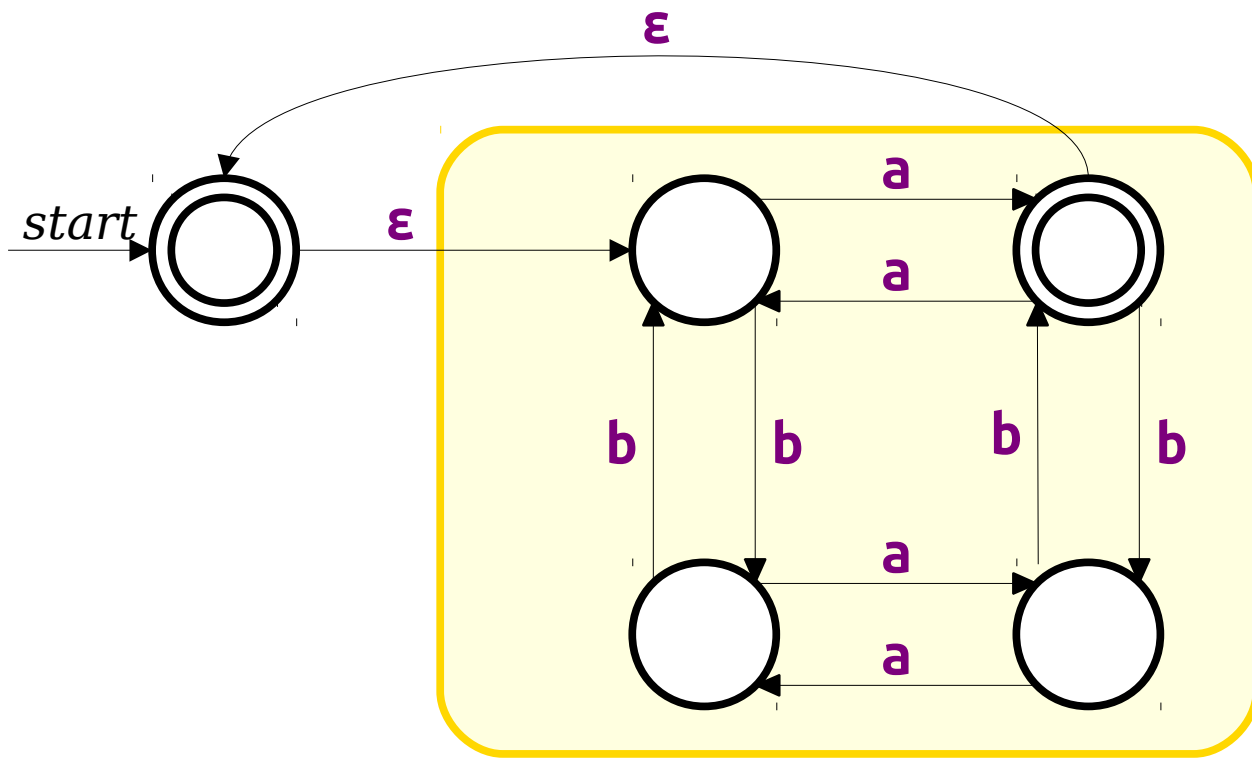

DFA for  $L$

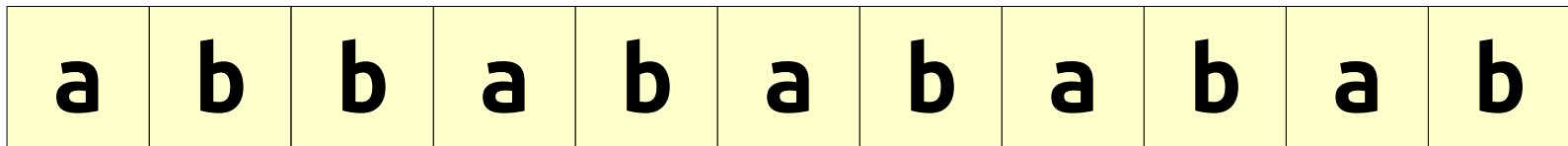

$L = \{ w \in \{a, b\}^* \mid w \text{ has an odd number of } a\text{'s and an even number of } b\text{'s} \}$

Construct an NFA for  $L^*$ .

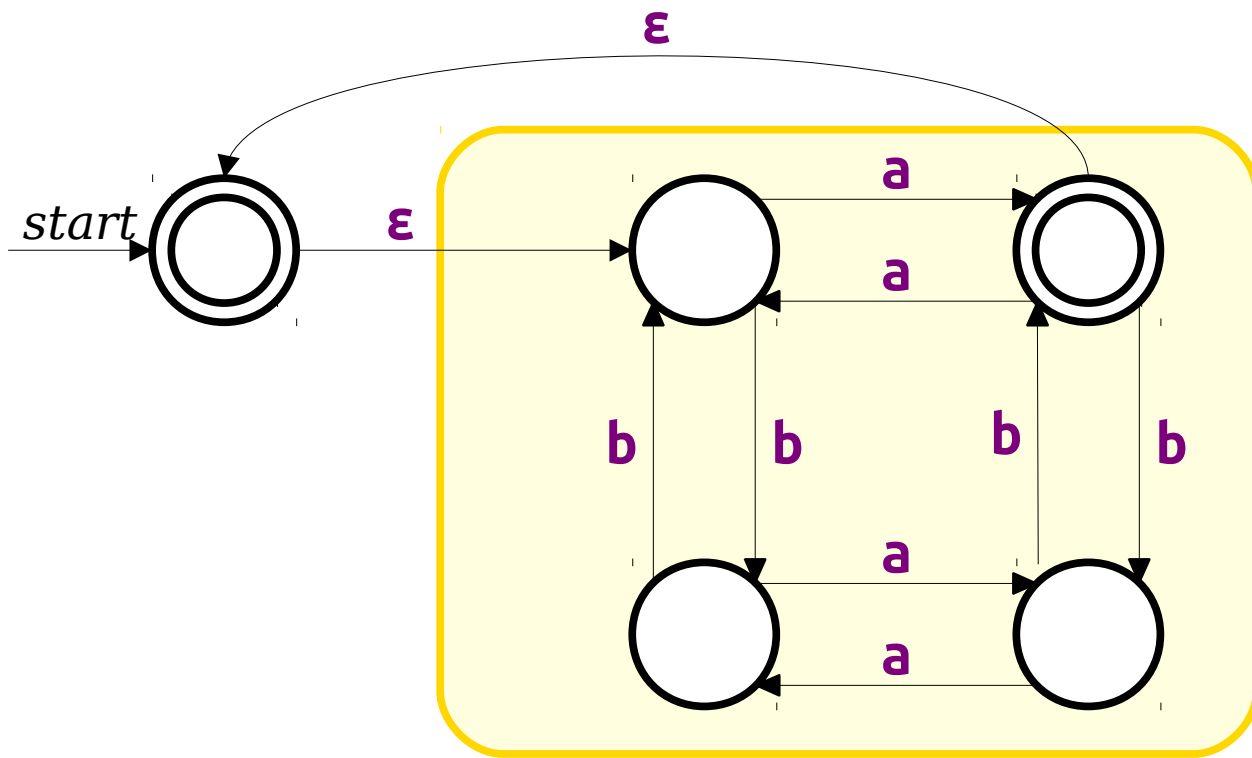

DFA for  $L$

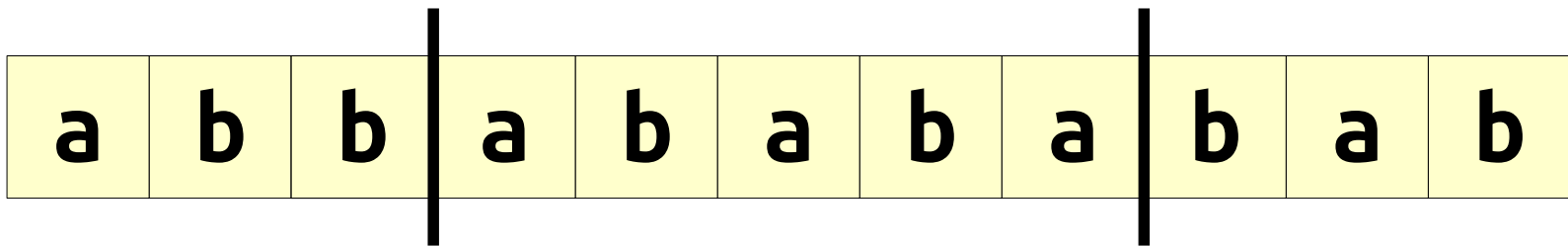

$L = \{ w \in \{a, b\}^* \mid w \text{ has an odd number of } a\text{'s and an even number of } b\text{'s} \}$

Construct an NFA for  $L^*$ .

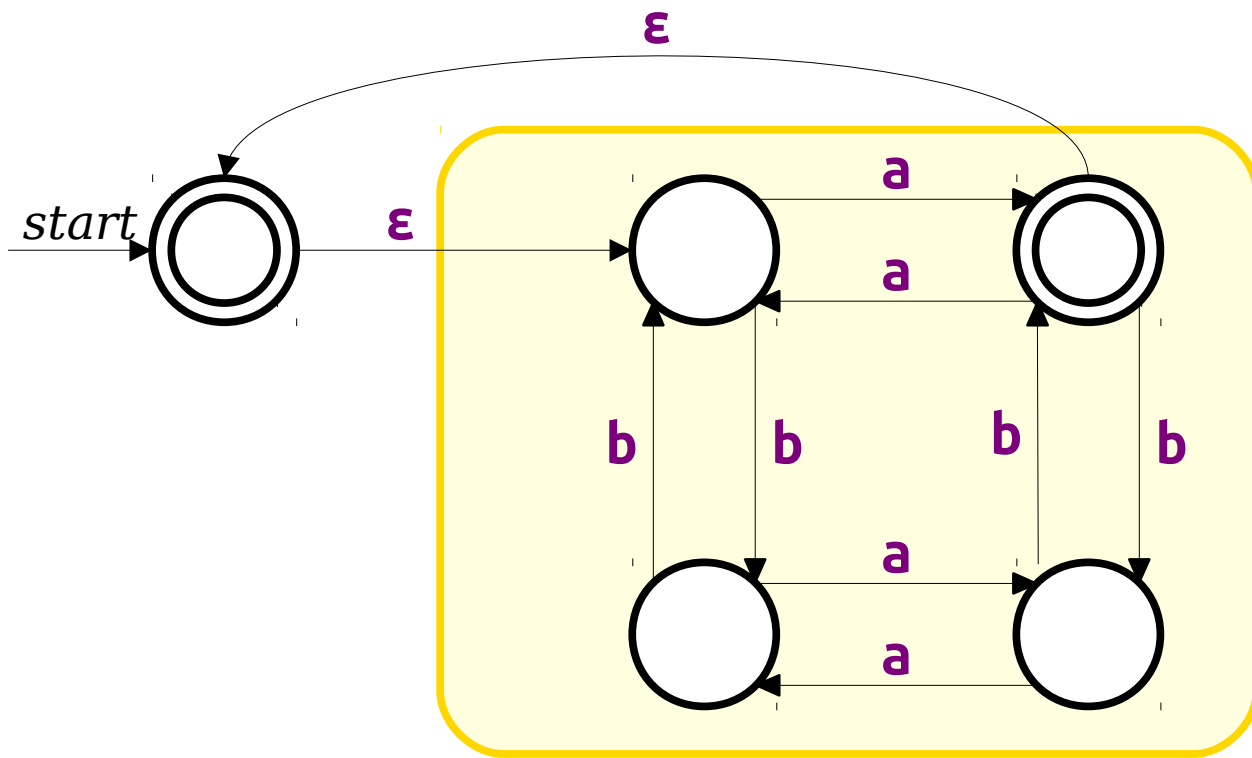

DFA for  $L$

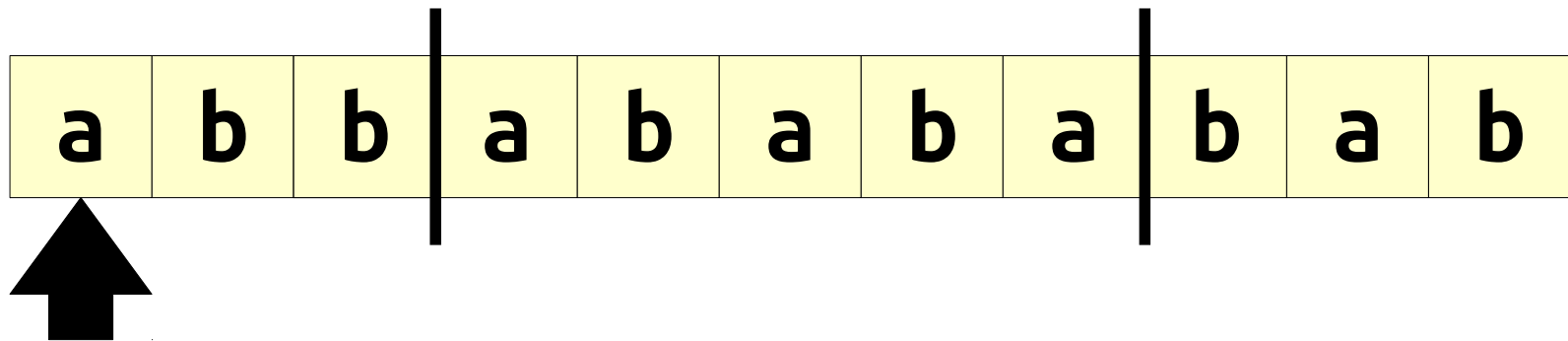

$L = \{ w \in \{a, b\}^* \mid w \text{ has an odd number of } a\text{'s and an even number of } b\text{'s} \}$

Construct an NFA for  $L^*$ .

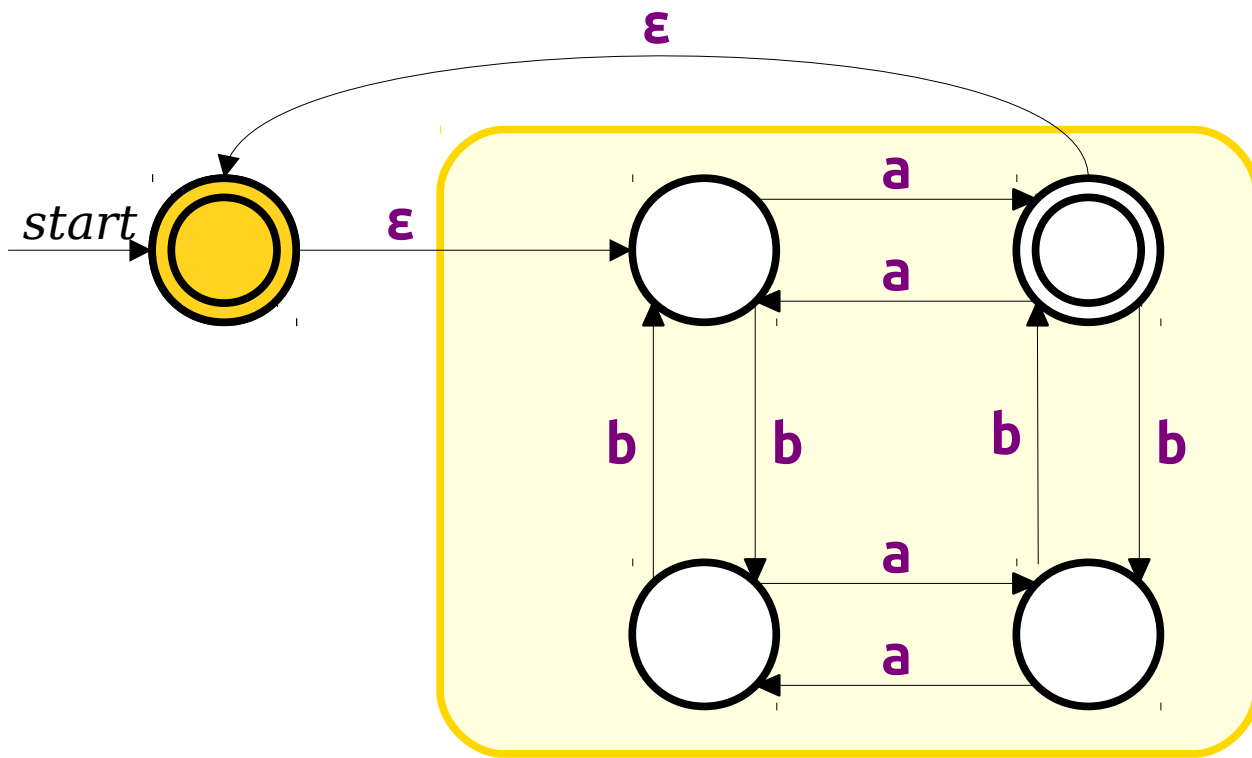

DFA for  $L$

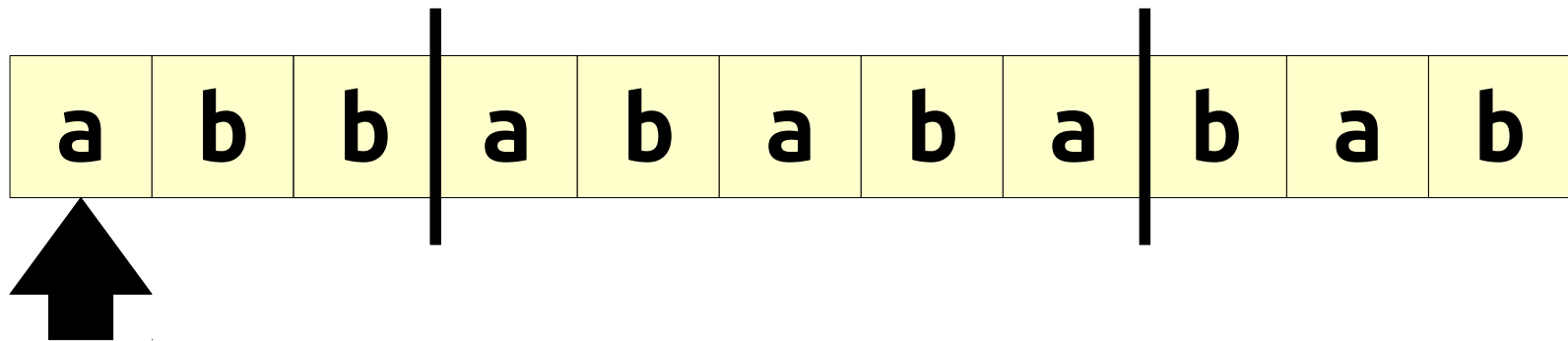

$L = \{ w \in \{a, b\}^* \mid w \text{ has an odd number of } a\text{'s and an even number of } b\text{'s} \}$

Construct an NFA for  $L^*$ .

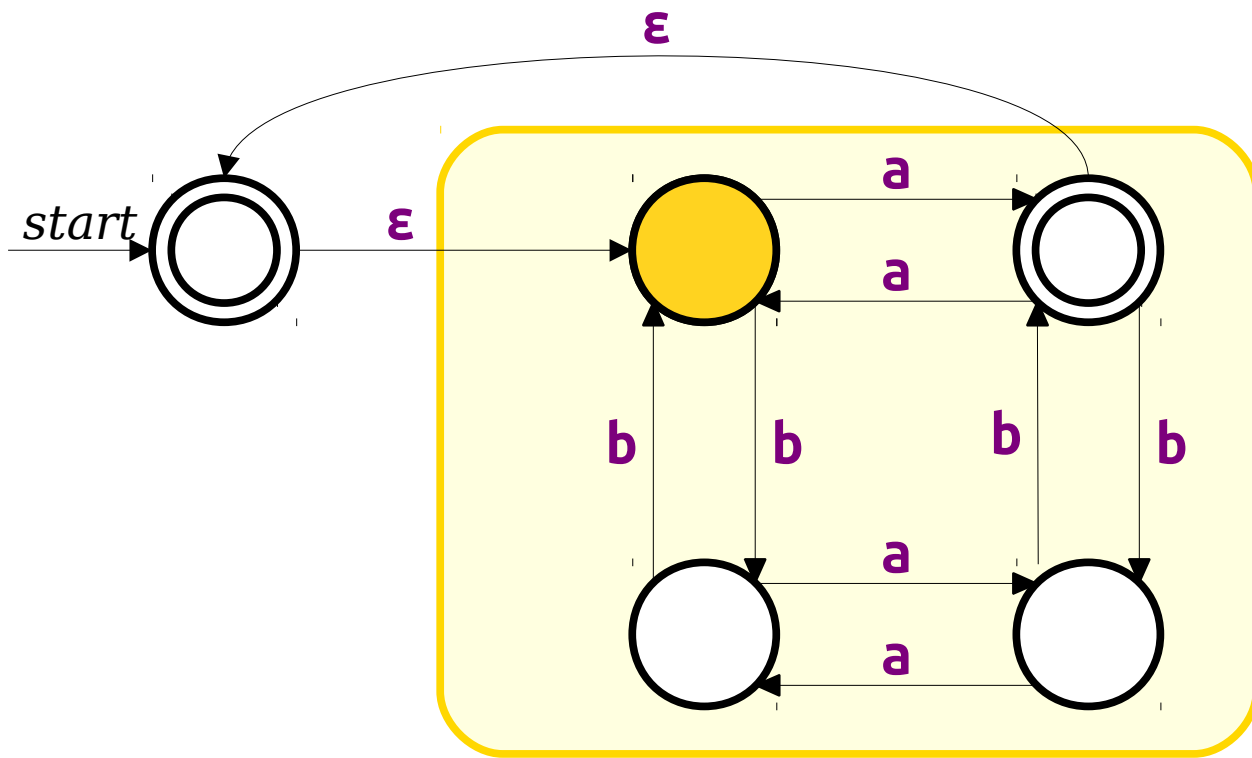

DFA for  $L$

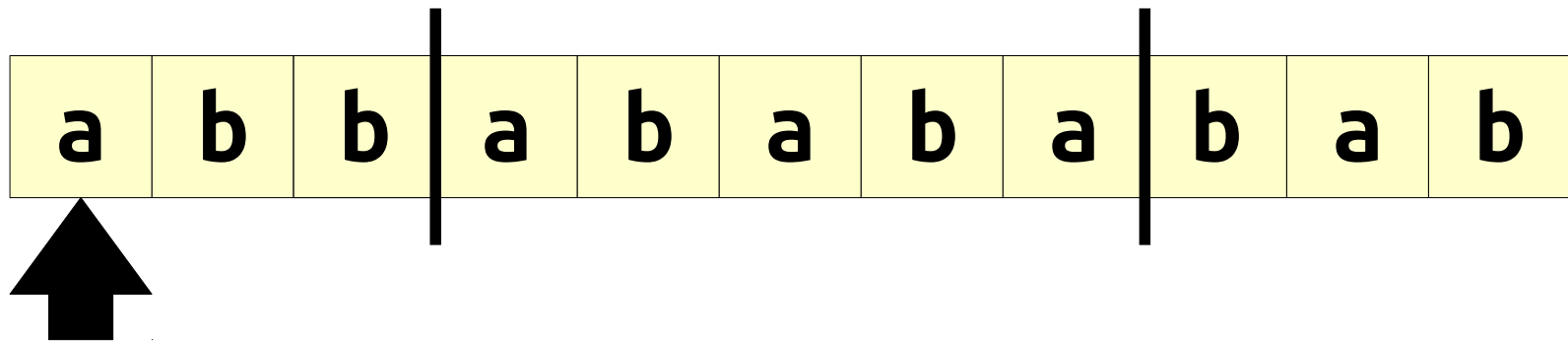

$L = \{ w \in \{a, b\}^* \mid w \text{ has an odd number of } a\text{'s and an even number of } b\text{'s} \}$

Construct an NFA for  $L^*$ .

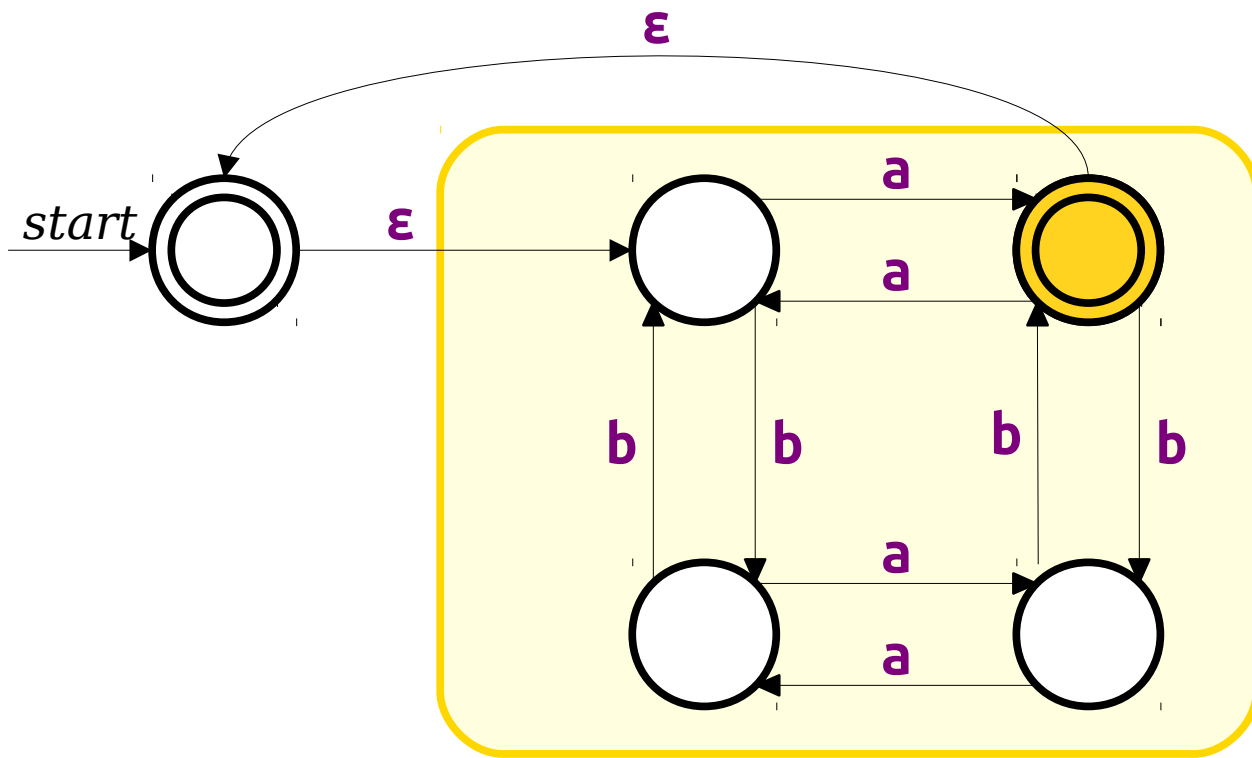

DFA for  $L$

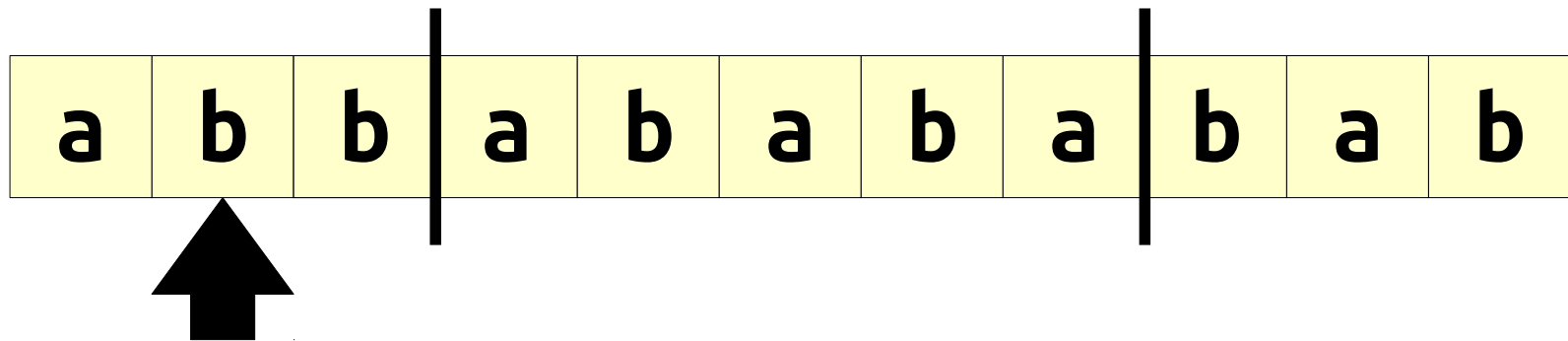

$L = \{ w \in \{a, b\}^* \mid w \text{ has an odd number of } a\text{'s and an even number of } b\text{'s} \}$

Construct an NFA for  $L^*$ .

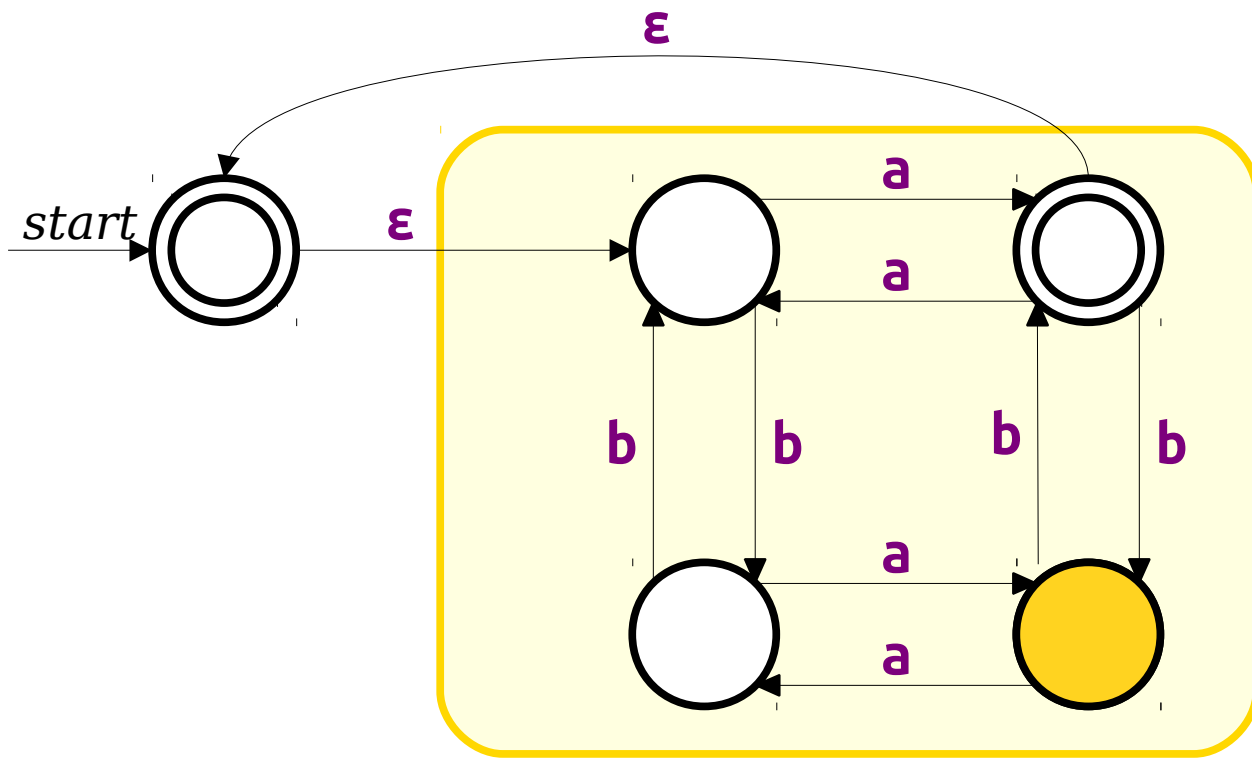

DFA for  $L$

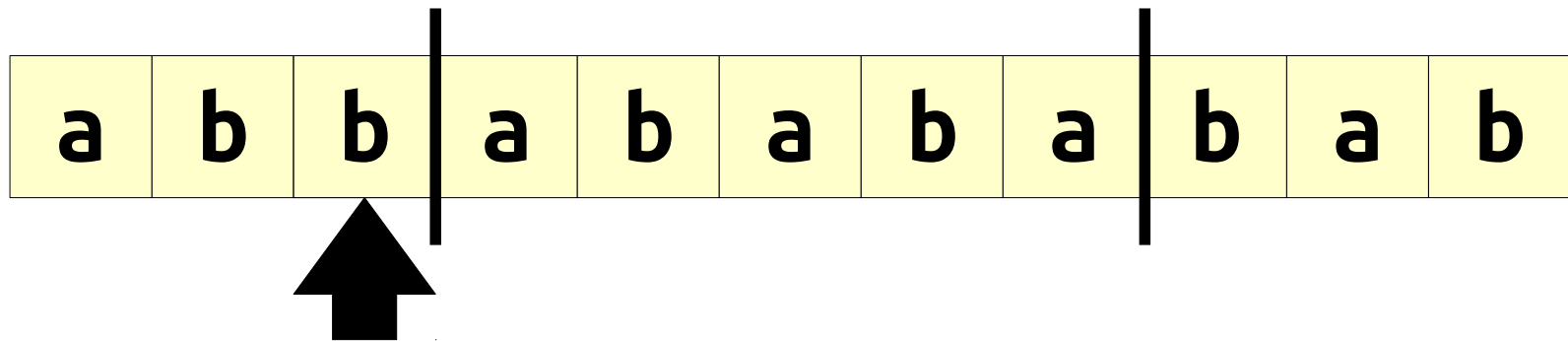

$L = \{ w \in \{a, b\}^* \mid w \text{ has an odd number of } a\text{'s and an even number of } b\text{'s} \}$

Construct an NFA for  $L^*$ .

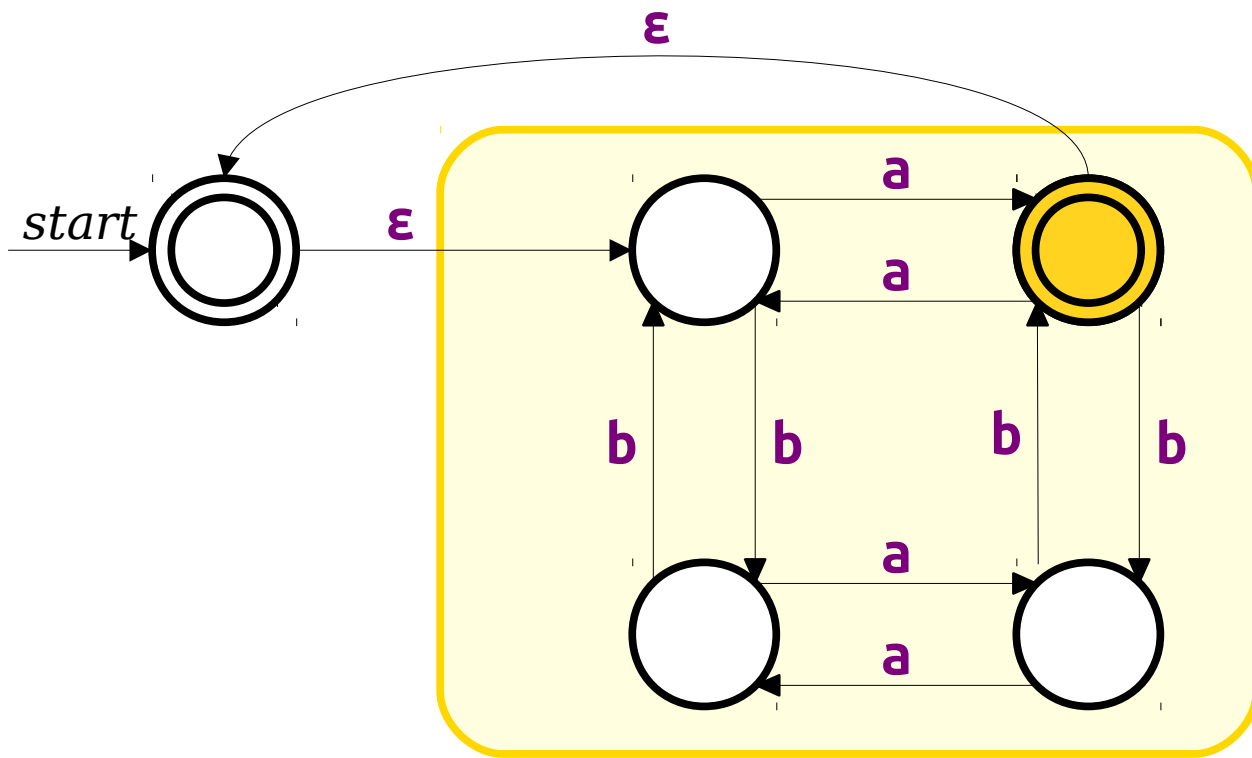

DFA for  $L$

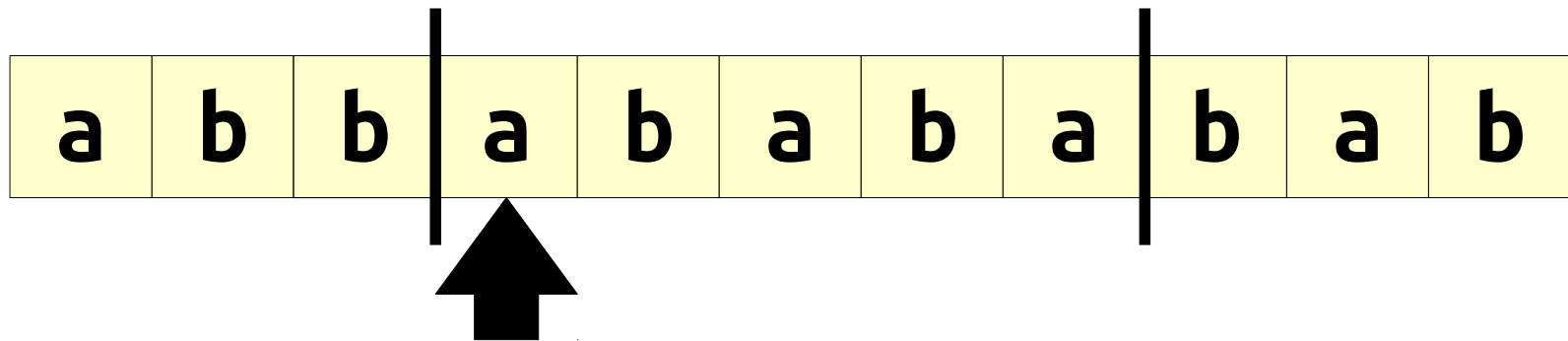

$L = \{ w \in \{a, b\}^* \mid w \text{ has an odd number of } a\text{'s and an even number of } b\text{'s} \}$

Construct an NFA for  $L^*$ .

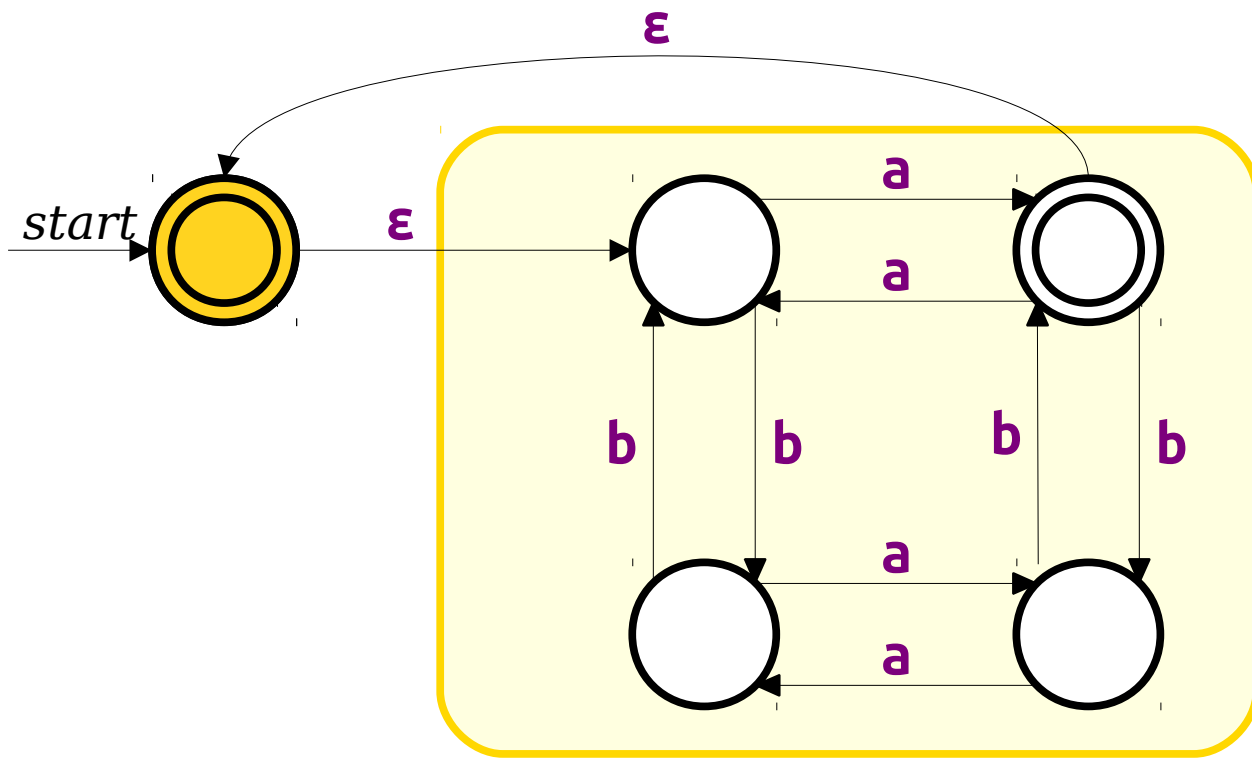

DFA for  $L$

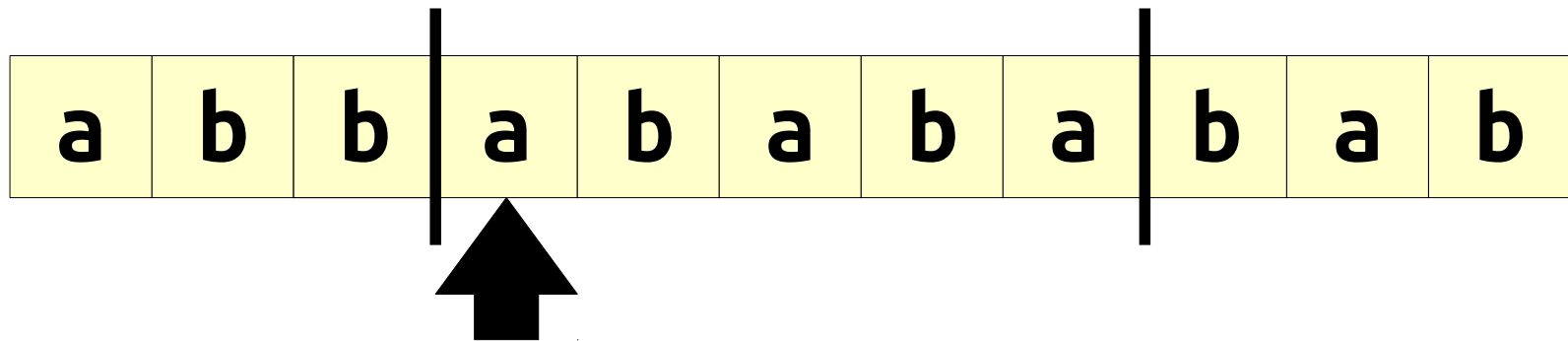

$L = \{ w \in \{a, b\}^* \mid w \text{ has an odd number of } a\text{'s and an even number of } b\text{'s} \}$

Construct an NFA for  $L^*$ .

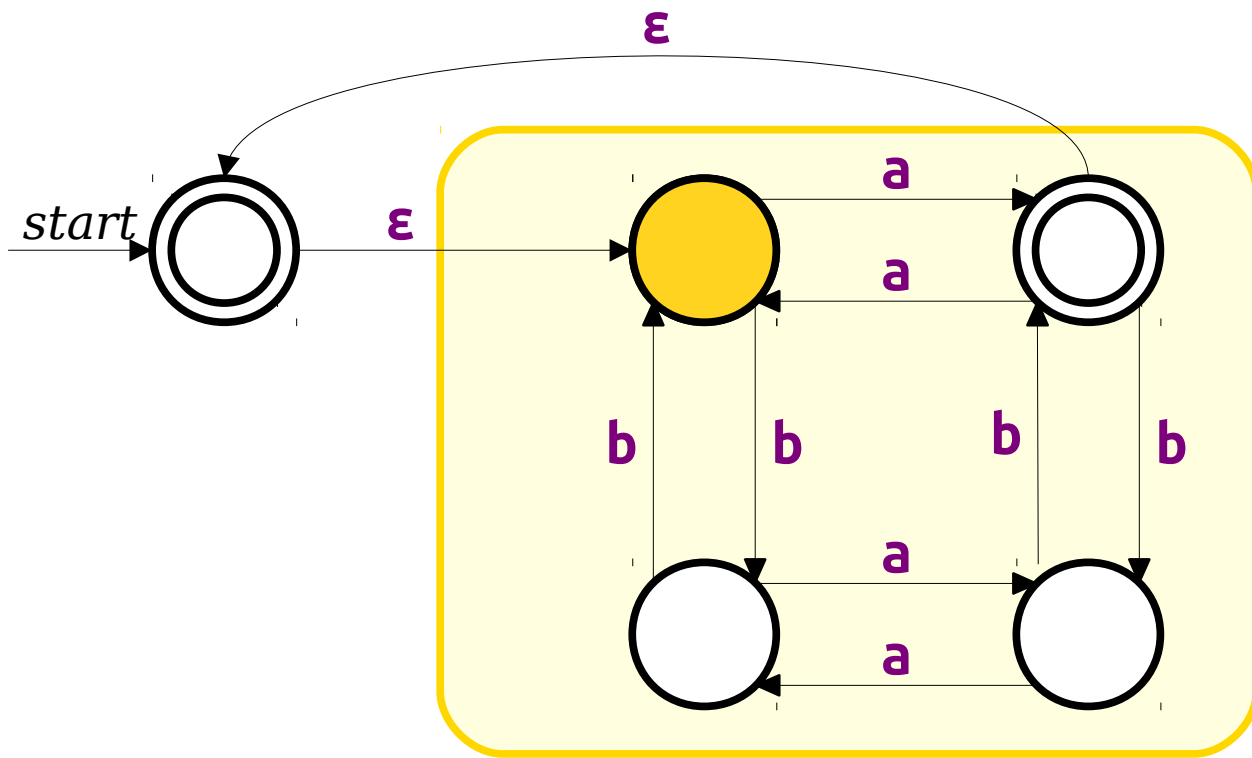

DFA for  $L$

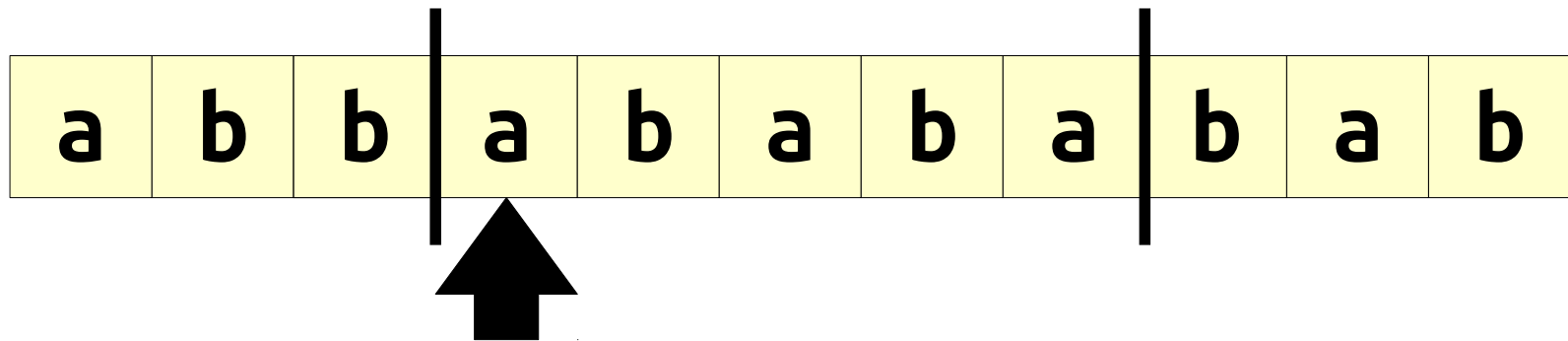

$L = \{ w \in \{a, b\}^* \mid w \text{ has an odd number of } a\text{'s and an even number of } b\text{'s} \}$

Construct an NFA for  $L^*$ .

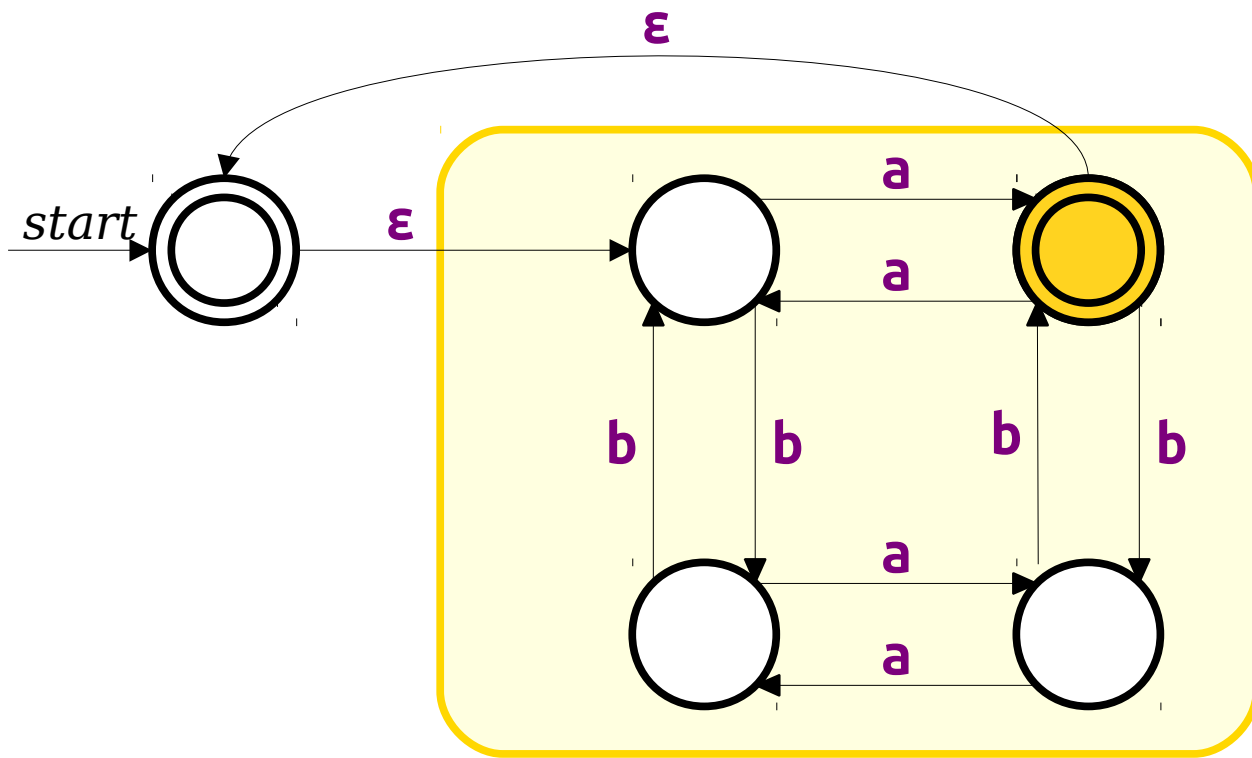

DFA for  $L$

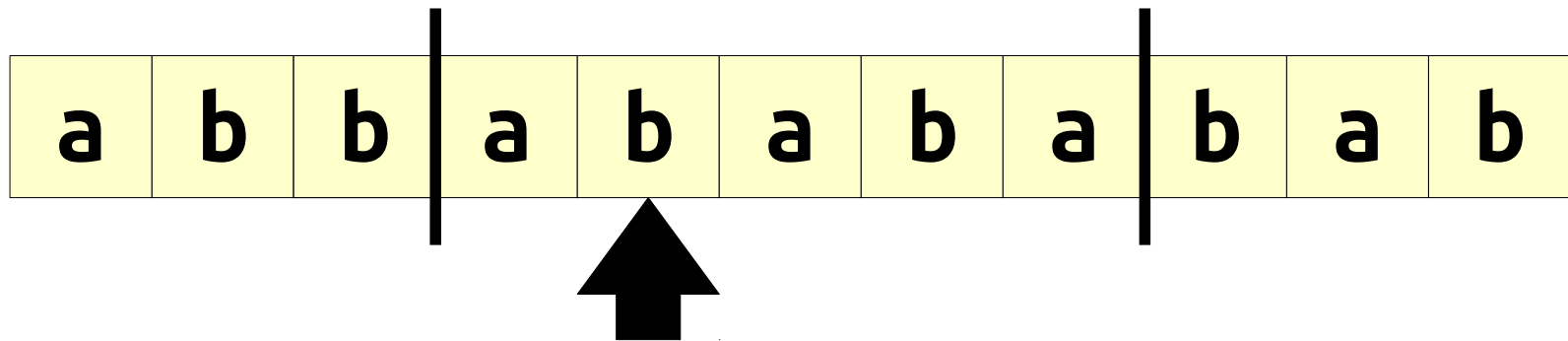

$L = \{ w \in \{a, b\}^* \mid w \text{ has an odd number of } a\text{'s and an even number of } b\text{'s} \}$

Construct an NFA for  $L^*$ .

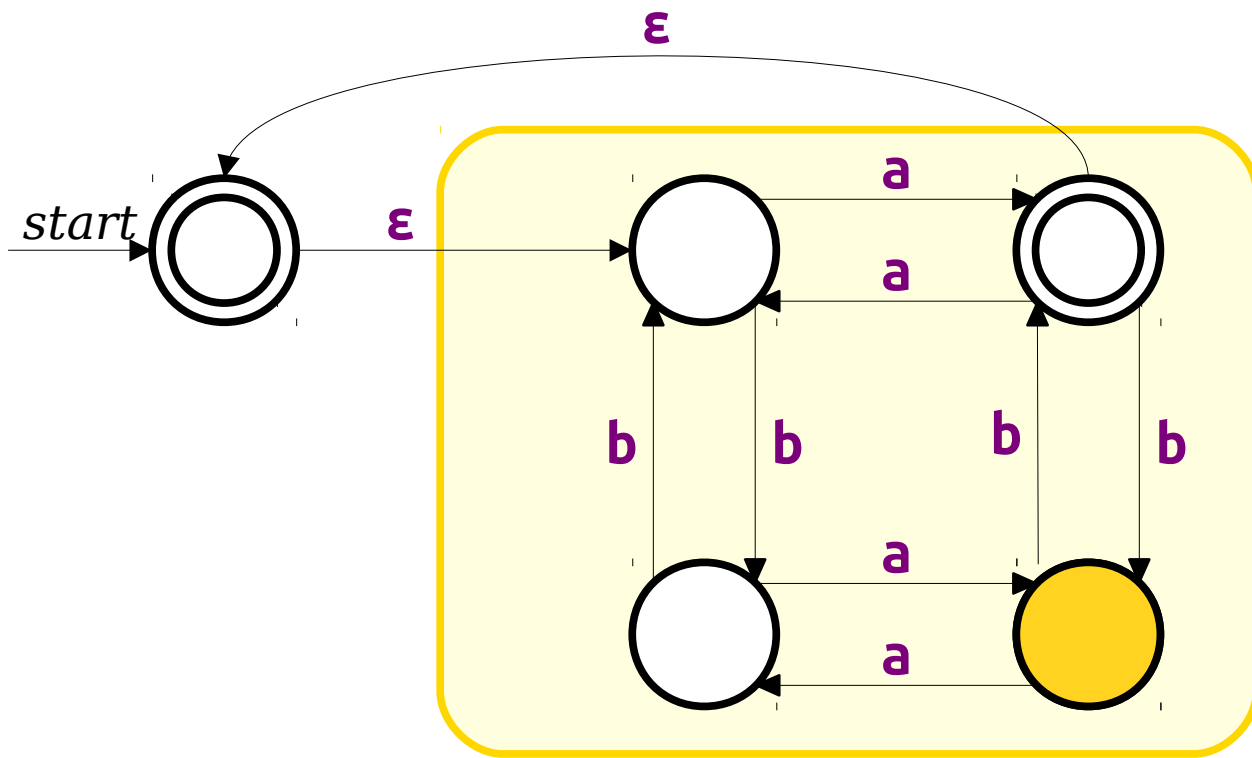

DFA for  $L$

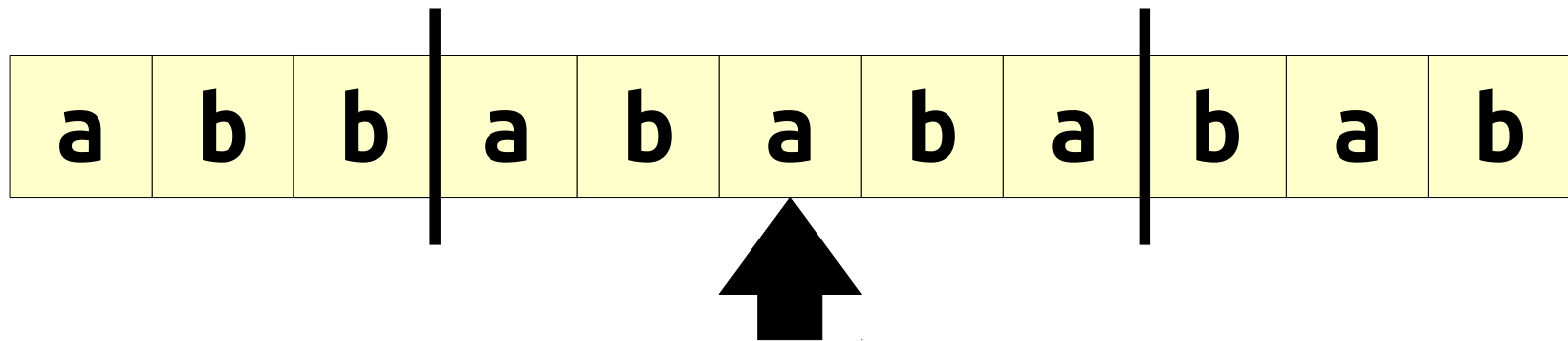

$L = \{ w \in \{a, b\}^* \mid w \text{ has an odd number of } a\text{'s and an even number of } b\text{'s} \}$

Construct an NFA for  $L^*$ .

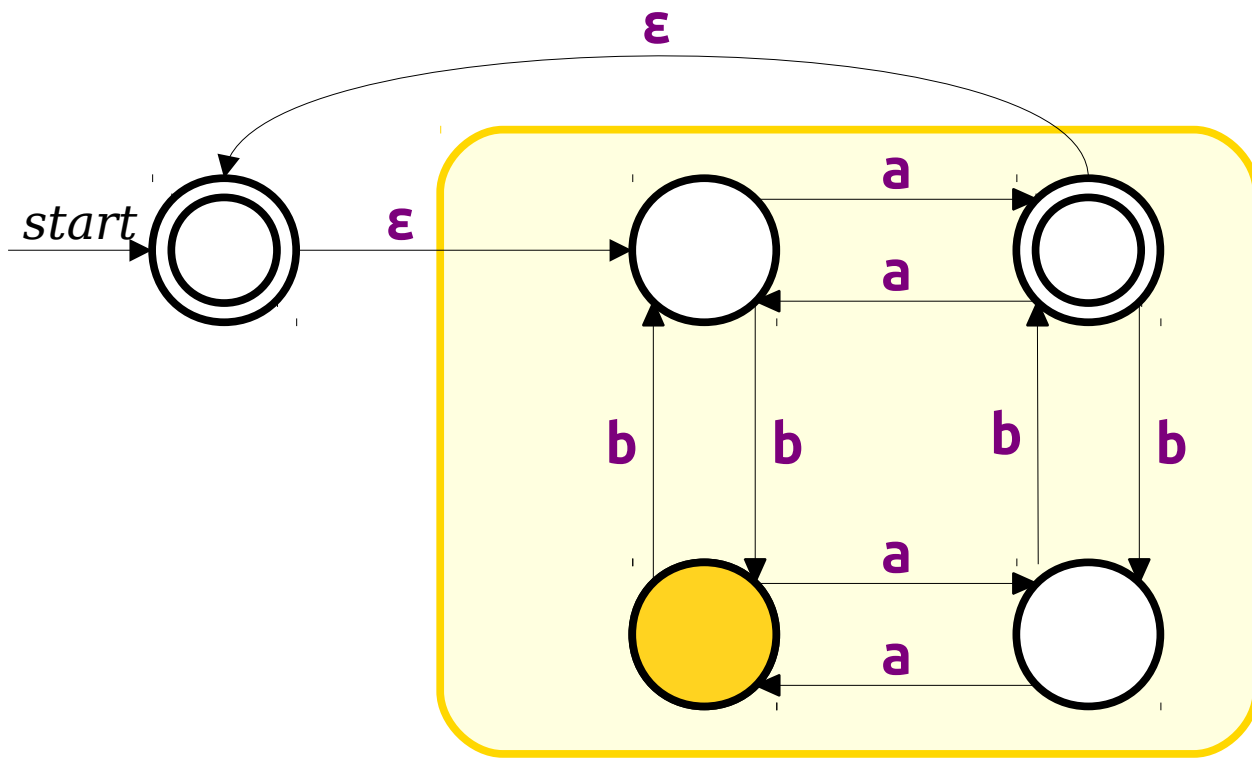

DFA for  $L$

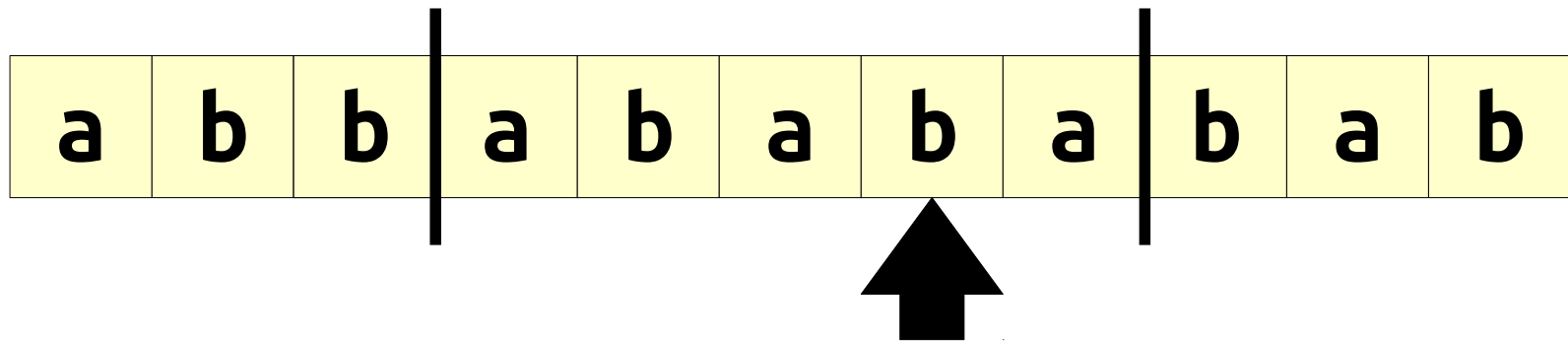

$L = \{ w \in \{a, b\}^* \mid w \text{ has an odd number of } a\text{'s and an even number of } b\text{'s} \}$

Construct an NFA for  $L^*$ .

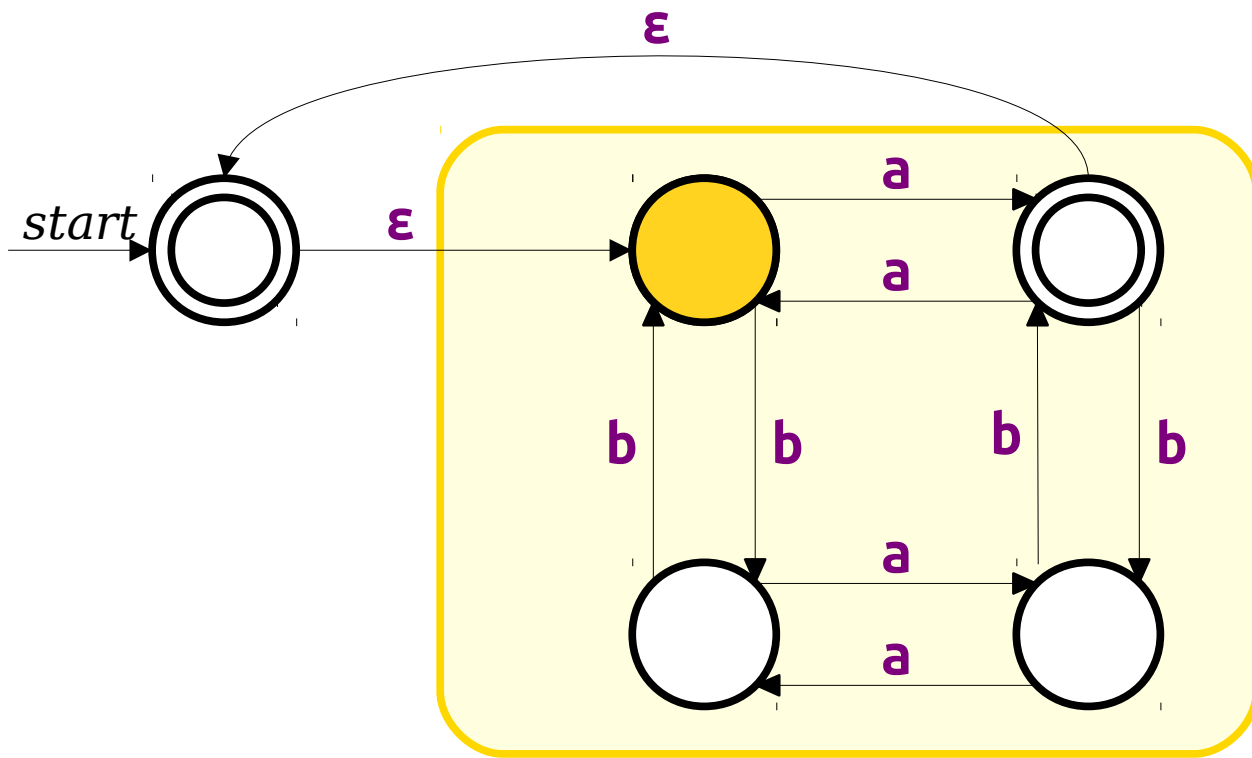

DFA for  $L$

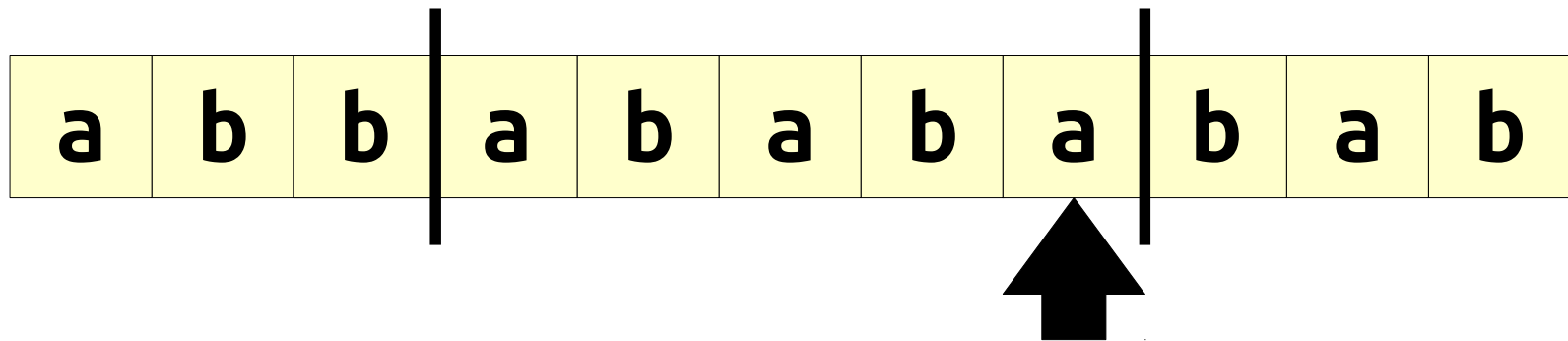

$L = \{ w \in \{a, b\}^* \mid w \text{ has an odd number of } a\text{'s and an even number of } b\text{'s} \}$

Construct an NFA for  $L^*$ .

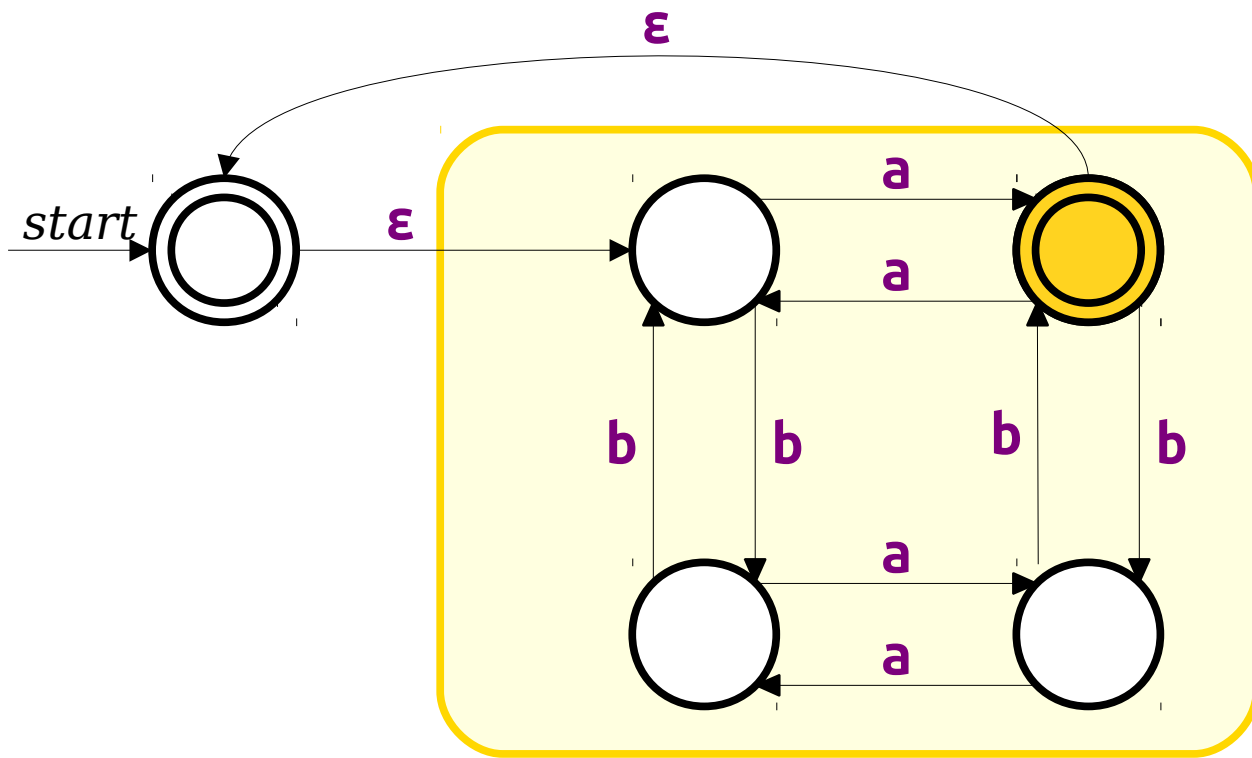

DFA for  $L$

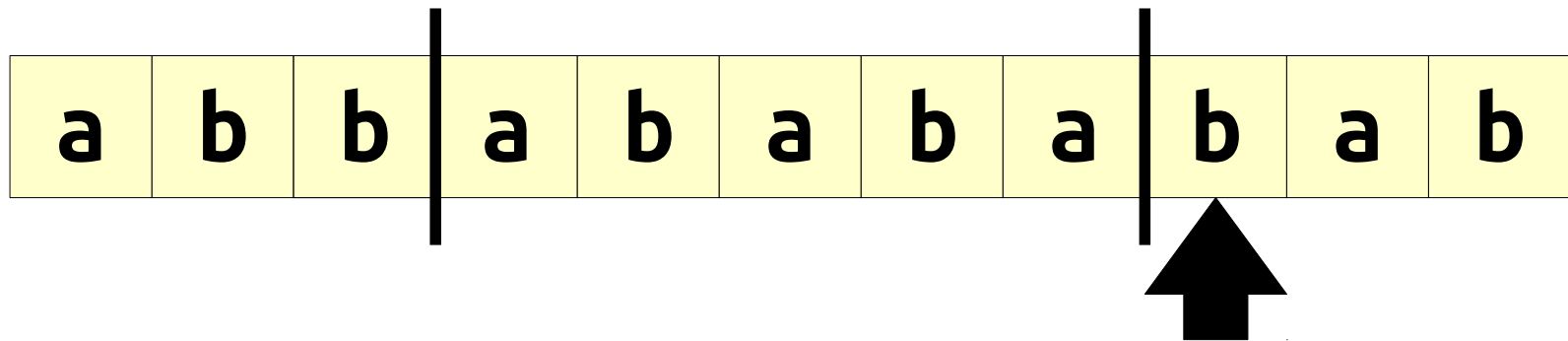

$L = \{ w \in \{a, b\}^* \mid w \text{ has an odd number of } a\text{'s and an even number of } b\text{'s} \}$

Construct an NFA for  $L^*$ .

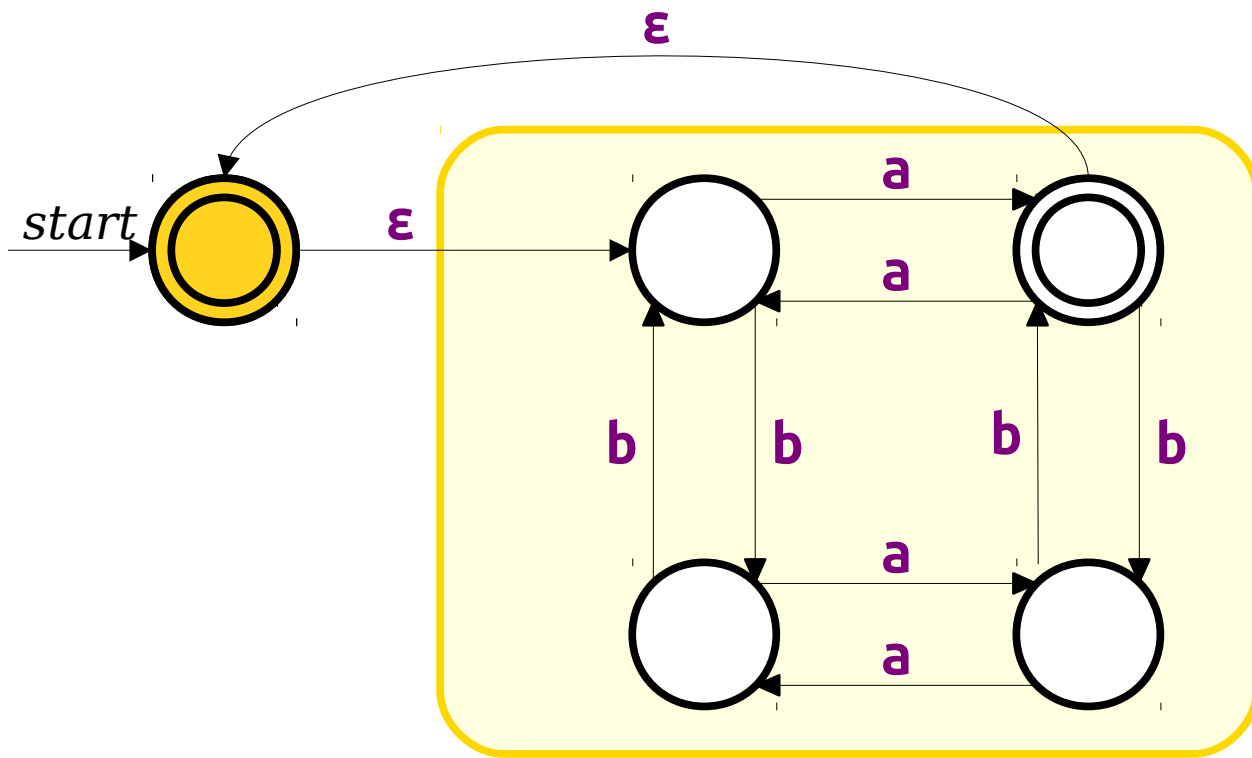

DFA for  $L$

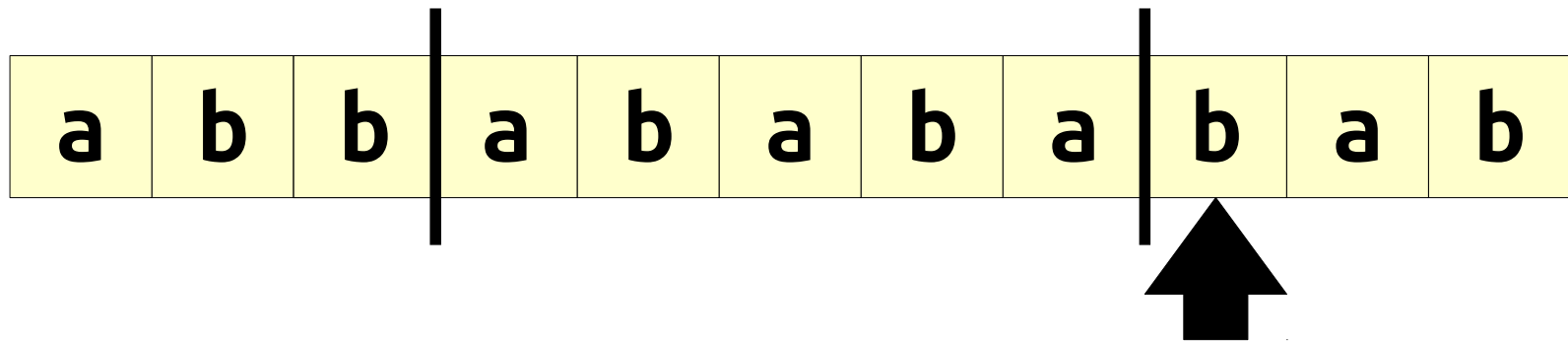

$L = \{ w \in \{a, b\}^* \mid w \text{ has an odd number of } a\text{'s and an even number of } b\text{'s} \}$

Construct an NFA for  $L^*$ .

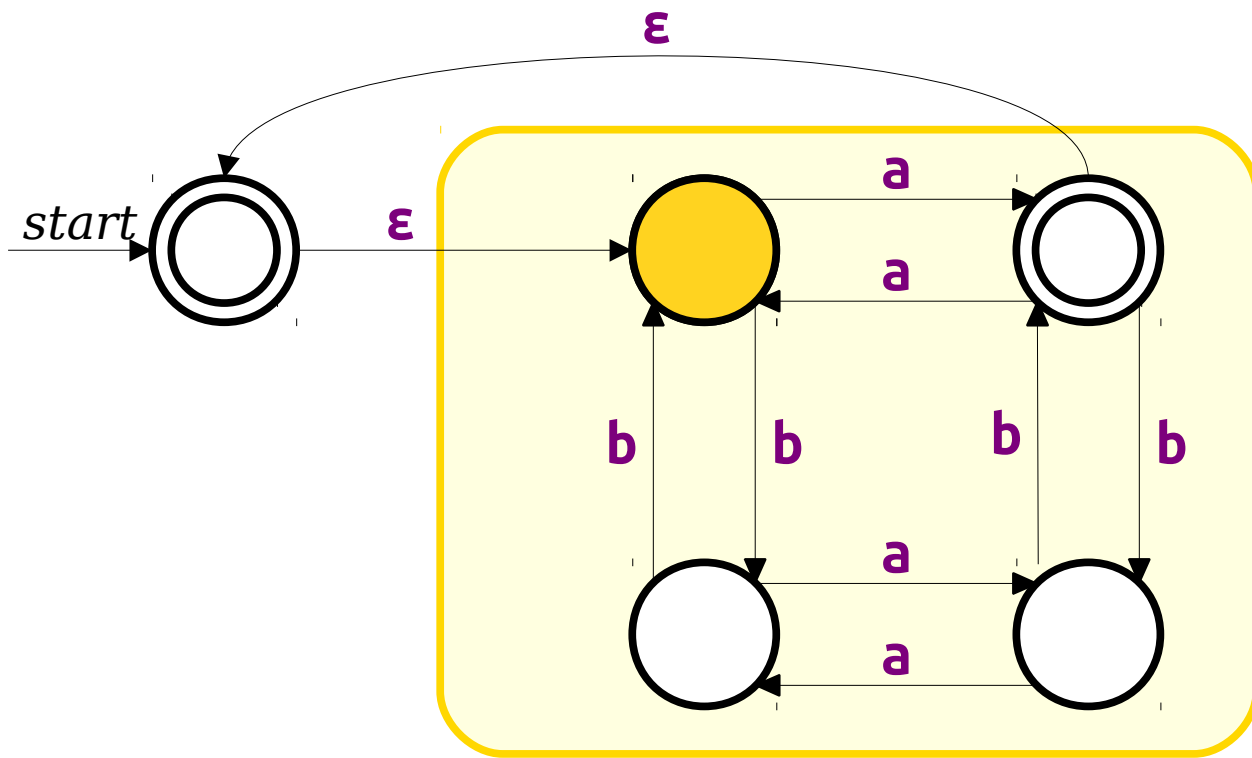

DFA for  $L$

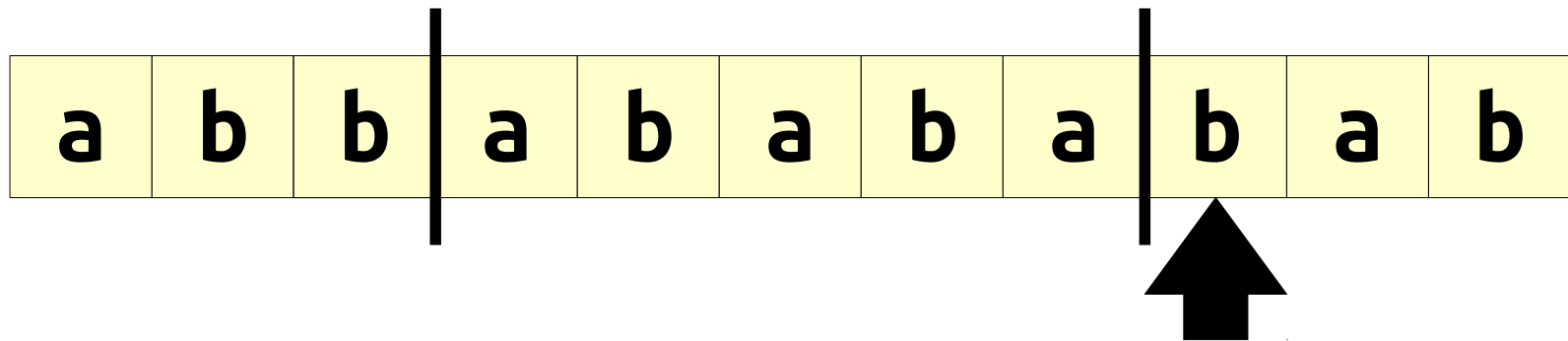

$L = \{ w \in \{a, b\}^* \mid w \text{ has an odd number of } a\text{'s and an even number of } b\text{'s} \}$

Construct an NFA for  $L^*$ .

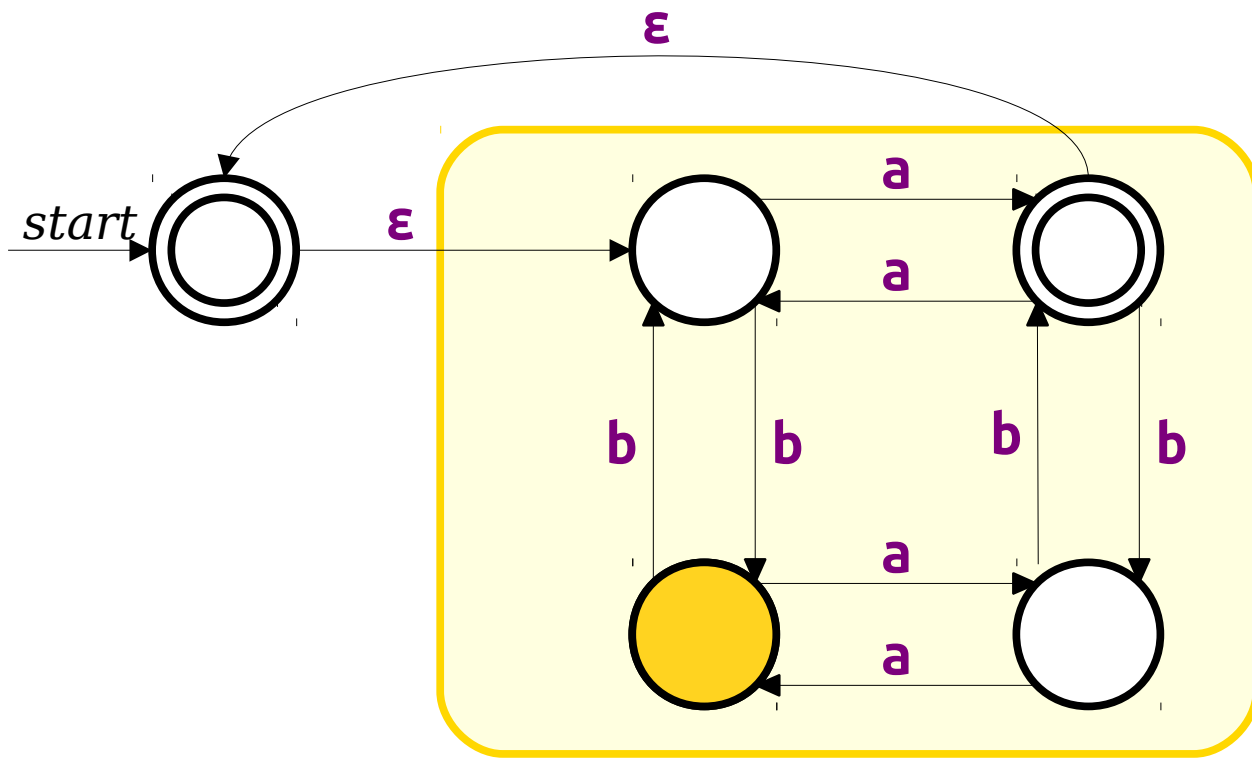

DFA for  $L$

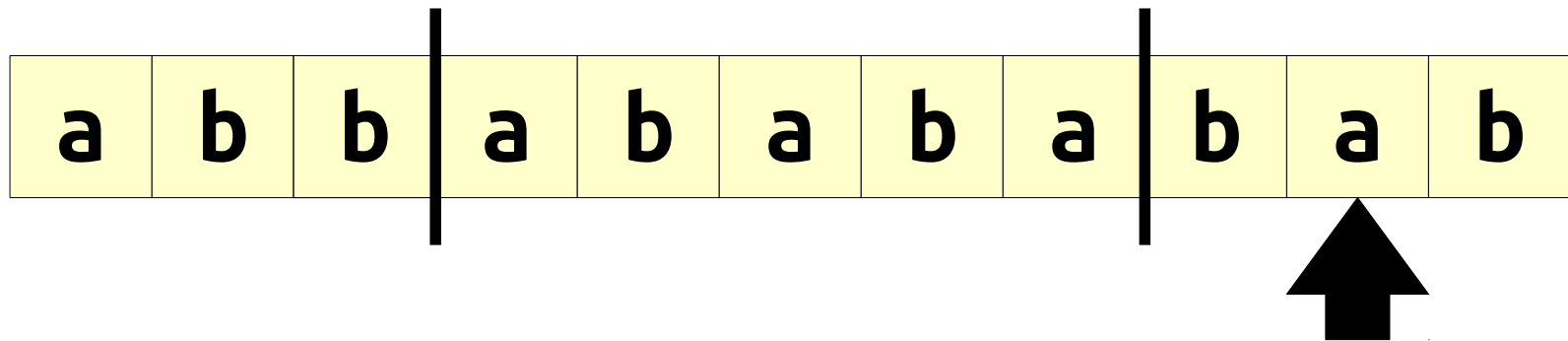

$L = \{ w \in \{a, b\}^* \mid w \text{ has an odd number of } a\text{'s and an even number of } b\text{'s} \}$

Construct an NFA for  $L^*$ .

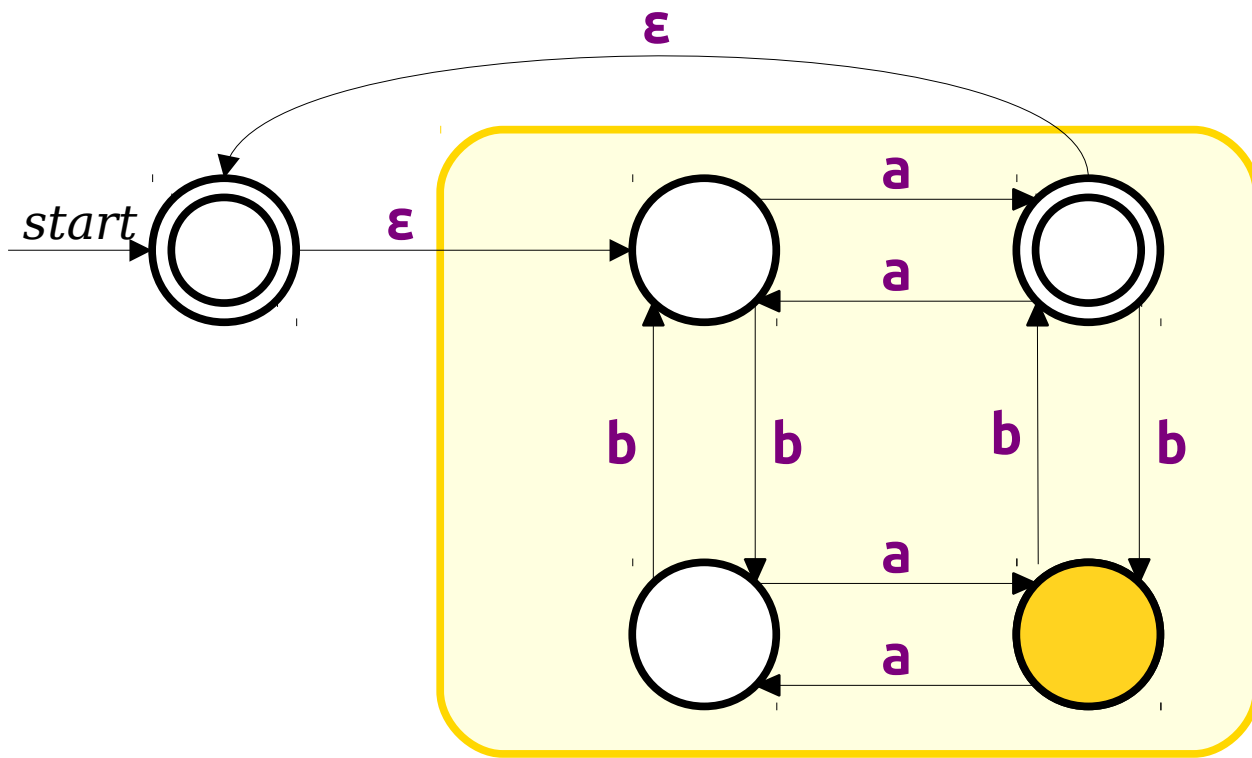

DFA for  $L$

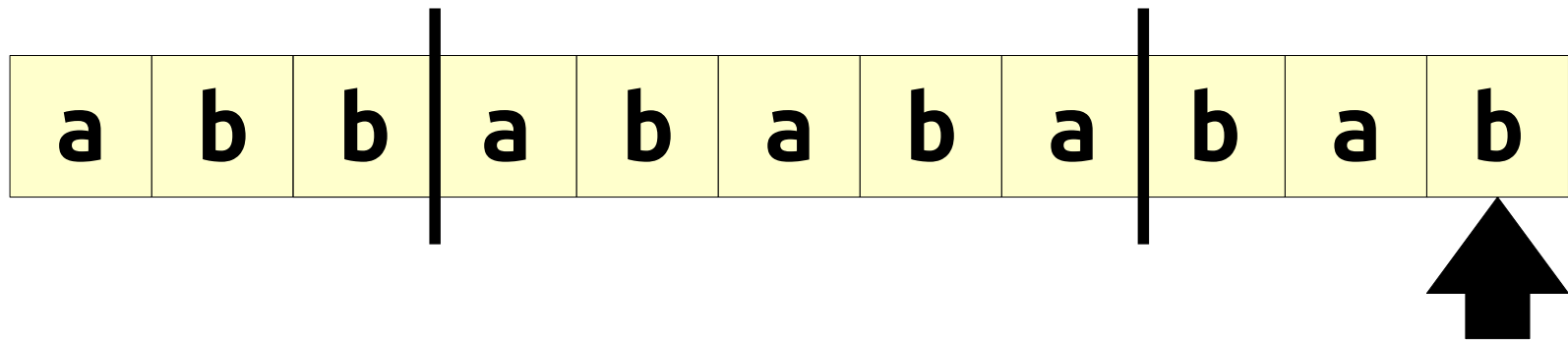

$L = \{ w \in \{a, b\}^* \mid w \text{ has an odd number of } a\text{'s and an even number of } b\text{'s} \}$

Construct an NFA for  $L^*$ .

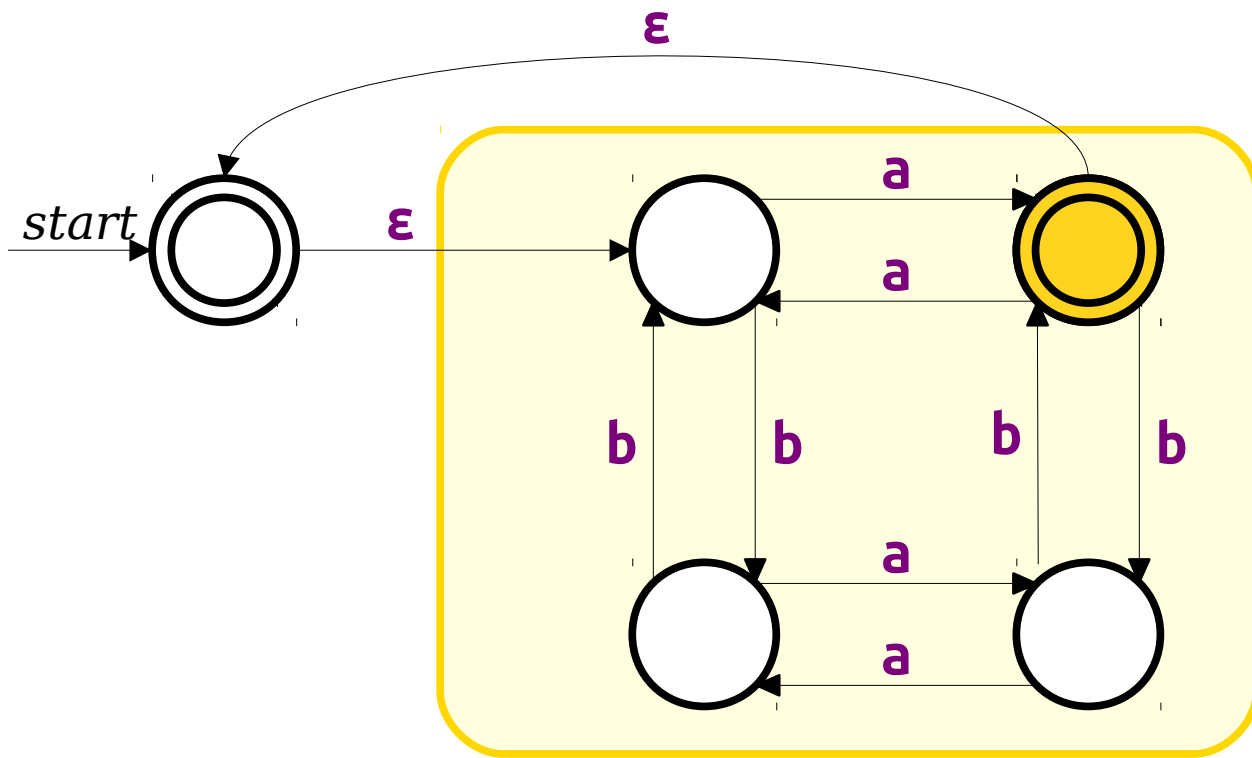

DFA for  $L$

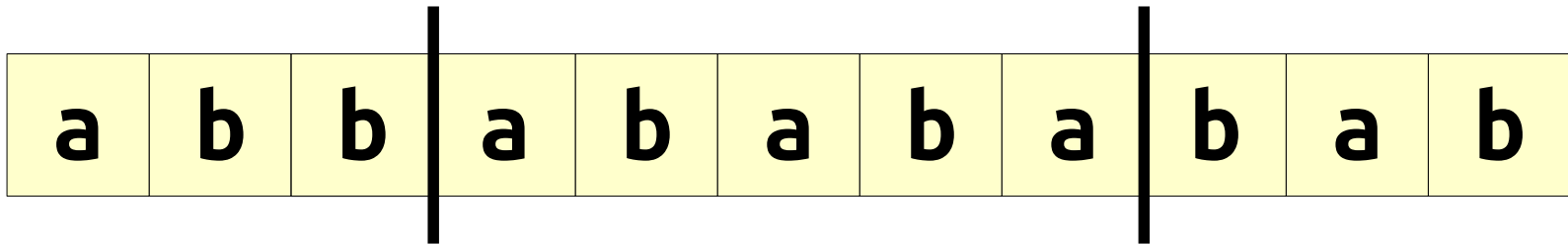

$L = \{ w \in \{a, b\}^* \mid w \text{ has an odd number of } a\text{'s and an even number of } b\text{'s} \}$

Construct an NFA for  $L^*$ .

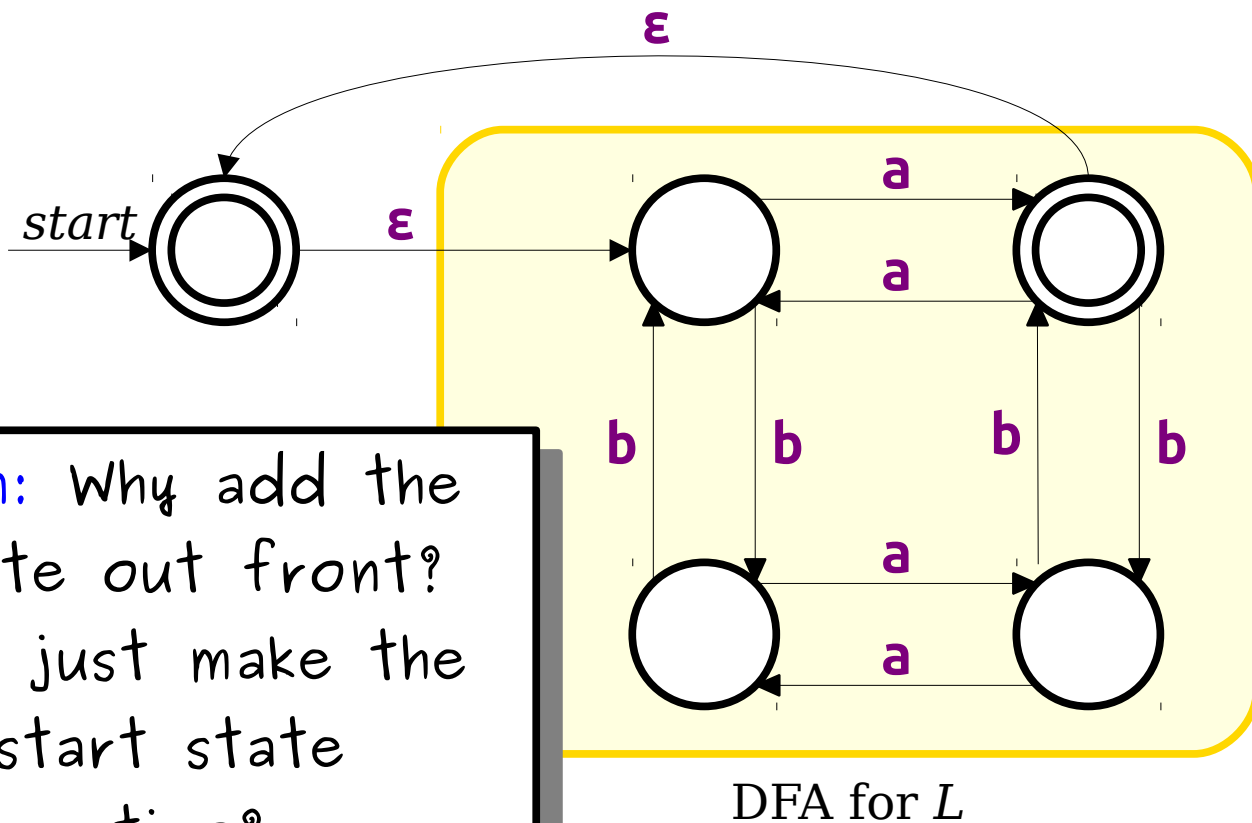

Question: Why add the new state out front?  
 Why not just make the old start state accepting?

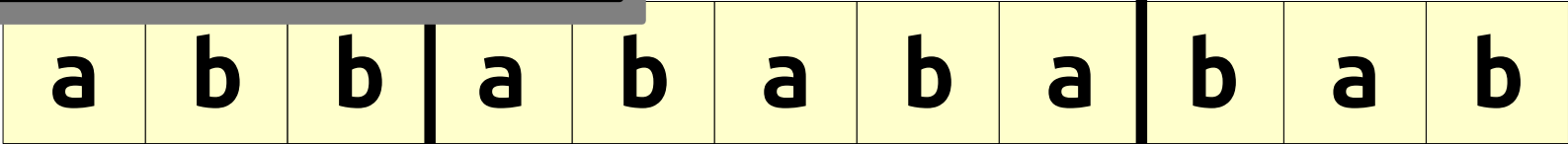

$$L = \{ w \in \{a, b\}^* \mid w \text{ has an odd number of } a\text{'s and an even number of } b\text{'s} \}$$

Construct an NFA for  $L^*$ .

# Closure Properties

- ***Theorem:*** If  $L_1$  and  $L_2$  are regular languages over an alphabet  $\Sigma$ , then so are the following languages:
  - $L_1 \cup L_2$
  - $L_1 \cap L_2$
  - $L_1L_2$
  - $L_1^*$
- These properties are called ***closure properties of the regular languages.***

# Next Time

- ***Regular Expressions***
  - Building languages from the ground up!
- ***Thompson's Algorithm***
  - A UNIX Programmer in Theoryland.
- ***Kleene's Theorem***
  - From machines to programs!